

**SECTION I - TABLE OF CONTENTS**

**Section I Contents:**

Countertop &  
 Shelf Supports/Brackets .....2-7  
 Table Hardware ..... 8  
 Table Legs ..... 9-11  
 Furniture & Cabinet Levelers ..... 12-17  
 Glides..... 18-20  
 Bumpers .....21-25  
 Casters .....26-32

A  
 B  
 C  
 D  
 E  
 F  
 G  
 H  
**I**  
 J  
 K  
 L  
 M  
 N  
 O  
 P  
 Q  
 R  
 S  
 T  
 U  
 V  
 W  
 X  
 Y



A  
B  
C  
D  
E  
F  
G  
H  
I  
J  
K  
L  
M  
N  
O  
P  
Q  
R  
S  
T  
U  
V  
W  
X  
Y

## SHELF & COUNTERTOP SUPPORTS



### EH Series Surface Mount Brackets

**Rakks®**

- Rakks Counter Support Brackets keep work areas open and accessible
- They provide heavy duty support for counters up to 30" deep while improving the handicapped accessibility and ergonomics of the work area
- Rakks counter support brackets are manufactured from easy-to-recycle structural aluminum
- Sold by the each

	Item #	Size	Counter Depth	Weight Capacity	Finish
Surface Mount 12" x 9"	RKKEH-1209	12" x 9"	13"	650 lb per bracket	Mill
	RKKEH-1209-A	12" x 9"	13"	650 lb per bracket	Almond
	RKKEH-1209-B	12" x 9"	13"	650 lb per bracket	Black
	RKKEH-1209-W	12" x 9"	13"	650 lb per bracket	Off-White/Primed
Surface Mount 12" x 12"	RKKEH-1212	12" x 12"	18"	650 lb per bracket	Mill
	RKKEH-1212-A	12" x 12"	18"	650 lb per bracket	Almond
	RKKEH-1212-B	12" x 12"	18"	650 lb per bracket	Black
	RKKEH-1212-W	12" x 12"	18"	650 lb per bracket	Off-White/Primed
Surface Mount 18" x 18"	RKKEH-1818	18" x 18"	24"	450 lb per bracket	Mill
	RKKEH-1818-A	18" x 18"	24"	450 lb per bracket	Clear Ano
	RKKEH-1818-B	18" x 18"	24"	450 lb per bracket	Black
	RKKEH-1818-W	18" x 18"	24"	450 lb per bracket	Off-White/Primed
Surface Mount 18" x 24"	RKKEH-1824	18" x 24"	30"	450 lb per bracket	Mill
	RKKEH-1824-A	18" x 24"	30"	450 lb per bracket	Clear Ano
	RKKEH-1824-B	18" x 24"	30"	450 lb per bracket	Black
	RKKEH-1824-W	18" x 24"	30"	450 lb per bracket	Off-White/Primed
Flush Mount 12" x 9"	RKKEH-1209FM	12" x 9"	13"	430 lb per bracket	Mill
	RKKEH-1209FM-B	12" x 9"	13"	430 lb per bracket	Black
	RKKEH-1209FM-W	12" x 9"	13"	430 lb per bracket	Off-White/Primed
Flush Mount 12" x 12"	RKKEH-1212FM	12" x 12"	18"	430 lb per bracket	Mill
	RKKEH-1212FM-A	12" x 12"	18"	430 lb per bracket	Clear Ano
	RKKEH-1212FM-B	12" x 12"	18"	430 lb per bracket	Black
	RKKEH-1212FM-W	12" x 12"	18"	430 lb per bracket	Off-White/Primed
Flush Mount 18" x 18"	RKKEH-1818FM	18" x 18"	24"	300 lb per bracket	Mill
	RKKEH-1818FM-A	18" x 18"	24"	300 lb per bracket	Clear Ano
	RKKEH-1818FM-B	18" x 18"	24"	300 lb per bracket	Black
	RKKEH-1818FM-W	18" x 18"	24"	300 lb per bracket	Off-White/Primed
Flush Mount 18" x 24"	RKKEH-1824FM	18" x 24"	30"	300 lb per bracket	Mill
	RKKEH-1824FM-A	18" x 24"	30"	300 lb per bracket	Clear Ano
	RKKEH-1824FM-B	18" x 24"	30"	300 lb per bracket	Black
	RKKEH-1824FM-W	18" x 24"	30"	300 lb per bracket	Off-White/Primed

**SHELF & COUNTERTOP SUPPORTS**

A  
B  
C  
D  
E  
F  
G  
H  
I  
J  
K  
L  
M  
N  
O  
P  
Q  
R  
S  
T  
U  
V  
W  
X  
Y

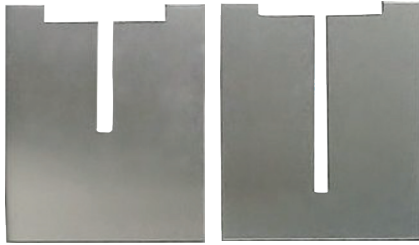

**Inside Wall Counter Support Face Plate**

**Rakks®**

- Designed to work with Rakks EH-1818, EH-1824, EH-1212 and EH-1209 Flush-Mount Counter Supports
- Adhesive backed plate fits over the supporting arm of the bracket and eliminates the need to patch and fill the drywall
- Sold by the each

Item #	Size	Finish	Use With
RKKEH-FP22	2" x 2" x 1/4"	Aluminum	EH-1818, EH-1212 and EH-1209 Flush Mount Supports
RKKEH-FP23	2" x 3" x 3/16"	Aluminum	EH-1824 Flush Mount Supports

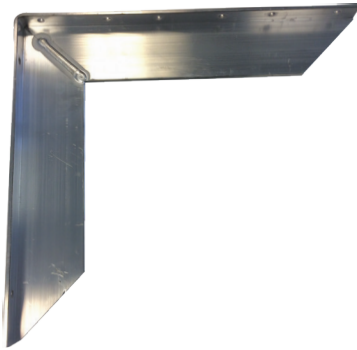

**EH B Series Surface Mount Bench Support Bracket**

**Rakks®**

- Used for seating applications incorporating 5" wooden planking
- The supporting arm is pre-drilled with 12 holes to provide secure installation
- Manufactured from 2" x 3" "T" to provide maximum stiffness
- Sold by the each

Item #	Weight Capacity	Size	Finish
RKKEH-1416B	450 lb per bracket	14-3/4" x 15-3/4"	Mill



**FB Sill Support Bracket**

**Rakks®**

- Manufactured from structural aluminum angle
- These brackets can be used anywhere low profile support or bracing is required
- Sold by the each

Item #	Weight Capacity	Size	Finish
RKKFB-0406	150 lb per bracket	4" D x 6" H	Mill



**EH Series Vanity Brackets**

**Rakks®**

- ADA compliant aluminum vanity brackets simplify and reduce the cost of installing sinks and provide a stable and sturdy mounting surface for custom-built enclosures
- Vanity Brackets are supplied with wooden strips on the front faces to provide for the convenient mounting, or removal, of laminated or solid surface panels
- Sold by the each

Item #	Weight Capacity	Size	Finish
RKKEH-1818-LV	450 lb. per Bracket	18" x 21-1/2"	Mill

**A WORKSTATION BRACKETS**



**Shelf & Countertop Supports  
Rigid, Heavy Duty**



- Load rating 1,000 lbs. per pair
  - 1/8" steel
  - Multiple 1/4" mounting hole locations (mounting hardware not included)
  - For use in workbenches, workstations, garage storage, ADA stations, computer stations, etc.
  - Reversible design makes brackets versatile and easy to use
  - Packaged in equal quantities of "rights" and "lefts"
  - The six larger sizes have a 3" x 3" - 45° notch that allows for wall cleat and wire run clearance
- Packing and sold in: As shown below. Available in any quantity of pairs.

Almond Item #	Black Item #	Gray Item #	Primed Item #	Stainless Steel Item #	White Item #	Box Qty
<b>5" Shelf Length x 8" Wall Length</b>						
PROWSB05X08-AL	PROWSB05X08-BL	PROWSB05X08-GR	-	-	PROWSB05X08-WH	5 Pair
<b>8" Shelf Length x 12" Wall Length</b>						
PROWSB08X12-AL	PROWSB08X12-BL	PROWSB08X12-GR	-	-	PROWSB08X12-WH	5 Pair
<b>12" Shelf Length x 18" Wall Length</b>						
-	PROWSB12X18-BL	PROWSB12X18-GR	-	-	PROWSB12X18-WH	3 Pair
<b>15" Shelf Length x 21" Wall Length</b>						
PROWSB15X21-AL	PROWSB15X21-BL	PROWSB15X21-GR	PROWSB15X21-PR	PROWSB15X21-SS	PROWSB15X21-WH	3 Pair
<b>18" Shelf Length x 18" Wall Length</b>						
PROWSB18X18-AL	PROWSB18X18-BL	PROWSB18X18-GR	PROWSB18X18-PR	-	PROWSB18X18-WH	3 Pair
<b>18" Shelf Length x 24" Wall Length</b>						
PROWSB18X24-AL	PROWSB18X24-BL	PROWSB18X24-GR	PROWSB18X24-PR	-	PROWSB18X24-WH	3 Pair
<b>24" Shelf Length x 24" Wall Length</b>						
PROWSB24X24-AL	PROWSB24X24-BL	PROWSB24X24-GR	-	-	PROWSB24X24-WH	3 Pair
<b>24" Shelf Length x 29" Wall Length</b>						
PROWSB24X29-AL	PROWSB24X29-BL	PROWSB24X29-GR	-	-	PROWSB24X29-WH	2 Pair

## SHELF & COUNTERTOP SUPPORTS

### Speed Brace, Heavy Duty Brackets



- 1-1/2" x 1-1/2" notching system for quick alignment/installation (3/4" x 1-1/2" on FCSB5X8 Series)
- Cable management holes
- Countersunk screw holes
- Fasteners not included (FCSB-ANCHOR, pack of 10)
- Sold by the each

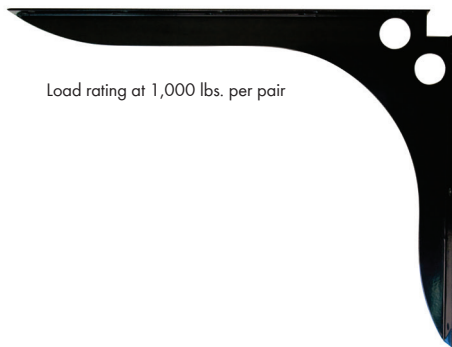

Black Item #	Primed Item #	Stainless Steel Item #	White Item #
<b>5" Shelf Length x 8" Wall Length</b>			
FCSB5X8-BL	-	-	FCSB5X8-WH
<b>8" Shelf Length x 12" Wall Length</b>			
FCSB8X12-BL	FCSB8X12-PRIME	FCSB8X12-SS	FCSB8X12-WH
<b>15" Shelf Length x 18" Wall Length</b>			
FCSB15X18-BL	FCSB15X18-PR	FCSB15X18-SS	FCSB15X18-WH
<b>21" Shelf Length x 24" Wall Length</b>			
FCSB21X24-BL	FCSB21X24-PR	FCSB21X24-SS	FCSB21X24-WH
<b>21" Shelf Length x 28" Wall Length</b>			
FCSB21X27-BL	FCSB21X28-PR	FCSB21X27-SS	FCSB21X27-WH

### Concealed Brackets Without Upper Extension



- 1/4" steel
- Includes mounting hardware 3/8" x 4" carriage bolts, hex nuts and flat washers
- Mounts directly to wall studs
- Load limit over 1,000 lbs. per pair
- All welds on reverse for easy, clean install
- Sold by the each



Item #	Depth	Overall Height	Color
<b>9" Support Arm Length</b>			
PROWCB-09AL	9"	12"	Almond
PROWCB-09BL	9"	12"	Black
PROWCB-09GR	9"	12"	Gray
PROWCB-09WH	9"	12"	White
<b>12" Support Arm Length</b>			
PROWCB-12AL	12"	12"	Almond
PROWCB-12BL	12"	12"	Black
PROWCB-12GR	12"	12"	Gray
PROWCB-12WH	12"	12"	White
<b>18" Support Arm Length</b>			
PROWCB-18AL	18"	18"	Almond
PROWCB-18BL	18"	18"	Black
PROWCB-18GR	18"	18"	Gray
PROWCB-18WH	18"	18"	White
<b>24" Support Arm Length</b>			
PROWCB-24AL	24"	18"	Almond
PROWCB-24BL	24"	18"	Black
PROWCB-24GR	24"	18"	Gray
PROWCB-24WH	24"	18"	White

A  
B  
C  
D  
E  
F  
G  
H  
I  
J  
K  
L  
M  
N  
O  
P  
Q  
R  
S  
T  
U  
V  
W  
X  
Y

A  
B  
C  
D  
E  
F  
G  
H  
I  
J  
K  
L  
M  
N  
O  
P  
Q  
R  
S  
T  
U  
V  
W  
X  
Y

## SHELF & COUNTERTOP SUPPORTS

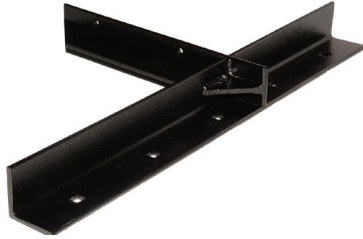

### Concealed Brackets With Upper Extension



- 1/4" steel
- Includes mounting hardware 3/8" x 4" carriage bolts, hex nuts and flat washers
- Mounts directly to wall studs
- Load limit over 1,000 lbs. per pair
- All welds on reverse for easy, clean install
- Sold by the each in multiples of 2

Item #	Depth	Overall Height	Color	Box Qty
<b>9" Support Arm Length</b>				
PROWCBE-09BL	9"	20"	Black	2 Each
PROWCBE-09WH	9"	20"	White	2 Each
<b>12" Support Arm Length</b>				
PROWCBE-12BL	12"	20"	Black	2 Each
PROWCBE-12WH	12"	20"	White	2 Each
<b>18" Support Arm Length</b>				
PROWCBE-18BL	18"	26"	Black	2 Each
PROWCBE-18WH	18"	26"	White	2 Each
<b>24" Support Arm Length</b>				
PROWCBE-24BL	24"	26"	Black	2 Each
PROWCBE-24WH	24"	26"	White	2 Each



### Stealth Brace



- Support countertop and bar overhangs with no visible kicker or corbels
- Each brace will support 200 pounds of weight
- 1/4" steel is powder-coated
- Countersunk screwholes
- Simply route a 3-1/2" slot in the substrate and mount
- Sold by the each

Size	Weight Capacity	Black Item #	Prime Item #	White Item #
<b>Standard Duty</b>				
3-1/2" x 12" x 3/16"	300 lb per pair	FCSTEALTH	-	FCSTEALTH-WHITE
3-1/2" x 16" x 3/16"	300 lb per pair	FCSBSTEALTH-16BL	FCSBSTEALTH-16PR	-
3-1/2" x 24" x 3/16"	300 lb per pair	FCSBSTEALTH-24BL	FCSBSTEALTH-24PR	-
3-1/2" x 30" x 3/16"	300 lb per pair	FCSTEALTH-30BL	FCSTEALTH-30PRIMED	-
<b>Heavy Duty</b>				
3-1/2" x 12" x 1/4"	500 lb per pair	FCSBSTEALTHHD-12BL	FCSBSTEALTHHD-12PR	-
3-1/2" x 16" x 3/8"	500 lb per pair	FCSBSTEALTHHD-16BL	-	-
3-1/2" x 24" x 3/8"	500 lb per pair	FCSBSTEALTHHD-24BL	-	-
3-1/2" x 30" x 3/8"	500 lb per pair	FCSBSTEALTHHD-30BL	-	-

## FLOATING BRACKETS



For dimensional line drawing, see our website.

### Floating Vanity Brackets



- Innovative floating shelf brackets post sheetrock installation eliminates the need to patch and repaint sheet rock
- "U" shaped design allows for easy install after sheetrock with only a 2" x 2" hole
- Front holes at top and bottom allow for easy install and leveling
- 3/4" tube steel bars welded to "U" bracket to allow plenty of support for heavy items
- 3/4" tube allows for extra weight of floating vanity to be easily supported even with heavy granite or concrete counter tops
- Support bar can be cut to length as needed
- Accessory kit available, includes 1 Wall Cover, 1 End Cap, and 1 Mid Clip
- Patent Pending
- Sold by the each

Item #	Description	Weight Capacity
SHBFS-20	20" Floating Vanity Bracket	200 lb
SHBFS-20KIT-BL	Vanity Access Kit, Black	-
SHBFS-20KIT-WH	Vanity Access Kit, White	-

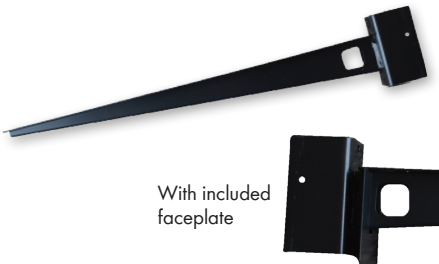

For dimensional line drawing, see our website.

### Concealed Floating Countertop Brackets



- Perfect for any floating countertops
- From laminate to granite and everything in between, these brackets are easy to install and stay out of your way
- Wire management hole
- Faceplate included for a finished look
- Patent Pending
- Sold by the each

Item #	Description	Weight Capacity
SHBCT-18BL	18" Bracket, Black	350 lb
SHBCT-18WH	18" Bracket, White	350 lb
SHBCT-22BL	22" Bracket, Black	350 lb
SHBCT-22WH	22" Bracket, White	350 lb



### Speed Brace, T Brace



- The SpeedBrace T-Brace is the perfect way to create the illusion of free-floating shelves
- Strong enough to support over 300 lbs per pair (sold by each)
- Ideal for new construction but can be used in a remodeling application when an access hole is cut into the drywall for attachment
- Reversible - mounting holes on both sides
- Sold by the each

Item #	Finish	Leg Length	Overall Length	Thickness
FCSB11-TBRACE-BL	Black	11"	12-1/2"	3/4"
FCSB16-TBRACE-BL	Black	16"	17-1/2"	3/4"

**A TABLE HARDWARE**



**Aluminum Folding Bracket**

- Drop leaf support is constructed from aluminum
- Automatically locks when flap is in open position
- Has release lever for unlocking
- For panel thickness 19/32"- 1-3/8"
- Max. Width for 1 drop leaf support is 23-5/8"
- Max. Width for 2 drop leaf supports is 51-3/16"
- Aluminum Material with an Anodized Aluminum Finish
- Installation screws not included



Item #	Closed Dimensions	Extended Length	Weight Capacity	Sold In
SG38820-25	3-1/32"W x 1-31/32"H x 4-31/64"L	7-3/32"L	77 lbs	Per Each
SG38830-25	3-1/32"W x 1-31/32"H x 6-5/8"L	10-7/8"L	121 lbs	Per Each
SG38845-25	3-1/32"W x 1-31/32"H x 10-1/8"L	16-31/32"L	132 lbs	Per Each
SG38860-25	3-1/32"W x 1-31/32"H x 14-1/2"L	23-1/16"L	176 lbs	Per Each

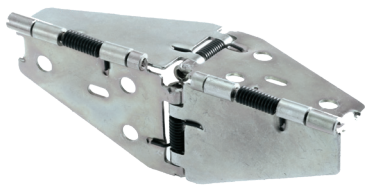

**Drop-Leaf Hinges, Heavy Duty**

- Table flaps are held securely under the table top
- The leaves open 180° and automatically lock into position
- Converts small rectangular tables to larger circular tables or to add length to oblong tops
- Installation screws are included



Item #	Steel Gauge	Finish	Sold In
SYH899P	Heavy DutySteel, .098 Gauge	Brass Plated	8/Set

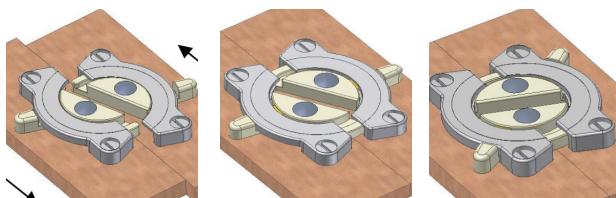

**Table Apron Leg Brackets**

- Heavy gauge steel brackets to hold together the four corners of the table apron and provide a means of fastening the leg to the bracket
- A hanger screw is driven into the leg and locked into place through the bracket with a wing nut
- Screws not included



Item #	Size	Sold In
SYS3620U	1-1/2"W x 3"L	Per Each
SYS3622U	2"W x 4-3/4"L	Per Each



Attach one half of connector to each tabletop

Twist...

And lock into place!

**Table Clamps**

- Peter Meier's Conny Connector
- Innovative way to firmly link table tops together
- Clamp is made up of two pieces (see images to the left)
- Screws not included



Item #	Dimension	Material	Finish	Sold In
PT812-02-NY	3-1/2" Dia.	Steel	Zinc	Per Each



## FOLDING TABLE LEGS

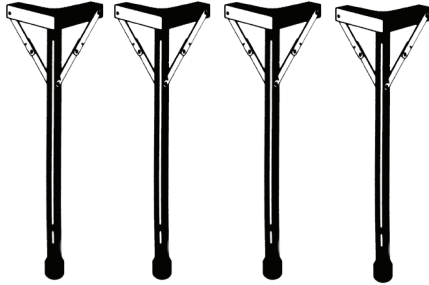

### Game Table Design Table Leg, Black



- Used to create picnic tables, display tables, card tables, ping-pong tables, and casino tables
- Easy to fold: includes screws and plastic floor protectors
- Table top minimum of 36" square for the legs to fold correctly underneath the table
- Leg is made of 1" diameter steel tubing, 29" leg height
- Set includes: 4 legs complete with mounting hardware including screws and protective caps

Item #	Color
EBFLS4	Black

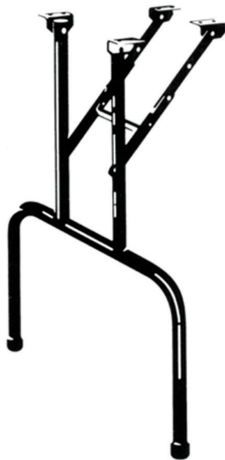

### Banquet Table Design Table Legs



- Multi-purpose steel legs for making all sorts of folding tables
- Locking device made from heavy gauge steel
- Legs are 1" tubular steel
- Tightly welded joints and protective plastic tips
- Available in two finishes: Black and Chrome
- Includes: 2 legs per set, complete with nuts, bolts and protective tips

Item #	Finish	Height	Base Width
EBCAPF-BLK	Black	29"	24"
EBCPF-CHR	Chrome	29"	24"



### Folding Leg Brackets, Surface Mount



- For lightweight table legs, with a maximum table leg width of 1-1/2"
- Steel unit has positive locking in open and closed positions with thumb pressure release
- Sold without screws

Item #	Size	Finish
SYS149L	2-1/2 L" x 2-1/2"L	Dark Copper

**A STEEL TABLE LEGS**

B  
C  
D  
E  
F  
G  
H  
I  
J  
K  
L  
M  
N  
O  
P  
Q  
R  
S  
T  
U  
V  
W  
X  
Y



**Hamburg Series  
Steel Table Legs, 2-3/8" Diameter**



- Load bearing capacity of 660 lbs. per leg
- 2-3/8" diameter, 27-3/4" L (table height), 28-7/8" L full extension
- All legs come with separate brackets to attach the leg to the table and all necessary screws
- Legs have 1-1/8" adjustment built in feet
- Single packs include: (1) leg, (1) bracket and screws
- Four leg packs include: (4) legs, (4) brackets and screws

Finish	Single Pack Item #	Four Pack Item #
Flat Black	PT615-7S-19	-
Brushed Steel	PT615-7S-ST	PT615-70-ST



**Prisma Series  
Steel Table Legs, 2-3/8" Diameter 4 Leg Packs**



- Load bearing capacity of 660 lbs. per leg
- 2-3/8" diameter, 27-3/4" L (table height) and 34-1/4" L (counter height)
- Include separate brackets to attach the leg to the table and all necessary screws
- Legs have built in 1-1/8" adjustable feet
- Packs include: (4) legs, (4) brackets and screws

Finish	Table Height Item #	Counter Height Item #
Brushed Steel	PT330-70-ST	PT330-87-ST
Chrome	PT330-70-CH	PT330-87-CH
Glossy Black	PT330-70-BK	-
Matte Black	PT330-70-MT	PT330-87-MT



**Heidelberg Series  
Steel Table Legs, 3" Diameter**



- Load bearing capacity of 660 lbs. per leg
- 3" diameter, 27-3/4" L (table height), 34-1/4" L (counter height)
- The leg features a non-visible "adapter" used to attach the leg to a table
- Legs have built in 1-1/8" adjustable feet
- Packs include: (1) leg, (1) bracket, (1) adapter and screws

Finish	Table Height Item #	Counter Height Item #
Brushed Steel	PT620-7S-ST	PT620-8S-ST

**STEEL TABLE LEGS & TABLE BASES**

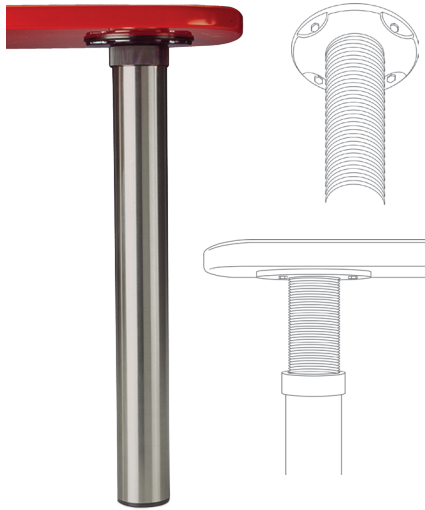

**Isola Series  
Steel Table Leg, 3" Diameter**



- Load bearing capacity of 660 lbs. per leg
- 3" diameter, 27-3/4" length (table height)
- Mounting plate is welded to leg extension and has a 6" diameter and four screws holes
- Legs can be extended by 9" by rotating the top of the leg
- Packs include: (1) leg and screws

Finish	Item #
Brushed Chrome	PT624-7S-ST



**Table Bases, T-Style,  
Cross-Style & Round**



- All tables bases include: floor protecting glides, a spider, a column, and a base
- Spiders and columns are made of steel and bases are made of cast iron
- All table bases require assembly
- Available in two heights: standard height is 29" and bar height is 40-3/4"

	Item #	Base Spread	Column Diameter	Mount Plate (Spider) Size	Height	Finish
<b>T-Style</b>						
A	PT2001-28-MT	5" x 22"	3"	7-1/2"W x 7-1/2"L	29"	Black Matte
<b>Cross-Style</b>						
B	PT2022-28-MT	22" x 22"	3"	7-1/2"W x 7-1/2"L	29"	Black Matte
	PT2002-40-MT	22" x 30"	3"	7-1/2"W x 7-1/2"L	40-3/4"	Black Matte
	PT2030-28-MT	30" x 30"	3"	7-1/2"W x 7-1/2"L	29"	Black Matte
	PT2036-28-MT	36" x 36"	4"	8"W x 8"L	29"	Black Matte
<b>Round</b>						
C	PT3022-29-MT	22" Diameter	3"	7-1/2"W x 7-1/2"L	29"	Black Matte
	PT3030-29-MT	30" Diameter	4"	8"W x 8"L	29"	Black Matte

A  
B  
C  
D  
E  
F  
G  
H  
I  
J  
K  
L  
M  
N  
O  
P  
Q  
R  
S  
T  
U  
V  
W  
X  
Y

**A FURNITURE LEVELERS**

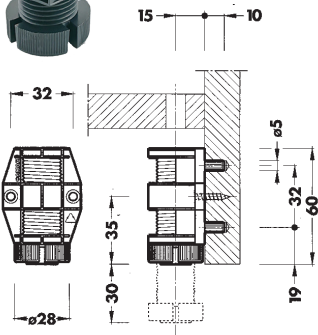

**Economy ABS Plastic Leveler, One Piece**

- Designed to attach to panel
- Two 5mm dowels spaced 32mm apart for line boring and 2 holes for wood screws
- Can be adjusted with slotted screwdriver
- Leveler's base extends 1"



Item #	Weight Capacity	Base Diameter	Height	Sold In
PT302	170 lbs.	1-1/16"	1-7/64"	Per Each

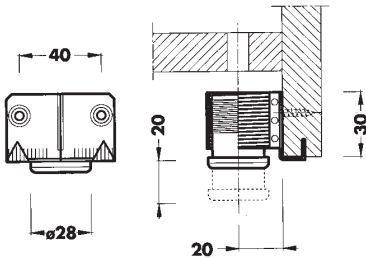
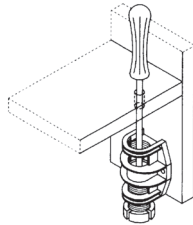

**Regular Duty Metal Leveler, One Piece**

- Designed to attach to panel
- Metal leveler with threaded ABS insert
- Slotted screwdriver adjustment
- Leveler's base extends 1"



Item #	Weight Capacity	Base Diameter	Height	Sold In
PT300	220 lbs.	1-1/8"	1-9/32"	Per Each

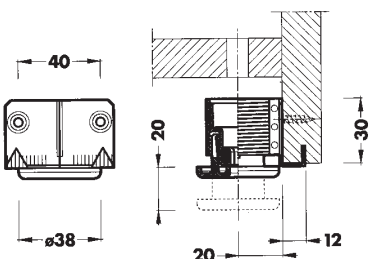
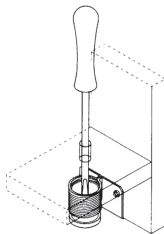

**Heavy Duty Metal Leveler, One Piece**

- Designed to attach to panel
- Metal leveler with metal insert and large floating ABS foot
- Adjusted with hex key (key included)
- Leveler's base extends 1"



Item #	Weight Capacity	Base Diameter	Height	Sold In
PT300HD	330 lbs.	1-1/2"	1-5/16"	Per Each

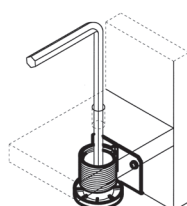

**PLASTIC CABINET LEVELERS**

**A. Screw-in Kit**

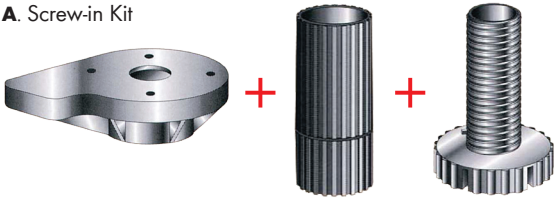

**B. Dowel Kit**

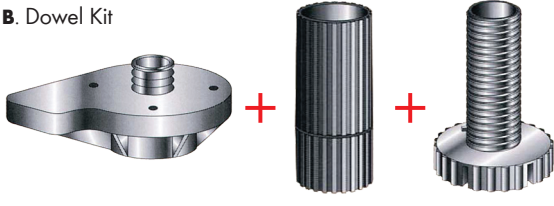

**Plastic Cabinet Leveler Kits  
Heavy Duty Leveler,  
Leveler Tube & Socket Kits**



- Hardware Concepts' Heavy Duty cabinet leveler kits
- Leveler/Socket Kits are available in two versions: screw in (A) and 25/32" diameter dowel sockets (B) and all levelers are adjustable from 3-7/8" to 5-3/4" with a 2-1/4" diameter foot
- Optional items:
  - Toe Kick Clips are available in two versions: screw in (C) and spline (D)
  - Leveler Extension (E) is available in one version: 1-1/2" extension
  - 25/32" Diameter Cover Caps (F) for Dowel Sockets
- Maximum height of leveler with leveler extension is 7-1/4"
- 1,500 lbs. maximum weight capacity for a set of 4 levelers
- Made of High Impact Polypropelene

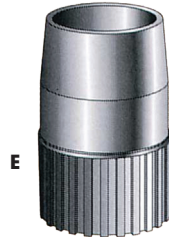
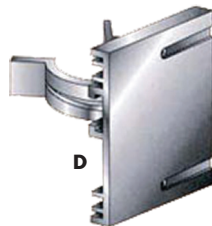
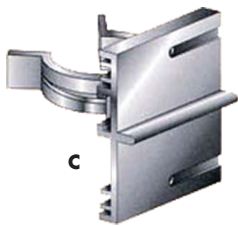

Item #	Finish	Product Dimensions	Description	Sold In	
<b>Adjustable Plastic Leveler/Socket Kit</b>					
A	HC5600000-BK	Black	Adj. Height - 3-7/8" to 5-3/4" w/ 2-1/4" Diameter Foot	Kit Includes: Adj. Leveler, Leveler Tube & Screw In Socket, with a weight capacity of 375 lbs. per leveler	100/Box
B	HC5620000-BK	Black	Adj. Height - 3-7/8" to 5-3/4" w/ 2-1/4" Diameter Foot	Kit Includes: Adj. Leveler, Leveler Tube & Dowel Socket w/ 25/32" Dia. Dowel, with a weight capacity of 375 lbs. per leveler	100/Box
<b>Optional - Toe Kick Clip</b>					
C	HC5696-000	-	2-1/8"H x 1-1/2"W	Toe Kick Clips Includes: White Clip & Black Screw In Plate	Per Each
D	HC5695-000	-	1-3/8"H x 1-3/8"W	Toe Kick Clip Includes: White Clip & Black Spline Plate	Per Each
<b>Optional - Leveler Extension</b>					
E	HC5675000-BK	Black	1-1/2" Extension Height	Designed for Leveler HC5600 Series Kits to add 1-1/2" Height for a Total Height of 7-1/4"	Per Each
<b>Optional - Dowel Socket Cover Caps</b>					
F	HC5720014-BK	Black	25/32" Diameter	Designed for HC5620 Series Kits to Cover the Socket's Dowel	Per Each

A  
B  
C  
D  
E  
F  
G  
H  
I  
J  
K  
L  
M  
N  
O  
P  
Q  
R  
S  
T  
U  
V  
W  
X  
Y

**A PLASTIC CABINET LEVELERS**

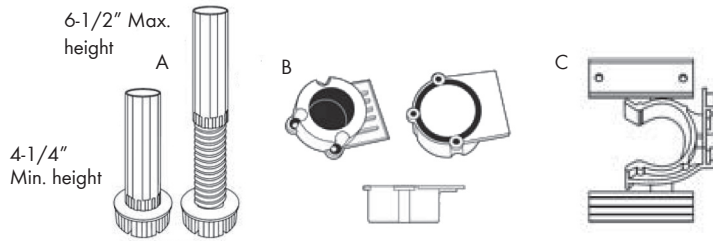

**Leveler, Socket & Toe Kick Clip**

- Made of high impact polypropylene
- Black finish



Item #	Product Dimensions	Description	Sold In
<b>Adjustable Plastic Leveler</b>			
A	HC5858335-BK	Adj. Height - 4-1/4" to 6-1/2" w/ 1-5/8" Dia. Foot	Weight capacity of 420 lbs. per leveler
<b>Plastic Socket</b>			
B	HC5800000-BK	Screw-In Socket	Per Each
<b>Toe Kick Clip</b>			
C	HC5897000	Plastic Clip w/Screw-On & Spline	Per Each
D	HC5899000	Metal Clip - with Plastic Plate w/Double Sided Adhesive	Per Each

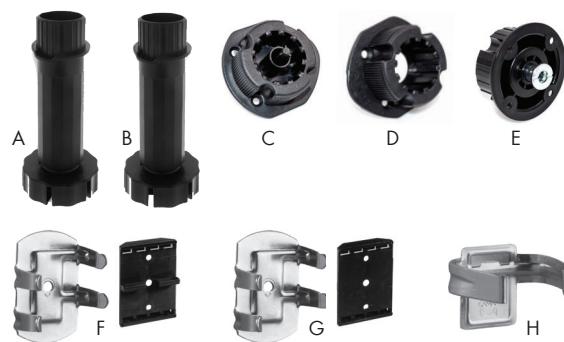

**Plastic Levelers, Sockets & Toe Kick Clips**

- Adjustable plastic levelers allow for precision adjustment of cabinetry
- All leveler components are made of virgin ABS
- Levelers have a weight bearing capacity of 330 lbs. per leveler



Type	Item #	Description	Sold In
<b>Cabinet Levelers</b>			
A	1" Adjustable	PT415-10-P2	3-3/4"-4-3/4", Black Plastic
	1" Adjustable	PT415-11-P2	4-1/8"-5-1/8", Black Plastic
	1" Adjustable	PT415-13-P2	4-7/8"-5-7/8", Black Plastic
B	2-1/2" Adjustable	PT418-10-P2	3-3/4"-6-1/4", Black Plastic (NOTE: Does not work with Socket PT840-00-RIB)
<b>Cabinet Leveler Sockets</b>			
C	10mm Dowel & Screw Mount	PT840-10-P2	With "V" Plate, 10mm Dowel and Screw Mount, Black Plastic
	15mm Dowel & Screw Mount	PT840-15-P2	With "V" Plate, 15mm Dowel and Screw Mount, Black Plastic
D	Screw Mount with "V" Plate	PT840-H5-P2	With "V" Plate, Screw Mount, Black Plastic
E	Hollow Bolt & Screw Mount	PT840-00-R1	With M10 Hollow Bolt, Screw Mount, Black Plastic (NOTE: Does not work with Leveler PT418-10-P2B)
<b>Toe Kick Clips</b>			
F	Black	PT202ANC2	4-Finger Clip/Groove Mount
G	Black	PT202V1T2	4-Finger Clip/Screw Mount
H	Black	PT228G	2-Finger Clip/Groove Mount
I	Black	PT228S	2-Finger Clip/Screw Mount

**PLASTIC CABINET LEVELERS**



**Cabinet Leg Levelers**

**Titus**

- Legs are made of plastic w/black finish
- Drilling Distance: 24mm

	Item #	Description	Height Adjustment	Sold In
A	TI02570-BK	Adj. leg leveler	2.36" - 3.54"	Per Each
	TI02666LA	Adj. leg leveler	3.64" - 5.91"	Per Each
	TI02653-BK	Adj. leg leveler	4.92" - 7.28"	Per Each
B	TI02571-BK	1.97"H leg extension	-	Per Each



**Cabinet Leg Leveler Sockets**

**Titus**

- Sockets are made of plastic w/black finish

	Item #	Description	Sold In
A	TI02558-BK	Knock-in socket w/10mm dowel	Per Each
B	TI02559-BK	Screw-on socket	Per Each
C	TI02560-BK	Socket w/15mm rivet	Per Each



**Cabinet Leg Leveler Plinths**

**Titus**

- Plinths are made of plastic w/black finish

	Item #	Description	Sold In
A	TI02523-BK	Knock-in plinth clip	Per Each
B	TI02578-BK	Screw-on plinth clip	Per Each



**Cabinet Leg Leveler Set**

**Titus**

- Set is made of plastic w/black finish
- Leg levelers height adjustment: 3.64" - 5.91"

Item #	Description	Sold In
TI02609-BK	(4) Legs, (4) Screw-on sockets & (2) Screw-on plinths	Per Set



**One Piece Leveler/Socket, Black Finish**

- Leveler & socket combo, (socket molded to leveler)
- All plastic levelers are made of virgin ABS which provides extra strength and stability
- Leveler is 3-3/4" tall fully compacted and extends to a maximum of 5-3/4"
- Plastic levelers and sockets weight capacity per unit: 330 lbs.
- Includes hollow bolt to mount socket/leveler to cabinet

Item #	Height Range	Weight Capacity	Mounting	Sold In
PT446P2S3K	Height Adj. 3-3/4" - 5-3/4"	330 lbs.	Hollow-Bolt	Per Each

**A METAL CABINET LEVELERS**

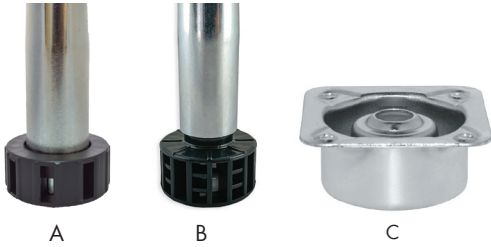

**Metal Cabinet Levelers, Sockets & Toe Kick Clips**



- Adjustable metal levelers allow for precision adjustment of cabinetry
- Metal levelers have ABS plastic feet
- Levelers feature tapered tops, which ensures a tight connection with the socket
- Levelers have a weight bearing capacity of 330 lbs. per leveler



	Item #	Description	Mounting	Finish	Sold In
<b>Metal Leveler</b>					
A	PT3451002	Height Adj. 4" - 6"	-	Metal	Per Each
B	PT3501002	Height Adj. 3-1/2" - 4-3/4"	-	Metal	Per Each
<b>Metal Sockets</b>					
C	PT835E100	2-3/8" Square Screw-In Socket	Screw-In	Metal	Per Each
<b>Toe Kick Clips</b>					
D	PT202ANC2	4-Finger Clip	Groove Mount	Black	Per Each
E	PT202V1T2	4-Finger Clip	Screw Mount	Black	Per Each
F	PT228G	2-Finger Clip	Groove Mount	Black	Per Each
G	PT228S	2-Finger Clip	Screw Mount	Black	Per Each

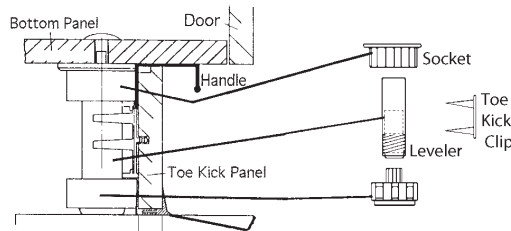
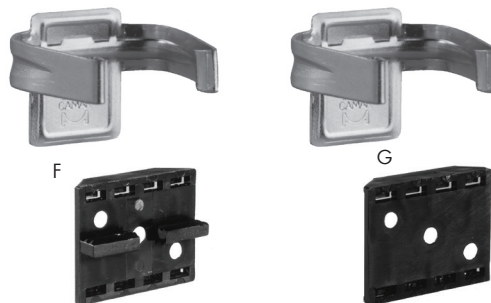

**T 4-PIECE METAL CABINET LEVELER SET**



**4-Piece Metal Cabinet Leveler Set**



- Levelers have a weight bearing capacity of 330 lbs. per leveler
- Metal levelers have ABS plastic feet
- **Set Includes:**
  - (4) Metal Leg Levelers (PT3451002), height adj. 4"-6"
  - (4) Metal Sockets (PT835E100), screw mount
  - (2) Toe Kick Clips (PT202V1T2), screw mount w/4-fingers

Item #	Description	Sold In
PT400-028B	4-Piece Leg Leveler Set	Per Set



**METAL CABINET LEGS**



**Foldable Plastic Cabinet Levelers  
One Piece Leveler/Socket/Toe Kick Clip**



- Screw-on version is a leveler/socket/toe kick clip that is constructed to form a single piece
- Adjustable plastic leveler/socket/toe kick clip combos allow for precision adjustment of cabinetry
- All plastic levelers are made of virgin ABS which provides extra strength and stability
- Leveler is 3-1/2" tall, fully compacted and extends to a maximum of 6-1/2"
- One simple motion takes the leveler to the desired position
- Includes: leveler/socket and both push-down and adhesive toe kick clips

Item #	Product Dimension	Mounting	Finish	Sold In
PT478-10-P2	Height Adj. 3-1/2" to 6-1/2"	Screw-On	Black	Per Each



**Leveling Wedge, Breakaway**



- Black nylon wedge with 8 section snap-off units sized from 1/16" to 5/16" thick
- Complete/full wedges are 13/16" wide x 4" long

Item #	Sold In
SYP460	Per Each



**Como Series  
Steel Cabinet Legs, 2" Diameter**



- Weight capacity per leg is 660 lbs.
- 1-1/8" adjustable black plastic foot
- All cabinet legs are individually packed to include cabinet leg, 3" square mounting plate (screws are not included)

Alumina Item #	Brushed Steel Item #	Chrome Item #	Matte Black Item #	Height	Sold In
PT552-10-AO	PT552-10-ST	PT552-10-C1	PT552-10-19	4"	Per Each



**Sedona Series  
Aluminum Cabinet Leg**



- Made of 100% aluminum
- Bottom of legs feature an attached thick felt pad
- 1" adjustable foot
- Includes Mounting Plate

Item #	Finish	Height	Foot Size	Mounting Plate Size	Sold In
PT08-6-M	Matte Aluminum	6"	1-3/4 Diameter	3-1/8"W x 3-1/8"L	Per Each

A  
B  
C  
D  
E  
F  
G  
H  
I  
J  
K  
L  
M  
N  
O  
P  
Q  
R  
S  
T  
U  
V  
W  
X  
Y

**A GLIDES**

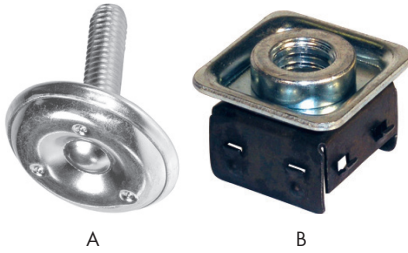

**Leveling Swivel Glides, Adjustable**



- Glides have either metal or plastic floor base and swivel from stem
- Optional 1" square metal insert bushing is designed for the 1" square table legs; sold separately

Item #	Base Material	Base Color/Shape	Base Dia.	Stem Thread (Dia. x Gauge)	Stem Length
<b>Swivel Glides</b>					
A P7433-24	Plastic	Nickel/Round	1-1/8"	1/4"-20	1"
A P9601-24	Metal	Zinc/Round	1-3/4"	3/8"-16	1-1/4"
<b>Optional, Metal Insert Bushing for 1" Square Legs</b>					
B P3066-4-4S-55	Metal	Black/Metal/Square	-	1/4"-20	-
B P3060-6-4S-55	Metal	Black/Metal/Square	-	3/8"-16	-

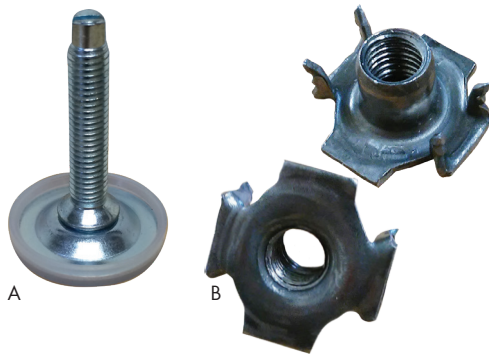

**Leveling Swivel Glide Systems**



- Slotted tops, swivel base and clear protective plastic cap bottom
- Glides, t-nuts and u-brackets have corresponding metric M8 thread pattern
- Glides are available in 2", 2-3/4" and 4" total lengths
- T-nuts are .43"H

Item #	Glide Length
<b>Glides - 33mm Dia. (Approx. 1-5/16")</b>	
A WDT4062	2"
A WDT4064	2-3/4"
A WDT4066	4"
<b>T-Nuts</b>	
B WDT4090	-
<b>U-Bracket - 1-1/2" x 1-1/2" x 1-1/2"</b>	
C WDT4060	-

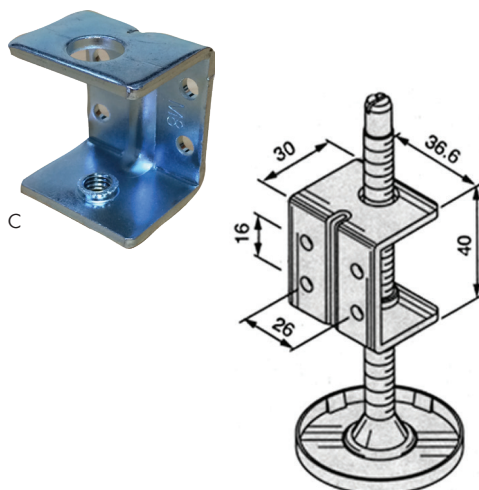

**GLIDES**



**Windsor Adjustable Glide**

- Adjustable glide, light duty (not non-skid)
- Sold per each

Item #	Base Dia.	Thread	Stem Length	Base Material	Base Color
P76327-2510	1-1/8"	1/4"-20	1"	Plastic	White
P76321-2510	1-1/8"	1/4"-20	1"	Plastic	Black
P76327-3110	1-1/8"	5/16"-18	1"	Plastic	White



**Monaco Adjustable Glide**

- Adjustable glide, light duty (not non-skid)
- Sold per each

Item #	Base Dia.	Thread	Stem Length	Base Material	Base Color
P78327-3115	1-1/8"	5/16"-18	1-1/2"	Plastic	Nickel-Plated Steel Shell



**Samson Adjustable Glide**

- Non-skid adjustable glide, medium duty
- Sold per each

Item #	Base Dia.	Thread	Stem Length	Base Material	Base Color
P67490-2510	1-1/8"	1/4"-20	1"	Vinyl	Black
P67490-3110	1-1/8"	5/16"-18	1"	Vinyl	Black



**Silencer Adjustable Glide**

- Cushioned adjustable glide, medium duty
- Sold per each

Item #	Base Dia.	Thread	Stem Length	Base Material	Base Color
P75001-5741	1-1/4"	1/4"-20	1"	Steel	Steel
P75001-5541	15/16"	1/4"-20	1"	Steel	Steel



**Cushion Adjustable Glide**

- Cushioned adjustable glide, medium duty
- Sold per each

Item #	Base Dia.	Thread	Stem Length	Base Material	Base Color
DHADJC7814	7/8"	1/4"-20	1"	Steel	Steel



**Yukon Adjustable Glide**

- Non-skid adjustable glide, heavy duty
- Sold per each

Item #	Base Dia.	Thread	Stem Length	Base Material	Base Color
SU7532-5S	1-3/8"	5/16"-18	1-1/2"	Thermoplastic Rubber	Nickel-Plated Steel Shell



**Titan Adjustable Glide**

- Non-skid adjustable glide, heavy duty
- Sold per each

Item #	Base Dia.	Thread	Stem Length	Base Material	Base Color
P75202-6363	1-3/8"	5/16"-18	1-1/2"	Thermoplastic Rubber	Nickel-Plated Steel Shell



**A GLIDES**

B  
C  
D  
E  
F  
G  
H  
I  
J  
K  
L  
M  
N  
O  
P  
Q  
R  
S  
T  
U  
V  
W  
X  
Y



**Nail Glides**

- Base made of plastic
- Sold per thousand



Base Diameter	Nail Size	Plastic Base Color	1,000/Box Item #
5/8"	1/16"Thick x 3/4"L	White	PTG-58WH
3/4"	1/16"Thick x 3/4"L	Brown	PTG-BN
3/4"	1/16"Thick x 3/4"L	White	PTG-WH
7/8"	1/16"Thick x 3/4"L	White	PTG-78WH

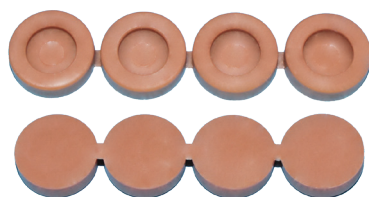

**Plastic Glide Strips, Staple-On**

- Strip of 4 allows easy stapling of one button then a quick twist frees remaining buttons
- 5/8" outside diameter x 3/16" thick with interior diameter of 3/8" to apply staple
- Sold in full box quantities



Item #	Glide Color	Sold In
BA295T-TN	Tan	Per Each



**Drawer Bumpers  
Screw-On**

- Made of Plastic
- Sold without screws



	Size	Description	White Item #	Almond Item #
A	1/2"Thick x 1"L	With Reference Tab	BA1937-WH	BA1937-AL
B	1/2"Thick x 1-1/4"L	With Reference Tab	BA4602-WH	BA4602-AL
C	1/2"Thick x 1-1/4"L	No Reference Tab	BA1938-WH	BA1938-AL
D	3/4"Thick x 2"L	With Reference Tab	BA1939-WH	BA1939-AL



C D

**BUMPERS**



A



B



C



D

**Bumpers**

- Easy “Peel-Off” & “Quick Stick”
- Vibration and Shock Dampening
- Crack-Resistant and Resilient
- Non-Staining and Non-Marring
- RoHS Compliant
- Sold by the sheet in full bag quantities

NOTE: Items with “SD” in item number denote “Sound Dampening”



	Item #	Color	Size	Bumpers per Sheet	Sheets per Bag
<b>A. Hemispherical</b>	WRBS02-BLK	Black	0.437”Dia x 0.2”H	50	5
	WRBS02-BRN	Brown	0.437”Dia x 0.2”H	50	5
	WRBS02-CLR	Clear	0.437”Dia x 0.2”H	50	5
	WRBS02-WHT	White	0.437”Dia x 0.2”H	50	5
	WRBS12-BLK	Black	0.375”Dia x 0.15”H	50	6
	WRBS12-CLR	Clear	0.375”Dia x 0.15”H	50	6
	WRBS12SD-CLR	Clear	0.375”Dia x 0.15”H	50	6
	WRBS12-WHT	White	0.375”Dia x 0.15”H	50	6
	WRBS27-CLR	Clear	0.335”Dia x 0.85”H	75	6
	WRBS07-BLK	Black	0.312”Dia x 0.085”H	75	6
	WRBS07-CLR	Clear	0.312”Dia x 0.085”H	75	6
	WRBS07-WHT	White	0.312”Dia x 0.085”H	75	6
<b>B. Specialty</b>	WRBS33-CLR	Clear	0.5”Dia x 0.14”H	50	4
	WRBS58-CLR	Clear	0.5”Dia x 0.2”H	50	4
<b>C. Cylindrical</b>	WRBS80-CLR	Clear	0.65”Dia x 0.4”H	32	4
	WRBS01-BRN	Brown	0.5”Dia x 0.14”H	50	4
	WRBS01-CLR	Clear	0.5”Dia x 0.14”H	50	4
	WRBS01SD-CLR	Clear	0.5”Dia x 0.14”H	50	4
	WRBS06-CLR	Clear	0.5”Dia x 0.25”H	50	4
	WRBS34-BLK	Black	0.4”Dia x 0.125”H	40	7
	WRBS34-CLR	Clear	0.4”Dia x 0.125”H	40	7
	WRBS34-WHT	White	0.4”Dia x 0.125”H	40	7
WRBS67-CLR	Clear	0.375”Dia x 0.19”H	50	5	
<b>D. Square</b>	WRBS32-CLR	Clear	0.5”Sq x 0.12”H	50	4

A  
B  
C  
D  
E  
F  
G  
H  
I  
J  
K  
L  
M  
N  
O  
P  
Q  
R  
S  
T  
U  
V  
W  
X  
Y

**A POLYURETHANE BUMPERS**

B  
C  
D  
E  
F  
G  
H  
I  
J  
K  
L  
M  
N  
O  
P  
Q  
R  
S  
T  
U  
V  
W  
X  
Y



**Polyurethane Bumpers  
Adhesive Backed**



- Made of durable polyurethane polymer
- High quality pressure sensitive adhesive backing

	Item #	Size	Shape	Color	Sold In	Box Qty
A	BS1	1/2" Dia. x 9/64" Thick	Cylindrical	Clear	200 Bumpers Per Sheet	5,000
B	BS1-WH	1/2" Dia. x 9/64" Thick	Cylindrical	White	200 Bumpers Per Sheet	5,000



**Sound Dampening Bumpers  
Adhesive Backed**



- Made of durable polyurethane polymer
- High quality pressure sensitive adhesive backing

	Item #	Size	Shape	Color	Sold In	Box Qty
A	BS33-SD	1/2" Dia. x 5/32" Thick	Cylindrical	Clear	200 Bumpers Per Sheet	5,000
B	BS58-SD	1/2" Dia. x 7/32" Thick	Cylindrical	Clear	200 Bumpers Per Sheet	5,000
C	BS12-SD288	3/8" Dia. x 5/32" Thick	Hemispherical	Clear	288 Bumpers Per Sheet	7,200



**Polyurethane Premium  
Round Shaped, Adhesive Backed**



- Premium self adhesive bumpers provide protection
- Close doors without an annoying thud
- High quality polyurethane stays soft, no drying or cracking over time

	Item #	Color	Size	Sold In
A	G31002	Clear	7/16" Dia. x 1/8" Thick	500/Box
B	G31004-43	Clear	7/16" Dia. x 1/16" Thick	500/Box
C	G63481-43	Clear Airsoft	15/32" Dia. x 3/16" Thick	500/Box

# BUMPERS



Hemisphere Shaped



Hexagon/Cone Shaped



Hexagon/Hemisphere Shaped

## 3M "Bumpon" Bumpers



- 3M brand adhesive backing which bonds fast and permanently to most clean, dry and smooth surfaces
- Resilient material will not dry out, rot or become brittle over time
- Sold in per sheet or per box

Thickness	Size	Transparent Item #	Sold In
<b>Hemisphere Shaped</b>			
5/32"	3/8" Diameter	MH6506	5,000/Box
<b>Hexagon/Cone Shaped</b>			
1/8"	7/16" Diameter	MH6553	132/Sheet
<b>Hexagon/Hemisphere Shaped</b>			
5/32"	7/16" Diameter	MH6561	132/Sheet

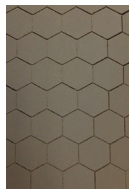
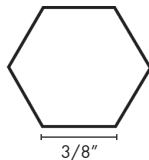

## Urethane Foam Bumpers, Hex Shaped

- Hex-shaped soft urethane sponge pads with self adhesive backs
- Sold by the roll



Item #	Size	Color	Roll Qty
DF38T	3/8"Dia. x 1/8"Thick	Tan	5,000
DF38W	3/8"Dia. x 1/8" Thick	White	5,000

Visit us on our website: [wurthlac.com](http://wurthlac.com)

The screenshot shows the WÜRTH website interface. At the top, there is a search bar with the text "Enter search criteria here" and a shopping cart icon showing "\$0.00". Below the navigation bar, there are three main promotional banners:

- 3M XTRACT ABRASIVES:** "LEAVE THE DUST BEHIND WITH 3M XTRACT™ ABRASIVES! TRY-IT PACKS! 5" Disc, 6" Disc".
- NOW HIRING!** "Apply at: [wurthlac.com/careers](http://wurthlac.com/careers)".
- SUPPLY CHAIN CHALLENGES? We have you COVERED.** "LEARN MORE".

A  
B  
C  
D  
E  
F  
G  
H  
I  
J  
K  
L  
M  
N  
O  
P  
Q  
R  
S  
T  
U  
V  
W  
X  
Y

A  
B  
C  
D  
E  
F  
G  
H  
I  
J  
K  
L  
M  
N  
O  
P  
Q  
R  
S  
T  
U  
V  
W  
X  
Y

**BUMPERS/STOPS**



**Cork Door Bumpers**

- Made of cork
- Natural finish
- Sold by the roll



Item #	Dimensions	Sold In
DCCP5	3/8"Dia. x 3/32"Thick	5,000/Roll



**Felt Door Bumpers**

- Adhesive backing for easy surface mount
- Made of felt
- Sold by the roll



Item #	Dimensions	Color	Sold In
DCFP1WH	3/8"Dia. x 1/8"Thick	White	1,000/Roll
DCFP5WH	3/8"Dia. x 1/8"Thick	White	5,000/Roll



**Cabinet Door Protector Bumpers**

- Protects doors from being unintentionally marred from drawer pull-outs
- Bumpers have PSA backing which can be used by removing protective liner
- Bumpers can be applied with supplied PSA or screwed in, or both
- Sold by the pack



Item #	Description	Pack Qty
FCDWRBMPR	Drawer Bumper, White	10



**BUMPERS/STOPS**



**Inset Door Stops, Adjustable**



- Constructed of soft rubber
- Door stops are .575" in diameter and .3125" tall
- Off center screw hole allows door stop to be rotated to varied distances from door
- Sold by the pack

Item #	Color	Pack Qty
<b>Without Screws</b>		
FCEDS-BN	Dark Brown	10
FCEDS-CL	Clear	10
FCEDS-WH	White	10
<b>With Screws</b>		
FCEDS-BNWS	Dark Brown	10
FCEDS-CLWS	Clear	10
FCEDS-WHWS	White	10
<b>Bulk, Without Screws</b>		
FCEDS-BN100	Dark Brown	100
FCEDS-CL100	Clear	100
FCEDS-WH100	White	100

A  
B  
C  
D  
E  
F  
G  
H  
I  
J  
K  
L  
M  
N  
O  
P  
Q  
R  
S  
T  
U  
V  
W  
X  
Y



**Inset Door Stop, Plastic**



- Used primarily as a door stop for inset doors hung with European concealed hinges to ensure a "flat" cabinet face
- European hinges "over-close" without the cabinet side to rest against, the door goes beyond 90°
- By mounting this stop on the cabinet floor, the door's closing is stopped at 90 degree flat position
- Specifications: 7/16"W x 1/2"H
- Sold in full box quantities

Item #	Color	Box Qty
HGH950CL1000	Clear	1000

**A PLATE MOUNTED CASTERS**

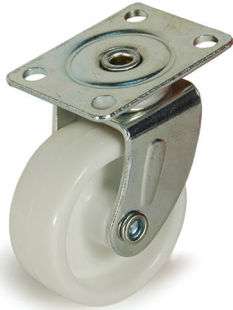

**Roller Swivel Furniture Casters Without Brake  
Light Duty, 65 lbs. Weight Capacity**



- Plate finish is Zinc with a white plastic wheel
- Smooth and easy rolling
- Plate size: 1-5/8" x 1-1/4"
- Applications: Office furniture, light duty carts, juvenile furniture

Item #	Wheel Dia.	Tread Width	Overall Height
DHCR158POZ	1-5/8"	5/8"	1-7/8"



**Double Ball-Bearing Swivel Casters  
Without Brake Light Duty, 70 to 80 lbs.  
Weight Capacity**



- Used for wood base office furniture
- Plate Size: 1-1/8" x 2"
- Plate Fastening: 2" x 1-3/16" with (4) #8 holes
- Finish: Copper Oxide with a soft black rubber wheel
- Sold in full box quantity only

Item #	Wheel Dia.	Weight Capacity	Overall Height	Box
SCPPY1.12	1-5/8"	70 lbs.	2-5/16"	100

**Visit us on our website: wurthlac.com**

The screenshot shows the Wurth website interface. At the top, there are navigation links for 'Wurth Louis and Company', 'Large Machinery Quote', and 'Feedback'. On the right, there are links for 'Register', 'Apply', 'Sign in', and 'En'. The main header features the WÜRTH logo, a search bar with the placeholder 'Enter search criteria here', and a shopping cart icon showing '\$0.00'. Below the header, there are two main promotional banners. The left banner is for 'Würth Louis and Company Introduces: RGB TUNABLE FLEXTAPE®', featuring an image of a modern kitchen with colorful lighting. The right banner is a 'NOW HIRING!' notice with the Wurth logo and the text 'Apply at: wurthlac.com/careers'. Below these banners, there is a 'SUPPLY CHAIN CHALLENGES? We have you COVERED.' banner with a 'LEARN MORE' button. At the bottom of the page, there are small navigation icons for '1', '2', '3', '4', and '5'.

**PLATE MOUNTED CASTERS**



Rigid without brake



Swivel with brake

**Swivel & Rigid Casters  
Medium Duty, 90 to 300 lbs. Weight Capacity**

- With side locking brake or without brake, rigid and swivel design
- Available in hard rubber, plastic and non-marking rubber wheel material types
- Finish is corrosion-resistant Zinc Plated



	Item #	Wheel Dia.	Tread Width	Wheel Material	Weight Capacity	Swivel Radius	Plate Size	Overall Height
Without Brake	DHCGD20PR	2"	15/16"	Plastic	125 lbs.	Rigid	1-1/2"W x 2-21/32"L	2-7/16"
	DHCGD20MRR	2"	15/16"	Non-Marking Gray	125 lbs.	Rigid	1-1/2"W x 2-21/32"L	2-7/16"
	DHCGD20HRR	2"	15/16"	Hard Rubber	125 lbs.	Rigid	1-1/2"W x 2-21/32"L	2-7/16"
	DHCGD20RS	2"	15/16"	Soft Rubber	90 lbs.	1-3/4"	1-7/8"W x 2-9/16"L	2-7/16"
	DHCGD20PS	2"	15/16"	Plastic	125 lbs.	1-3/4"	1-7/8"W x 2-9/16"L	2-7/16"
	DHCGD20MRS	2"	15/16"	Non-Marking Gray	125 lbs.	1-3/4"	1-7/8"W x 2-9/16"L	2-7/16"
	DHCGD20HRS	2"	15/16"	Hard Rubber	125 lbs.	1-3/4"	1-7/8"W x 2-9/16"L	2-7/16"
	DHCGD25HRR	2-1/2"	1-1/8"	Hard Rubber	200 lbs.	Rigid	2-1/4"W x 4-7/16"L	3-1/4"
	DHCGD25MRR	2-1/2"	1-1/8"	Non-Marking Gray	175 lbs.	Rigid	2-1/4"W x 4-7/16"L	3-1/4"
	DHCGD25PS	2-1/2"	1-1/8"	Plastic	175 lbs.	2-3/8"	2-3/4"W x 3-27/32"L	3-1/4"
	DHCGD25MRS	2-1/2"	1-1/8"	Non-Marking Gray	175 lbs.	2-3/8"	2-3/4"W x 3-27/32"L	3-1/4"
	DHCGD25HRS	2-1/2"	1-1/8"	Hard Rubber	200 lbs.	2-3/8"	2-3/4" x 3-27/32"L	3-1/4"
	DHCGD30PR	3"	1-1/4"	Plastic	220 lbs.	Rigid	2-1/2"W x 4-7/8"L	3-13/16"
	DHCGD30HRR	3"	1-1/4"	Hard Rubber	220 lbs.	Rigid	2-1/2"W x 4-7/8"L	3-13/16"
	DHCGD30MRR	3"	1-1/4"	Non-Marking Gray	225 lbs.	Rigid	2-1/2"W x 4-7/8"L	3-13/16"
	DHCGD30RS	3"	1-1/4"	Soft Rubber	125 lbs.	2-7/16"	3-1/8" W x 4-1/16"L	3-13/16"
	DHCGD30PS	3"	1-1/4"	Plastic	220 lbs.	2-7/16"	3-1/8" W x 4-1/16"L	3-13/16"
	DHCGD30HRS	3"	1-1/4"	Hard Rubber	220 lbs.	2-7/16"	3-1/8" W x 4-1/16"L	3-13/16"
	DHCGD30MRS	3"	1-1/4"	Non-Marking Gray	225 lbs.	2-7/16"	3-1/8" W x 4-1/16"L	3-13/16"
	DHCGD40HRR	4"	1-1/4"	Hard Rubber	300 lbs.	Rigid	2-3/4"W x 6"L	5"
DHCGD40PS	4"	1-1/4"	Plastic	225 lbs.	3-1/4"	4"W x 5-1/18"L	5"	
DHCGD40HRS	4"	1-1/4"	Hard Rubber	300 lbs.	3-1/4"	4"W x 5-1/18"L	5"	
With Brake	DHCGD20PSB	2"	15/16"	Plastic	125 lbs.	1-3/4"	1-7/8"W x 2-9/16"L	2-7/16"
	DHCGD20HR SB	2"	15/16"	Hard Rubber	125 lbs.	1-3/4"	1-7/8"W x 2-9/16"L	2-7/16"
	DHCGD20MR SB	2"	15/16"	Non-Marking Gray	125 lbs.	1-3/4"	1-7/8"W x 2-9/16"L	2-7/16"
	DHCGD25RSB	2-1/2"	1-1/8"	Soft Rubber	100 lbs.	2-3/8"	2-3/4"W x 3-27/32"L	3-1/4"
	DHCGD25PSB	2-1/2"	1-1/8"	Plastic	175 lbs.	2-3/8"	2-3/4"W x 3-27/32"L	3-1/4"
	DHCGD25HR SB	2-1/2"	1-1/8"	Hard Rubber	200 lbs.	2-3/8"	2-3/4"W x 3-27/32"L	3-1/4"
	DHCGD25MR SB	2-1/2"	1-1/8"	Non-Marking Gray	175 lbs.	2-3/8"	2-3/4"W x 3-27/32"L	3-1/4"
	DHCGD30RSB	3"	1-1/4"	Soft Rubber	125 lbs.	2-7/16"	3-1/8" W x 4-1/16"L	3-13/16"
	DHCGD30PSB	3"	1-1/4"	Plastic	220 lbs.	2-7/16"	3-1/8"W x 4-1/16"L	3-13/16"
	DHCGD30HR SB	3"	1-1/4"	Hard Rubber	220 lbs.	2-7/16"	3-1/8"W x 4-1/16"L	3-13/16"
	DHCGD30MR SB	3"	1-1/4"	Non-Marking Gray	225 lbs.	2-7/16"	3-1/8"W x 4-1/16"L	3-13/16"
	DHCGD40HR SB	4"	1-1/4"	Hard Rubber	300 lbs.	3-1/4"	4"W x 5-1/18"L	5"

A  
B  
C  
D  
E  
F  
G  
H  
I  
J  
K  
L  
M  
N  
O  
P  
Q  
R  
S  
T  
U  
V  
W  
X  
Y

A  
B  
C  
D  
E  
F  
G  
H  
I  
J  
K  
L  
M  
N  
O  
P  
Q  
R  
S  
T  
U  
V  
W  
X  
Y

## PLATE MOUNTED CASTERS

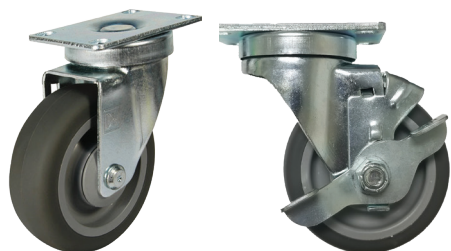

Rigid without brake

Swivel with brake

### Swivel & Rigid Casters Medium Duty, 220 to 300 lbs. Weight Capacity



- With or without brake, rigid and swivel types
- Available wheel material: Rubber, Non-Marking and Polyurethane
- Hardened raceway and yoke for extra strength

	Item #	Wheel Dia.	Tread Width	Wheel Material	Weight Capacity	Swivel Radius	Plate Size	Overall Height
Without Brake	DHCLM35P1TPS	3-1/2"	1-1/4"	Non-Marking (Gray)	220 lbs.	3-1/16"	2-3/8"W x 3-5/8"L	4-11/16"
	DHCLM4P1PUR	4"	1-1/4"	Polyurethane	275 lbs.	Rigid	2-3/8"W x 3-5/8"L	5-1/8"
	DHCLM4P1MR	4"	1-1/4"	Non-Marking (Gray)	240 lbs.	Rigid	2-3/8"W x 3-5/8"L	5-1/8"
	DHCLM4P1RR	4"	1-1/4"	Rubber	265 lbs.	Rigid	2-3/8"W x 3-5/8"L	5-1/8"
	DHCLM4P1PUS	4"	1-1/4"	Polyurethane	275 lbs.	3-1/2"	2-3/8"W x 3-5/8"L	5-1/8"
	DHCLM4P1MS	4"	1-1/4"	Non-Marking (Gray)	240 lbs.	3-1/2"	2-3/8"W x 3-5/8"L	5-1/8"
	DHCLM4P1RS	4"	1-1/4"	Rubber	265 lbs.	3-1/2"	2-3/8"W x 3-5/8"L	5-1/8"
	DHCLM5P1TPS	5"	1-1/4"	Soft Rubber	225 lbs.	4"	2-3/8"W x 3-5/8"L	6-5/32"
	DHCLM5P1PUS	5"	1-1/4"	Polyurethane	300 lbs.	4"	2-3/8"W x 3-5/8"L	6-5/32"
With Brake	DHCLM35P1TPSB	3-1/2"	1-1/4"	Non-Marking (Gray)	220 lbs.	3-1/16"	2-3/8"W x 3-5/8"L	4-11/16"
	DHCLM4P1TPSB	4"	1-1/4"	Non-Marking (Gray)	240 lbs.	3-1/2"	2-3/8"W x 3-5/8"L	5-1/8"
	DHCLM4P1RSB	4"	1-1/4"	Rubber	265 lbs.	3-1/2"	2-3/8"W x 3-5/8"L	5-1/8"
	DHCLM4P1PUSB	4"	1-1/4"	Polyurethane	275 lbs.	3-1/2"	2-3/8"W x 3-5/8"L	5-1/8"
	DHCLM5P1TPSB	5"	1-1/4"	Soft Rubber	225 lbs.	4"	2-3/8"W x 3-5/8"L	6-5/32"
	DHCLM5P1PUSB	5"	1-1/4"	Polyurethane	300 lbs.	4"	2-3/8"W x 3-5/8"L	6-5/32"



### Swivel Casters With Supreme Locking Brake Medium Duty, 265 to 275 lbs. Weight Capacity



- Total locking when engaged "Supreme" brake locks both wheel and yoke
- 4" wheel diameter
- Wheel material available: Soft Rubber Black and Polyurethane Blue
- Hardened raceway and yoke for extra strength
- Applications: Shop carts and equipment, industrial carts and store fixtures

Item #	Wheel Dia.	Tread Width	Wheel Material	Weight Capacity	Swivel Radius	Plate Size	Overall Height
DHCML4P1PUS	4"	1-1/4"	Polyurethane Blue	275 lbs.	3-1/2"	2-3/8"W x 3-5/8"L	5-1/8"
DHCML4P1RS	4"	1-1/4"	Soft Rubber Black	265 lbs.	3-1/2"	2-3/8"W x 3-5/8"L	5-1/8"

**PLATE MOUNTED CASTERS**



**Swivel & Rigid Casters Without Brake  
Low Profile, Heavy Duty, 440 lbs. Weight Capacity**

- Low profile twin wheel design for heavy weight capacity
- Excellent mobility
- Applications: Heavy equipment, stock carts



Item #	Wheel Dia.	Tread Width	Wheel Material	Weight Capacity	Swivel Radius	Plate Size	Overall Height
DHCBU3P2NR	3"	1-13/16"	Nylon	440 lbs.	Rigid	3-1/4"W x 4-1/4"L	4-3/16"
DHCBU3P2NS	3"	1-13/16"	Nylon	440 lbs.	2-5/16"	3-1/4"W x 4-1/4"L	4-3/16"



**Swivel & Rigid Casters Without Brake  
Heavy Duty, 400 to 1,000 lbs. Weight Capacity**

- Wheel material available in Molden Rubber (Rubber & Steel) and Phenolic
- Wheel diameter from 4" to 6"
- Leg double welded for extra strength



Item #	Wheel Dia.	Tread Width	Wheel Material	Weight Capacity	Swivel Radius	Plate Size	Overall Height
DHCMHD4PNR	4"	2"	Phenolic	800 lbs.	Rigid	3-15/16"W x 4-1/2"L	5-5/8"
DHCMHD4PNS	4"	2"	Phenolic	800 lbs.	3-3/16"	3-15/16"W x 4-1/2"L	5-5/8"
DHCMHD5MRS	5"	2"	Moldon Rubber	400 lbs.	3-7/8"	3-15/16"W x 4-1/2"L	6-1/2"
DHCMHD5PNS	5"	2"	Phenolic	900 lbs.	3-7/8"	3-15/16"W x 4-1/2"L	6-1/2"
DHCMHD6PNR	6"	2"	Phenolic	1000 lbs.	Rigid	3-15/16"W x 4-1/2"L	7-1/2"
DHCMHD6PNS	6"	2"	Phenolic	1000 lbs.	4-37/64"	3-15/16"W x 4-1/2"L	7-1/2"
DHCMHD8PNS	8"	2"	Phenolic	1000 lbs.	6"	3-15/16"W x 4-1/2"L	9-1/2"

**Visit us on  
our website:  
wurthlac.com**

The screenshot shows the WÜRTH website interface. At the top, there is a search bar with the text 'Enter search criteria here' and a shopping cart icon showing '\$0.00'. Below the navigation bar, there are three main promotional banners: 'LEAVE THE DUST BEHIND WITH 3M XTRACT™ ABRASIVES!' featuring a large image of a 3M Xtract abrasive disc; 'NOW HIRING!' with an image of a worker and the text 'Apply at: wurthlac.com/careers'; and 'SUPPLY CHAIN CHALLENGES? We have you COVERED.' with a 'LEARN MORE' button. At the bottom of the page, there are three categories: 'GOVERNMENT' (We are a SAM Approved U.S. Government Vendor), 'CATALOGS & LITERATURE' (Digital versions to download), and 'MACHINERY' (Explore our full line of woodworking machinery).

A  
B  
C  
D  
E  
F  
G  
H  
I  
J  
K  
L  
M  
N  
O  
P  
Q  
R  
S  
T  
U  
V  
W  
X  
Y

**A STEM MOUNTED CASTERS**



Threaded without Brake



Stem & Socket w/Bracket



Plate

**Twin Wheel Swivel Casters,  
Black Finish Light Duty, 70 to 85 lbs.  
Weight Capacity Plate**



- Stem/socket and threaded mounting - with or without brake
- Easy and smooth rolling on carpet or floor
- Applications: Office furniture, store fixture and all purpose carts

Item #	Wheel Dia.	Wheel Material	Weight Cap.	Mount Type	Stem Size (Dia. x Gauge x L) Plate Size (W x L)	Overall Height
<b>Without Brake</b>						
DHCT20T1BK	2"	Plastic	85 lbs.	Threaded	5/16"D - 18 Gauge x 1"L	2-1/8"
DHCT20S1BK	2"	Plastic	85 lbs.	Stem & Socket	5/16"D - 18 Gauge x 1-1/2" L	2-1/8"
DHCT15P1BK	1-1/2"	Plastic	70 lbs.	Plate	1-1/2"W x 1-1/2"L	1-3/4"
DHCT20P1BK	2"	Plastic	85 lbs.	Plate	1-1/2"W x 1-1/2"L	2-1/8"
<b>With Brake</b>						
DHCT20T1BKB	2"	Plastic	85 lbs.	Threaded	5/16"D - 18 Gauge x 1"L	2-1/8"
DHCT20S1BKB	2"	Plastic	85 lbs.	Stem & Socket	5/16"D - 18 Gauge x 1-1/2" L	2-1/8"
DHCT15P1BKB	1-1/2"	Plastic	70 lbs.	Plate	1-1/2"W x 1-1/2"L	1-3/4"
DHCT20P1BKB	2"	Plastic	85 lbs.	Plate	1-1/2"W x 1-1/2" L	2-1/8"

**Metal Hooded Swivel Casters  
Light Duty, 90 lbs. Weight Capacity,  
Stem & Socket Mount**



- Rubber ball wheels easily roll on carpet
- Application: Widely used on furniture for low-pile carpeting and all hard flooring
- Socket sold separately



Item #	Wheel Dia.	Finish	Stem Thread Size	Overall Height
DHCH20S1BR	2"	Brass	5/16"D x 1-1/2"L	2-1/2"
DHCH20S1CR	2"	Chrome	5/16"D x 1-1/2"L	2-1/2"
<b>Socket</b>				
DHMS516	-	Metal	5/16"D	1-1/2"

**STEM MOUNTED CASTERS**



**Threaded Stem Swivel Casters With Brake  
Light Duty, 100 lbs. Store Fixture Caster**

- Store fixture caster with octagonal upper cup for easy assembling
- Excellent floor protection has easy rolling, non-marking gray wheel



Item #	Wheel Dia.	Tread Width	Wheel Material	Swivel Radius	Stem Thread Size	Overall Height
DHCL130T6MSB	3"	1"	Non-Marking Gray	2-5/8"	1/2"D - 13 Gauge x 5/8"L	3-3/4"



Without brake



With brake

**Threaded Stem Mount Swivel Casters  
Light Duty, 66 to 110 lbs. Weight Capacity**

- With or without brakes
- Available in Black Rubber and Non-Marking Gray
- Embossed Zinc Plated yoke



Item #	Wheel Diameter	Tread Width	Wheel Material	Weight Capacity	Swivel Radius	Stem Thread Size	Overall Height
<b>Without Brake</b>							
DHCL20T2RS	2"	13/16"	Rubber	77 lbs.	1-13/16"	3/8" D - 16 Gauge x 1-1/4"L	2-5/8"
DHCL20T1RS	2"	13/16"	Rubber	77 lbs.	1-13/16"	5/16" D - 18 Gauge x 1" L	2-5/8"
DHCL20T2MS	2"	13/16"	Non-Marking	66 lbs.	1-13/16"	3/8"D - 16 Gauge x 1-1/4"L	2-5/8"
DHCL20T1MS	2"	13/16"	Non-Marking	66 lbs.	1-13/16"	5/16"D - 18 Gauge x 1" L	2-5/8"
DHCL30T2MS	3"	13/16"	Non-Marking	100 lbs.	2-3/8"	3/8"D - 16 Gauge x 1-1/4" L	3-5/8"
DHCL30T2RS	3"	13/16"	Rubber	110 lbs.	2-3/8"	3/8"D - 16 Gauge x 1-1/4" L	3-5/8"
<b>With Brake</b>							
DHCL20T2RSB	2"	13/16"	Rubber	77 lbs.	1-13/16"	3/8"D - 16 Gauge x 1-1/4"L	2-5/8"
DHCL20T1RSB	2"	13/16"	Rubber	77 lbs.	1-13/16"	5/16"D - 18 Gauge x 1" L	2-5/8"
DHCL20T2MSB	2"	13/16"	Non-Marking	66 lbs.	1-13/16"	3/8" D - 16 Gauge x 1-1/4"L	2-5/8"
DHCL20T1MSB	2"	13/16"	Non-Marking	66 lbs.	1-13/16"	5/16"D - 18 Gauge x 1" L	2-5/8"
DHCL30T2RSB	3"	13/16"	Rubber	110 lbs.	2-3/8"	3/8"D - 16 Gauge x 1-1/4" L	3-5/8"
DHCL30T2MSB	3"	13/16"	Non-Marking	110 lbs.	2-3/8"	3/8"D - 16 Gauge x 1-1/4" L	3-5/8"

A  
B  
C  
D  
E  
F  
G  
H  
I  
J  
K  
L  
M  
N  
O  
P  
Q  
R  
S  
T  
U  
V  
W  
X  
Y

**A STEM MOUNTED CASTERS**



**Threaded Stem Mount Casters  
Medium Duty, 220 lbs. Weight Capacity**

- With or without brake
- Made of Black Rubber
- Hardened raceway and yoke for extra strength



Item#	Wheel Dia.	Tread Width	Weight Capacity	Swivel Radius	Stem Thread Size	Overall Height
<b>Without Brake</b>						
DHCLM3T3RS	3"	1-1/4"	220 lbs.	2-3/4"	1/2" D-13 Gauge x 1-1/2" L	4-1/4"
<b>With Brake</b>						
DHCLM3T3RSB	3"	1-1/4"	220 lbs.	2-3/4"	1/2" D-13 Gauge x 1-1/2" L	4-1/4"



**Shopping Cart Casters  
Medium Duty, 200 lbs. Weight Capacity**

- Deeply embossed formed yoke
- Corrosion resistant Zinc Plated finish
- Excellent mobility



Item #	Wheel Dia.	Tread Width	Wheel Material	Weight Capacity	Swivel Radius	Stem Thread Size	Overall Height
DHCSC5T1PS	5"	1-1/4"	Polyurethane	200 lbs.	4"	1/2"D - 13 Gauge x 7/8"L	5-29/32"

**Visit us on  
our website:  
wurthlac.com**

The screenshot shows the WÜRTH website interface. At the top, there is a search bar with the text 'Enter search criteria here' and a shopping cart icon showing '\$0.00'. Below the search bar is a navigation menu with 'Shop By Category' and 'Home'. The main content area features a large advertisement for '3M XTRACT™ ABRASIVES!' with a 'TRY-IT PACKS!' offer for 5" and 6" discs. To the right, there are two smaller promotional boxes: one for 'NOW HIRING!' with an 'Apply at: wurthlac.com/careers' link, and another for 'SUPPLY CHAIN CHALLENGES? We have you COVERED.' with a 'LEARN MORE' link. At the bottom of the screenshot, there are three sections: 'GOVERNMENT' (We are a SAM Approved U.S. Government Vendor), 'CATALOGS & LITERATURE' (Digital versions to download), and 'MACHINERY' (Explore our full line of woodworking machinery).