

Full extension concealed runners

Basic components



Locking devices



Runners



Rear attachment options



Side-to-side adjustment

**1** Rotate side-to-side adjustment left or right equally on both locking devices. Drawer front moves in the same direction as rotation.

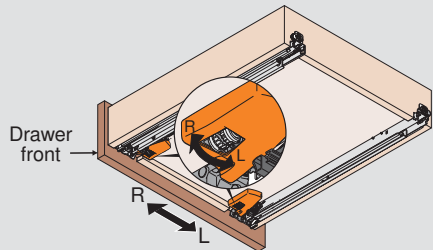

Maximum 1.5 (1/16") to left or right in both front and rear (tool-free)

**NOTE:** Side-to-side adjustment not available on T51.x8xx locking devices

Rear side-to-side adjustment

**2** After front side-to-side adjustment is made with the locking devices, rotate the rear side-to-side adjustment left or right to re-align the back of the drawer box with the front. Drawer back moves in the same direction as rotation.

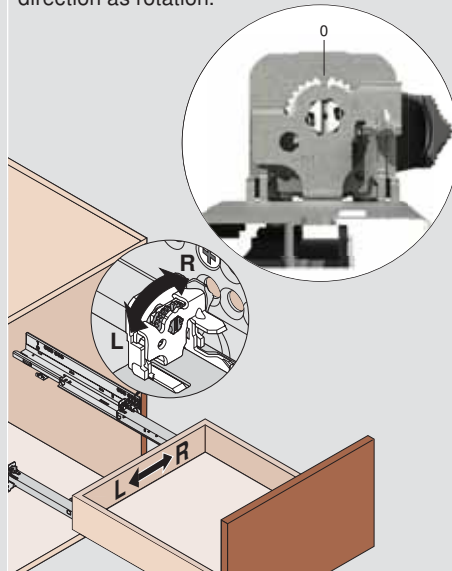

Height adjustment

**1** Press up on adjustment tab  
**2** Push towards back of drawer

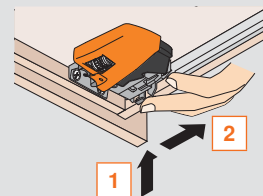

Maximum 3 (1/8") rise of drawer front (tool-free)

**NOTE:** Height and tilt adjustments available with all combinations of locking devices and runners

Tilt adjustment

Rotate the tilt adjustment lever on the rear of each runner to lift the back of the drawer and tilt the top of the drawer front forward

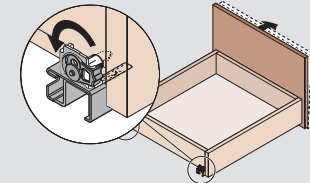

Maximum 5 (3/16") rise of drawer back (tool-free)

Depth adjustable locking device

Locking device  
**T51.1901.PS**  
with side-to-side,  
height and  
depth adjustment

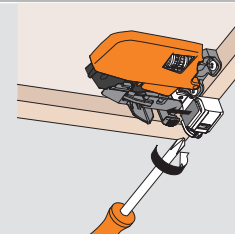

Turning the adjustment screw allows for up to a +2.5 (3/32") out adjustment

**NOTE:** For T51.1901.PS setback in inset applications, see page 5

Depth adjustment on runner

TANDEM 563 runners feature elongated holes that allow ±4.5 (3/16") depth adjustment

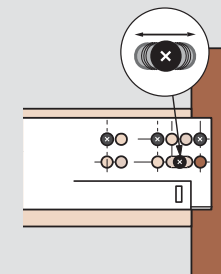

Drawer box specifications

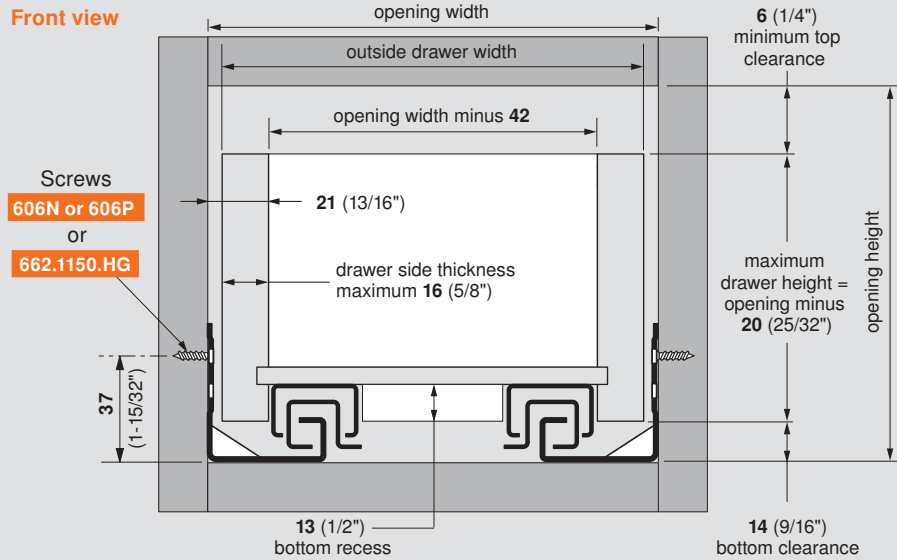

**NOTE:** Drawer side material thickness may vary. Accurate measurement of drawer side material thickness should be used when calculating outside drawer width using the table below. Inside drawer width **must** equal opening width minus 42 (1-21/32") for TANDEM to align and function optimally.

Calculating outside drawer width

For drawer side thickness	16 (5/8")	15 (19/32")	14 (9/16")	13 (1/2")	12 (15/32")
Deduct from opening width	10 (13/32")	12 (15/32")	14 (9/16")	16 (5/8")	18 (23/32")

**Example:** For 21" opening width and a 5/8" thick drawer, 21" minus 13/32" = 20-19/32" drawer width

Drawer insertion

Extend the concealed runners fully. Place the drawer on the runners and close. The locking devices automatically engage with the runners. Make adjustments if necessary.

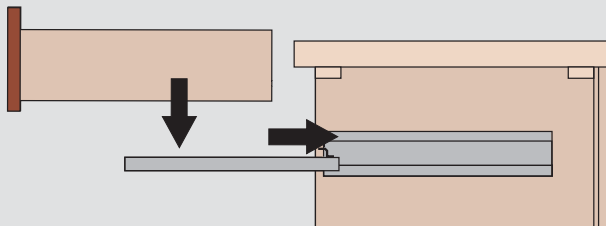

Preparing for hardware installation

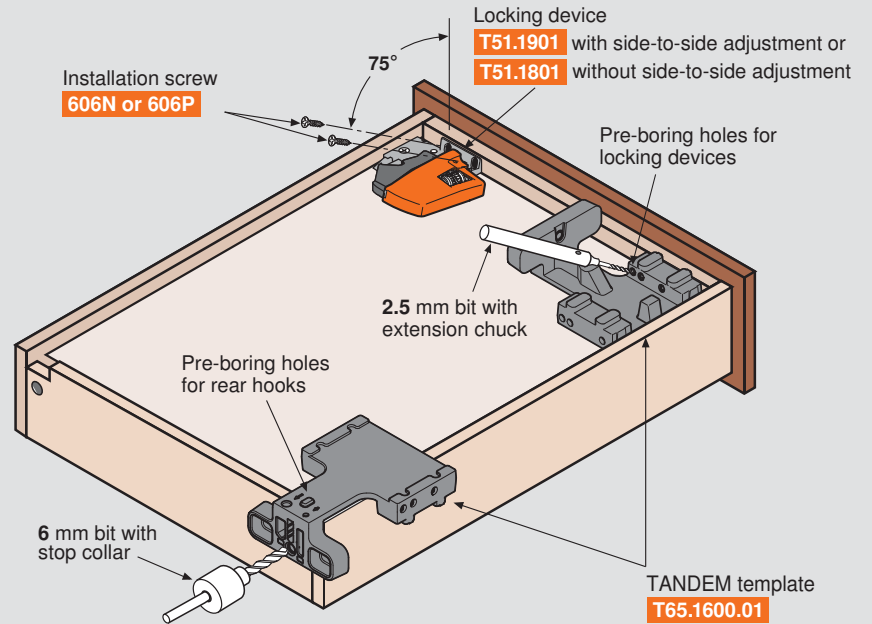

**NOTE:** Use of the T65.1600.01 TANDEM template is essential for accurate location and angle of pre-bored locking device holes and accurate boring for rear hook holes

Drawer removal

- 1 Squeeze orange handles on locking devices
- 2 Pull drawer straight out and up

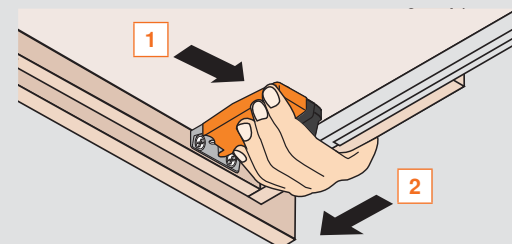



Runner mounting specifications

Side view

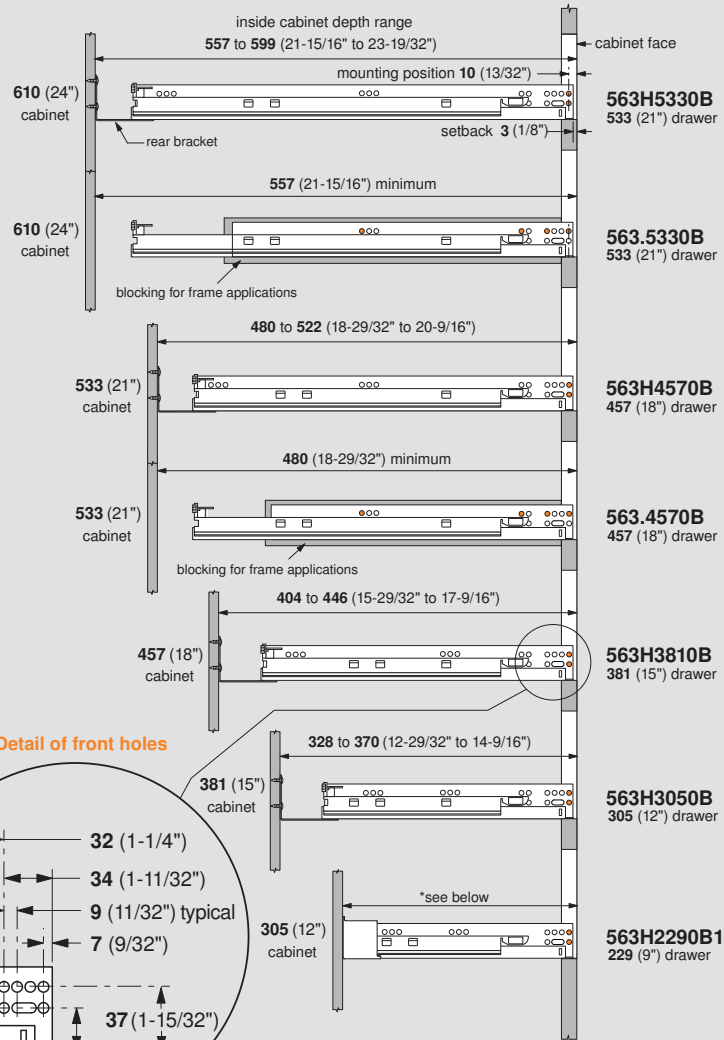

*Bracket	Maximum depth	Minimum depth
295.3700.21	282 (11-3/32")	266 (10-15/32")
295.3700.22	299 (11-25/32")	283 (11-5/32")

NOTE: \*These brackets are for 563H2290B10 only

NOTE: Orange dots indicate screw locations required to meet specified load capacities

Cabinet and drawer specifications

Side view

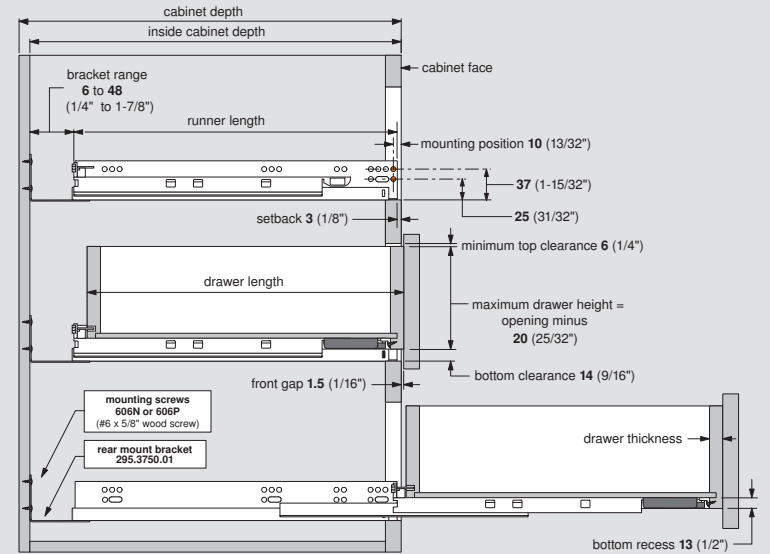

TANDEM plus BLUMOTION	Cabinet depth	Inside cabinet depth		Drawer length	Maximum drawer thickness	Runner length
		Maximum	Minimum			
563H5330B	610 (24")	599 (23-19/32")	557 (21-15/16")	533 (21")	16 (5/8")	548 (21-9/16")
563.5330B	610 (24")	—	557 (21-15/16")	533 (21")		548 (21-9/16")
563H4570B	533 (21")	522 (20-9/16")	480 (18-29/32")	457 (18")	16 (5/8")	471 (18-17/32")
563.4570B	533 (21")	—	480 (18-29/32")	457 (18")		471 (18-17/32")
563H3810B	457 (18")	446 (17-9/16")	404 (15-29/32")	381 (15")	16 (5/8")	395 (15-9/16")
563H3050B	381 (15")	370 (14-9/16")	328 (12-29/32")	305 (12")		319 (12-9/16")
563H2290B10	305 (12")	299 (11-25/32")	266 (10-15/32")	229 (9")	16 (5/8")	259 (10-3/16")

NOTE: For 563. series runners rear brackets and sockets cannot be used. Cabinet sides must be blocked-out flush with the inside of the frame.

T51.1901R	Locking device with side-to-side adjustment (right)	295.3750.01	Rear mounting bracket, non-handed
T51.1901L	Locking device with side-to-side adjustment (left)	295.3700.21	563H2290B10 rear bracket, non-handed
T51.1801R	Locking device (right)	295.3700.22	563H2290B10 rear bracket, non-handed
T51.1801L	Locking device (left)		
606N or 606P	#6 Wood screw (for mounting runner to cabinet side, rear brackets and locking devices)		



Runner mounting specifications

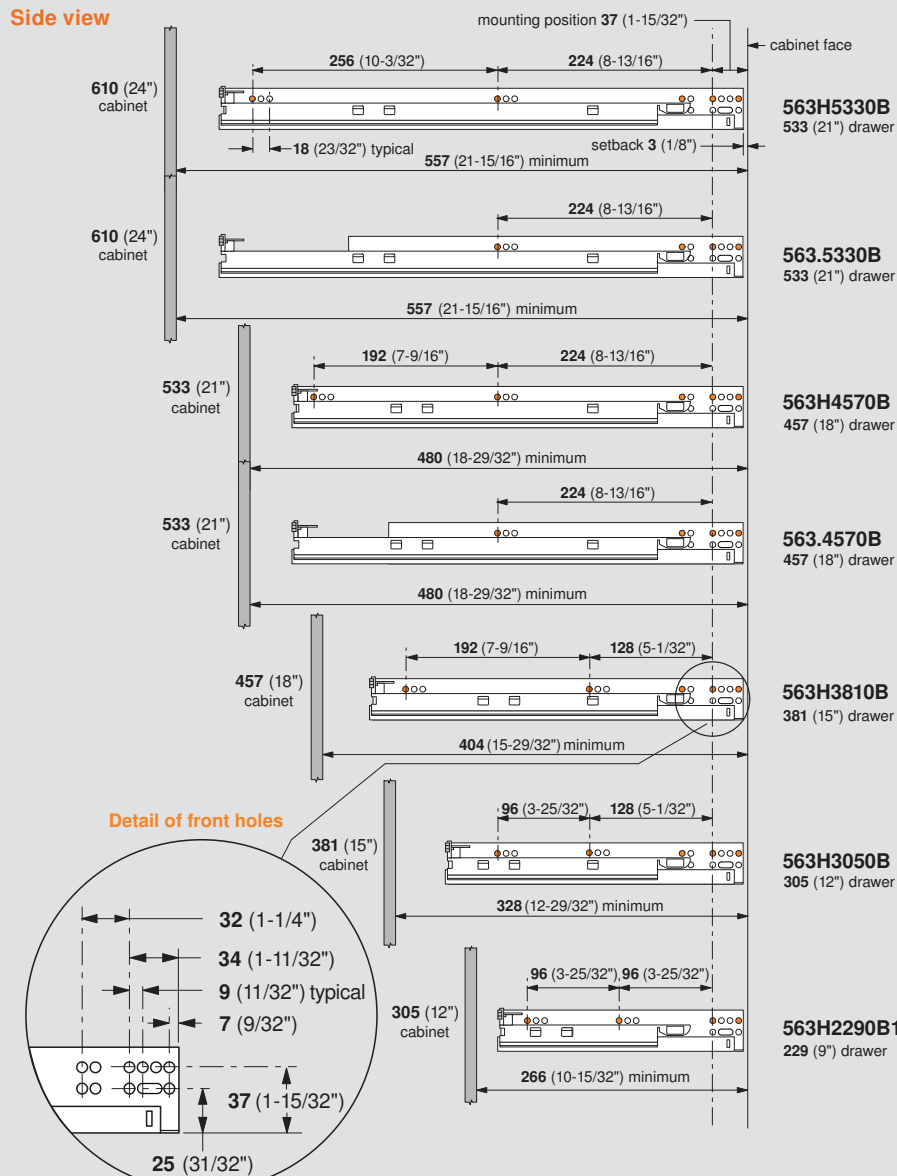

**NOTE:** Orange dots indicate screw locations required to meet specified load capacities

Cabinet and drawer specifications

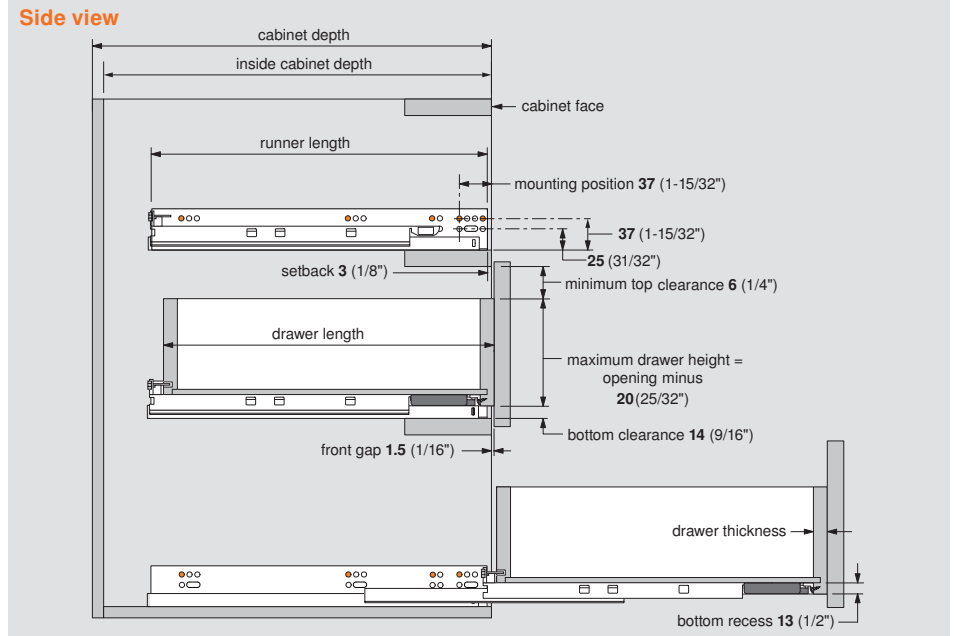

TANDEM plus BLUMOTION	Cabinet depth	Minimum inside cabinet depth	Drawer length	Maximum drawer thickness	Runner length
563H5330B	610 (24")	557 (21-15/16")	533 (21")	16 (5/8")	548 (21-9/16")
563.5330B	610 (24")	557 (21-15/16")	533 (21")		548 (21-9/16")
563H4570B	533 (21")	480 (18-29/32")	457 (18")		471 (18-17/32")
563.4570B	533 (21")	480 (18-29/32")	457 (18")		471 (18-17/32")
563H3810B	457 (18")	404 (15-29/32")	381 (15")		395 (15-9/16")
563H3050B	381 (15")	328 (12-29/32")	305 (12")		319 (12-9/16")
563H2290B10	305 (12")	266 (10-15/32")	229 (9")		259 (10-3/16")

T51.1901R	Locking device with side-to-side adjustment (right)
T51.1901L	Locking device with side-to-side adjustment (left)
T51.1801R	Locking device (right)
T51.1801L	Locking device (left)
606N or 606P	#6 Wood screw (for mounting runner to cabinet side, rear brackets and locking devices)
662.1150.HG	#6 System screw (for mounting runner to cabinet side)



Inset application

Face frame application – complete blackout

Side view

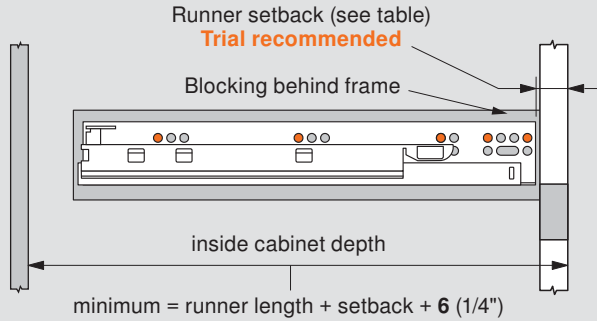

Face frame application – partial blackout

Side view

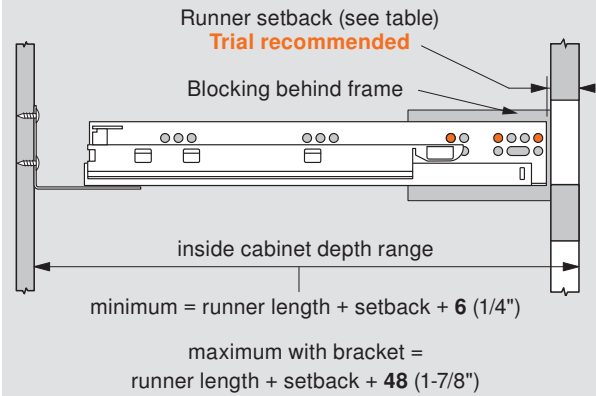

Panel application

Side view

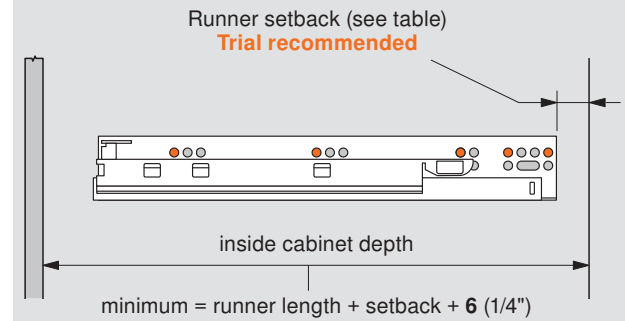

Setback information

Side view

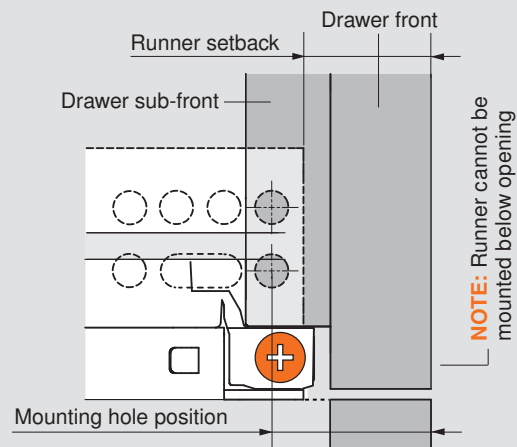

NOTE: For mounting hole position add 7 (9/32") to runner setback

Runner setback when using depth adjustable locking device (T51.1901.PS)



563/569 H/.		Runner setback		
Sub-front thickness	13 (1/2")	20 (25/32")	23 (29/32")	26 (1-1/32")
	16 (5/8")	23 (29/32")	26 (1-1/32")	29 (1-5/32")
	19 (3/4")	26 (1-1/32")	29 (1-5/32")	32 (1-1/4")
		16 (5/8")	19 (3/4")	22 (7/8")
		Drawer front thickness		
Calculating runner setback	563/569 H/.	Sub-front thickness + drawer front thickness minus 9 (11/32")		

- Setbacks in this table recess the face of the drawer front inside of the cabinet 1 (1/32")
- The depth adjustment can then be used to move the drawer front out to its desired position, 2.5 (3/32") out adjustment only

Runner setback when using all other locking devices



563/569 H/.		Runner setback		
Sub-front thickness	13 (1/2")	17.5 (11/16")	20.5 (13/16")	23.5 (15/16")
	16 (5/8")	20.5 (13/16")	23.5 (15/16")	26.5 (1-1/32")
	19 (3/4")	23.5 (15/16")	26.5 (1-1/32")	29.5 (1-5/32")
		16 (5/8")	19 (3/4")	22 (7/8")
		Drawer front thickness		
Calculating runner setback	563/569 H/.	Sub-front thickness + drawer front thickness minus 11.5 (7/16")		

- Setbacks in this table set the face of the drawer front flush with the face of the cabinet
- If a depth adjustable locking device is needed, please see the locking device and table above



Rear attachment options for face frame applications

Front view

**295.3750.01** Rear mounting bracket, non-handed

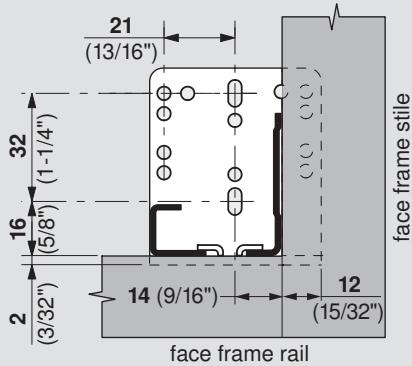

**295.3700.2x** For 563H2290B10, non-handed

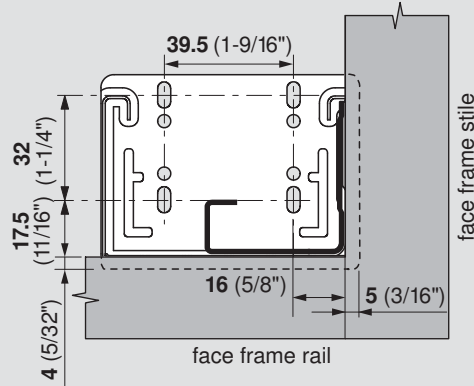

**295.6410** Plug-in socket, non-handed

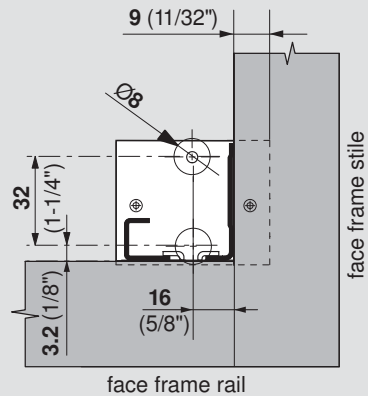

**295.6400** Screw-on socket, non-handed

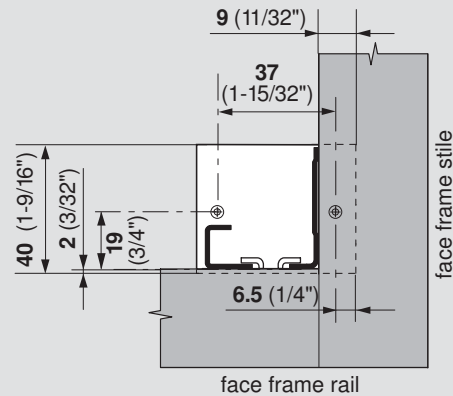

**NOTE:** Use at least three 606N or 606P installation screws for 295.3750.01 or 295.3700.2x

Millimeter to inch conversion chart

1	1.5	2	3	4	5	5.5	6	7	8	9	9.5	10	11	12	13	13.5	14	15	16	17	17.5	18	19	20	20.5	21	22	23	24	24.5	25.4
1/32	1/16	3/32	1/8	5/32	3/16	7/32	1/4	9/32	5/16	11/32	3/8	13/32	7/16	15/32	1/2	17/32	9/16	19/32	5/8	21/32	11/16	23/32	3/4	25/32	13/16	27/32	7/8	29/32	15/16	31/32	1

Depth adjustment specifications

Side view

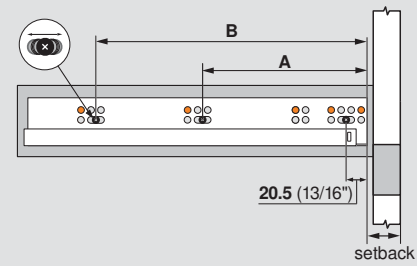

TANDEM plus BLUMOTION	A	B
563H5330B	244.5 (9-5/8")	500.5 (19-23/32")
563.5330B	244.5 (9-5/8")	—
563H4570B	244.5 (9-5/8")	436.5 (17-3/16")
563.4570B	244.5 (9-5/8")	—
563H3810B	148.5 (5-27/32")	340.5 (13-13/32")
563H3050B	148.5 (5-27/32")	244.5 (9-5/8")
563H2290B10	116.5 (4-19/32")	212.5 (8-3/8")

Mount each runner using at least two of the elongated holes. Install the drawer to check the position of the drawer front.

Remove the drawer, loosen screws and make adjustments if necessary,  $\pm 4.5$  (3/16"). Tighten the screws, verify the drawer front position and finish mounting the runners using the screw locations indicated by the orange dots.

Bottom mounting specifications

Top view

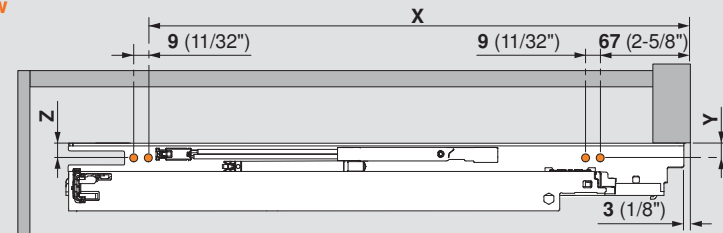

TANDEM plus BLUMOTION	Drawer length	Minimum inside cabinet depth	X	Y	Z
563H5330B	533 (21")	557 (21-15/16")	448 (17-5/8")	12 (15/32")	19 (3/4")
563.5330B	533 (21")	557 (21-15/16")	358 (14-3/32")	12 (15/32")	19 (3/4")
563H4570B	457 (18")	480 (18-29/32")	378 (14-7/8")	12 (15/32")	19 (3/4")
563.4570B	457 (18")	480 (18-29/32")	358 (14-3/32")	12 (15/32")	19 (3/4")
563H3810B	381 (15")	404 (15-29/32")	319 (12-9/16")	12 (15/32")	19 (3/4")