

1

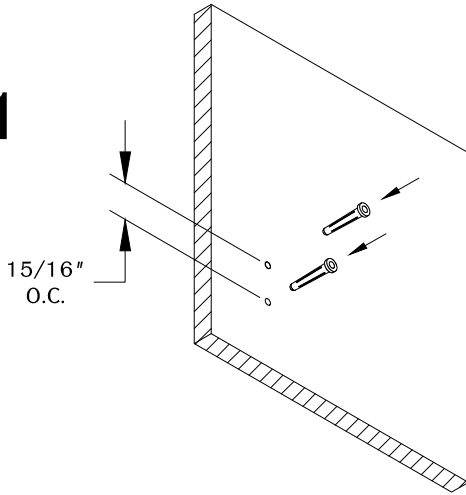

2

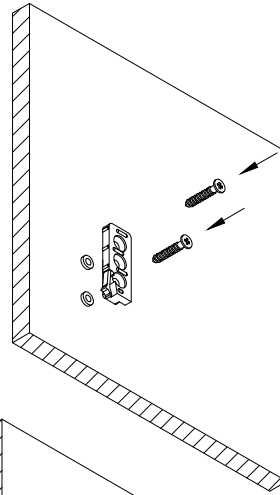

3

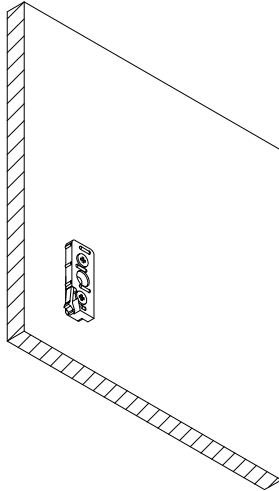

4

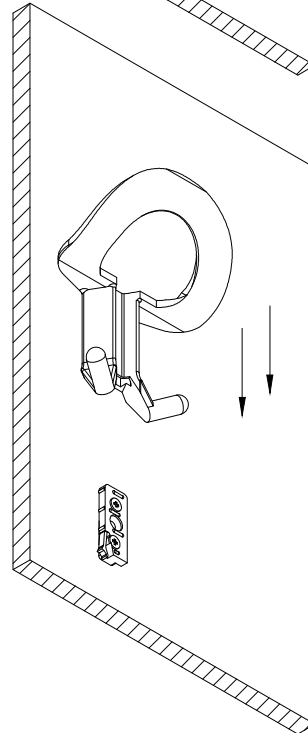

5

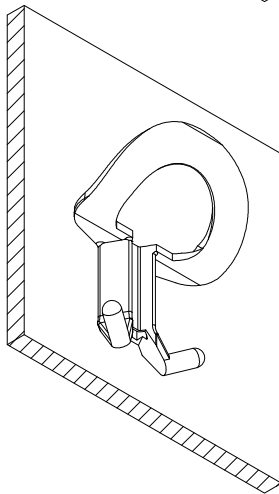

15 LBS. MAX WEIGHT.

NOTE:

ALL DIMENSIONS HAVE A $\pm 1/32$ " TOLERANCE UNLESS OTHERWISE SPECIFIED. WE DON'T RECOMMEND DRILLING OR CUTTING ANY HOLES BEFORE RECEIVING A PRODUCT OR A PRODUCT SAMPLE.

TABLE OF CONTENTS:

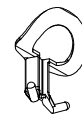

.....1 X CH1



.....1 X Mounting Bracket



.....2 X 1" Wood Screw



.....2 X Screw Anchor
part# HK-Anchor
(Optional for 40 lbs weight capacity)