

**E-GLIDE
LADDER
HARDWARE**

EG.300 Series



Instruction Manual for Installing E-Glide Ladder Hardware

Hardware Included:

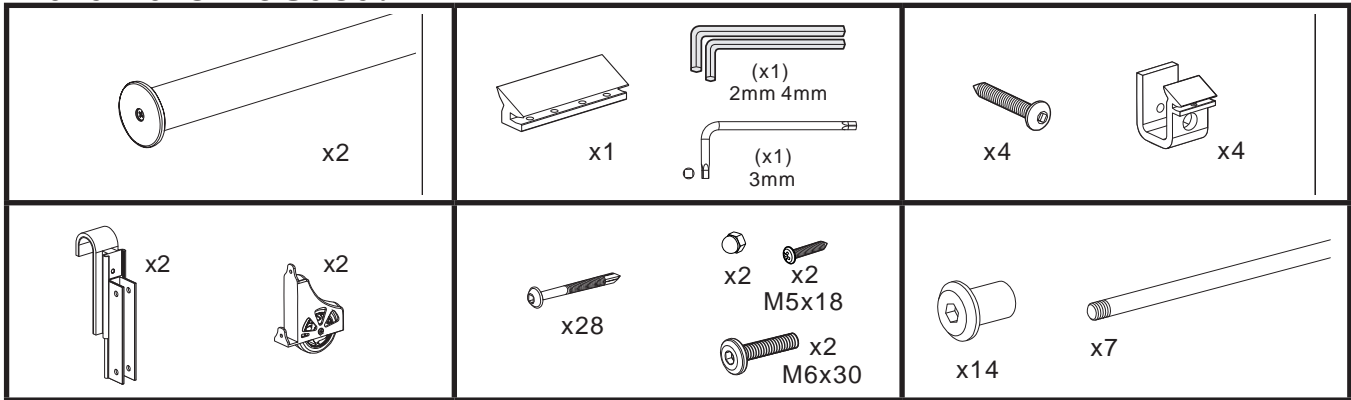

Installation Tools Needed:

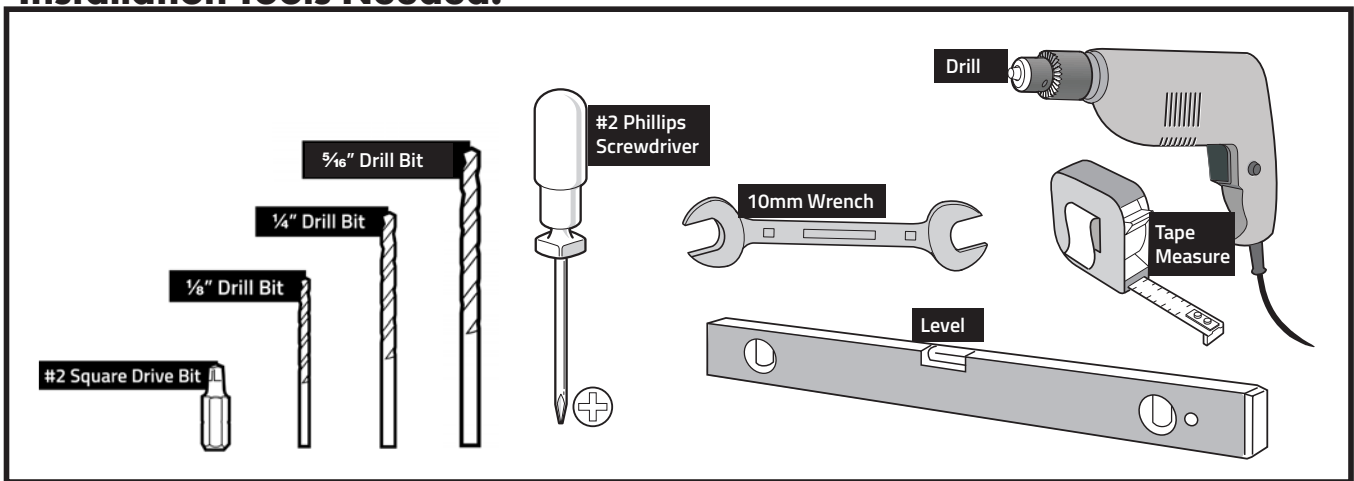

Step 1: Rail Installation

Special application notes:

- Do not mount rail brackets directly onto a drywall surface. Always mount these brackets to solid wood, predrilling the holes is advisable to avoid splitting the wood.
- Clearance requirements:
 - Ladder in the stored position (close to the wall/cabinet/bookshelf). Leave at least 2 1/2" of clearance between the top of the rail and the ceiling, crown molding or other overhanging protrusions (figure 1).
 - Ladder in the climbing position, a minimum 1" clearance between the top of the rail and any upper cabinet doors is required to be able to open these doors (figure 2).

Figure 1

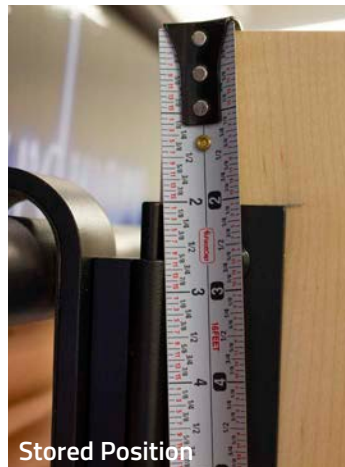
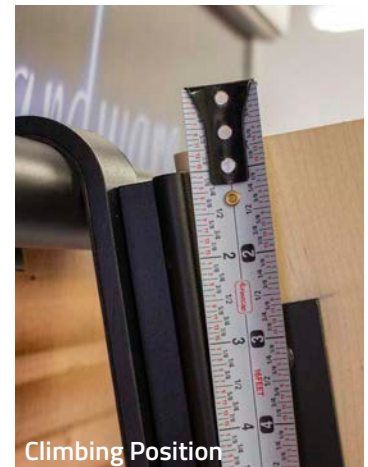

Figure 2



- Rail height determination: Distance from the floor to the location on the header board where the screw for the rail bracket will be fastened.
 - For the **92"** ladder = **88 1/4" to 89 1/4"**
 - For the **107"** ladder = **103 1/4" to 104 1/4"**

2. Using a good quality level, lightly score a level pencil line on the headerboard where the bracket screw will be fastened into.
3. To splice rails together using the E-Glide splice kit (EG.41) complete the following steps:
 - Slide the splice half-way into one of the rails and tighten down the 2 set screws (figure 3, image 1)
 - Slide the other rail over the splice and tighten those set screws (figure 3, image 2)

Figure 3

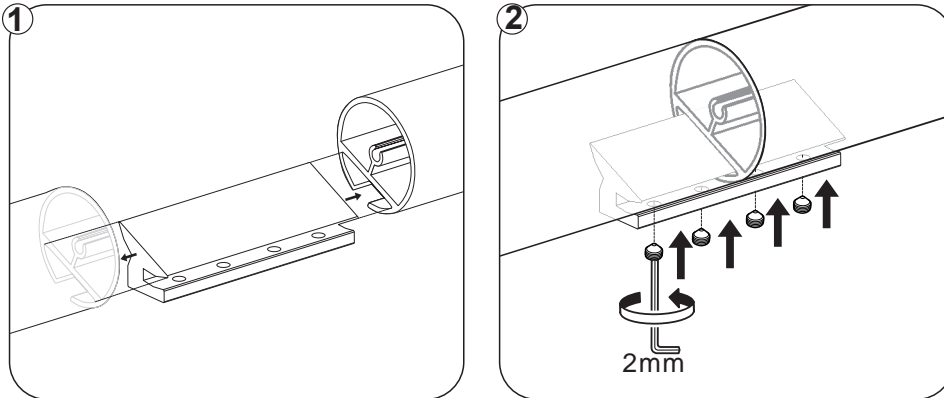

4. Slide all the brackets onto the rail, see the recommended spacing below (figure 4). Leave the brackets loose on the rail at this point.
5. Starting at one end, secure each bracket with the supplied screws to the wood header along the line that was scored as described in step 2 of this section.
6. After all the brackets are screwed to the wood header and the rail is in the intended position, tighten the small set screw on front of each bracket to the rail (figure 4).

Figure 4

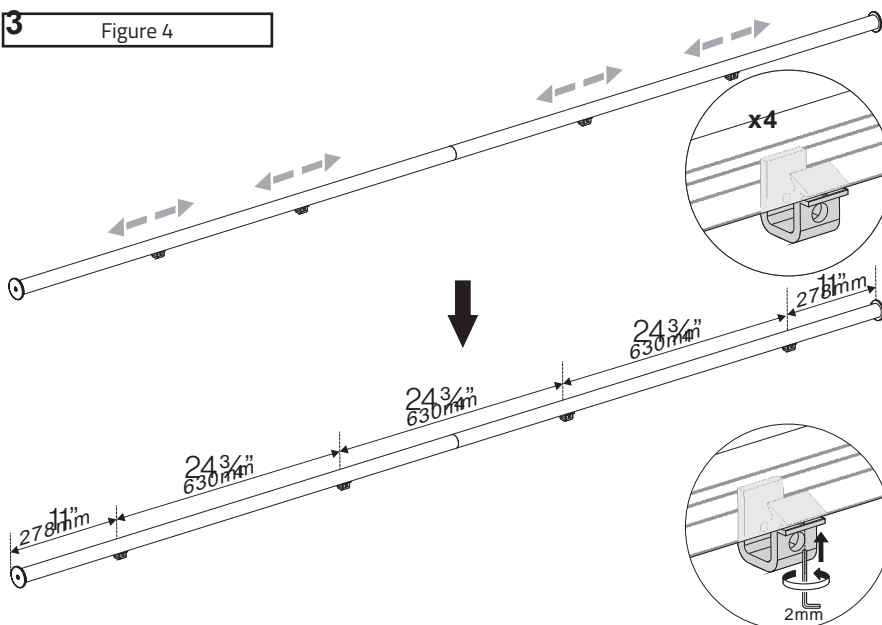

Step 2: Ladder Assembly (if applicable)

If the ladder is Unfinished:

It is recommended that the ladder side rails and steps are sanded slightly with a 220-grit sandpaper just prior to applying the finish (stain, paint, clear coat sealer, etc.).

We recommend finishing the ladder before assembly. Before applying the finish, protect the insides of the dados and the ends of the steps with a quality painter's tape. This will prevent the finish from hindering a good, strong glue bond between the steps and the side rails (figure 5).

Figure 5



1. Stand on edge one of the ladder side rails on a flat surface, dados facing away from you, and the front edge of the ladder facing up.
2. Draw a small line on the top of each step $\frac{5}{8}$ " in from the front edge (on both ends) in order to line up each step consistently into each dado throughout the entire length of the ladder (figure 6).

Figure 6



3. Apply a thin film of quality woodworker's glue to the end of the step (only the portion that will be buried in the dado) and also in the dado (figure 7).
4. Align the mark on the top of the step to the front edge of the ladder side rail (figure 8).

Figure 7



Figure 8



5. Using the supplied 1 ¼" washer-head screws, secure the step to the side rail through the predrilled holes on the side rails (for aesthetic purposes, don't over tighten the screws which can crack the wood around the screw head). Assemble the remaining steps in the same manner (*figure 9*).
6. Once all the steps are assembled onto one of the side rails, position the side rail on its side with the steps pointing up.

Figure 9



7. Apply a thin film of glue on the ends of each step and in the dado of the other rail.
8. Properly align each step in the dado with the mark on the surface of the step (*figure 10*). Use the supplied 1 ¼" washer-head screws to complete the fastening of the steps into the side rails (*figure 11*).

Figure 10



Figure 11

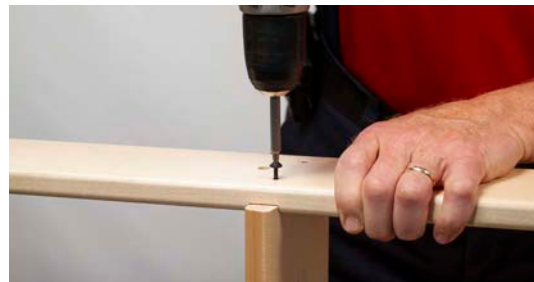

9. Installation of the step support rods:
 - Thread the support rod into one of the nut caps, leave half of the thread on the rod showing.
 - Slide the support rod through each hole in the ladder side rails, install the other nut cap.
 - Using two 5mm Allen wrenches, tighten each side simultaneously so that there are equal amounts of thread on each side of the rod (*figures 12 & 13*).

Figure 12



Figure 13



Step 3 Ladder Hardware Installation

Top Ladder Hardware

1. On the outside of each ladder side rail, measure down 2" from the top of the ladder and draw a 1/2" line from the back edge of the side rail (*figure 14 - see the next page for complete measurements*).
2. Align the top edge of the Upper Hook Assembly with the line. Clamp or hold the hardware in place to drill the through holes in the side rail (*figure 15*).

Figure 14

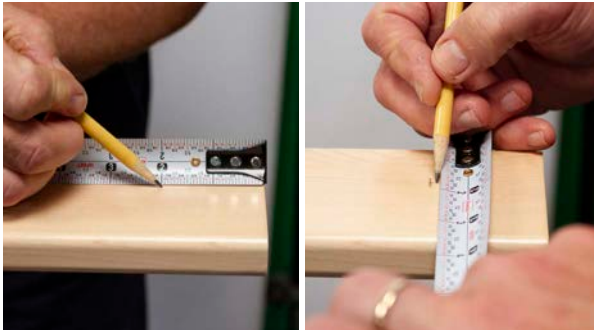

Figure 15



3. Using a 5/16" drill bit, drill out the holes for the nut cap/threaded rod on the sides of the ladder.

Recommended procedure for this:

- Using the holes in the Upper Hook Assembly as a drill guide, drill a 5/16" hole halfway through the thickness of the ladder slide rail (1).
- Drill the same hole on the opposite side of the Upper Hook Assembly, producing a 5/16" through hole in the ladder side rail (2).
- Follow this same procedure for all four through holes and complete the assembly by securing the top roller guide with the supplied nut caps and threaded rod (3 - 5).

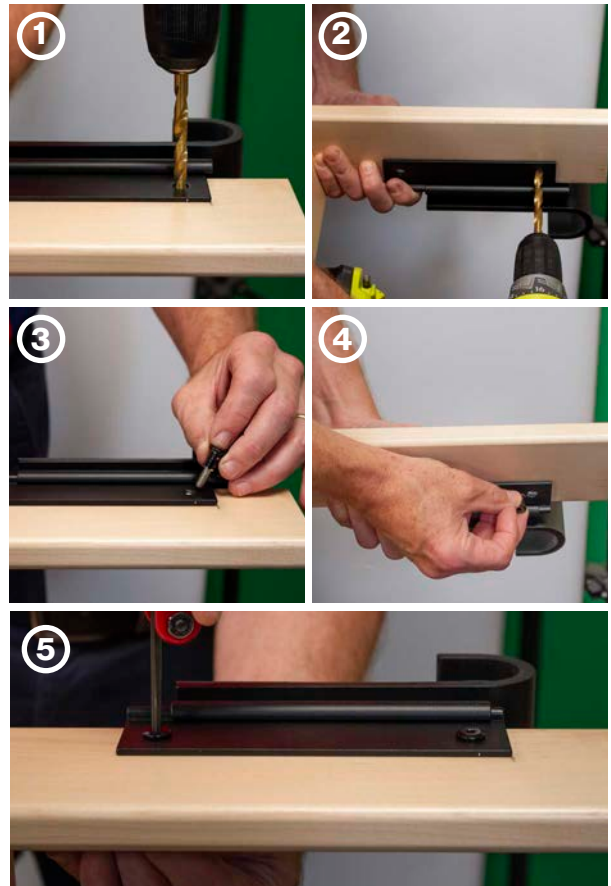

TOP LADDER HARDWARE MEASUREMENTS

2" down from top of ladder

Fastener Hole Placement

- 7/8" in from back edge of the side rail
- 2 5/8" and 7 7/8" down from the top of the ladder to center of hole for the fastener

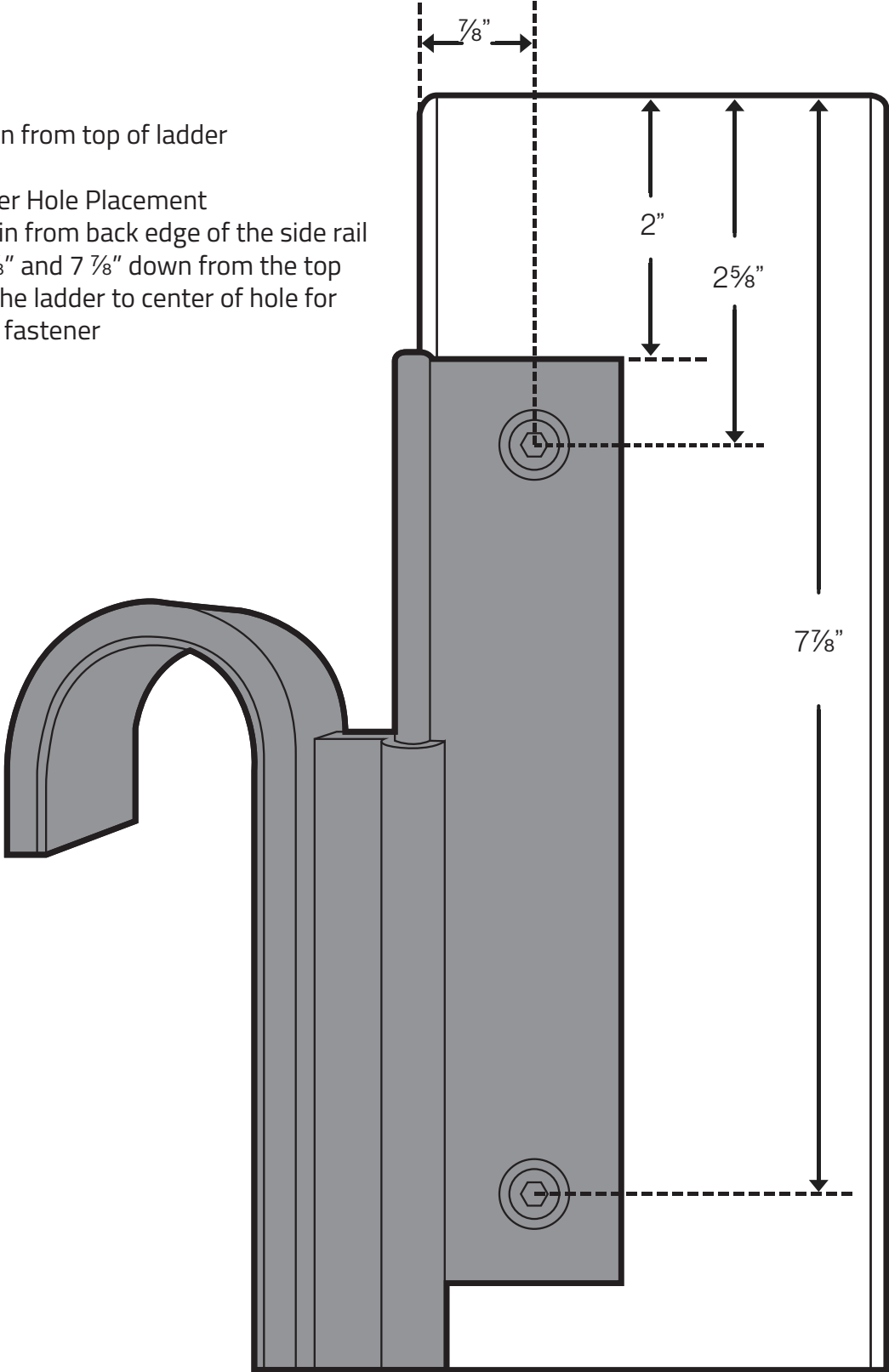

Bottom Ladder Hardware

1. Mark a line on the bottom of each side rail $1\frac{1}{2}$ " in from the front edge (*figure 16*).
2. Line up the Bottom Wheel Housing to the line drawn on the bottom of the side rail of the ladder using the "U" bracket portion of the housing. Verify that the bracket is flush with the bottom of the ladder. Because of the 12-degree angle of the bottom of the ladder this will align the housing diagonally across the ladder side rail (*figure 17*).

Figure 16

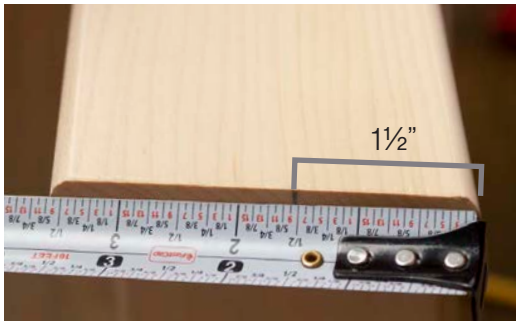

Figure 17



3. Using a $\frac{1}{8}$ " drill bit, predrill the hole for the Philips-drive pan-head $\frac{3}{4}$ " long screw and secure the Bottom Wheel Housing to the inside of the ladder side rail (*see below*).



Figure 18

4. Using a $\frac{1}{4}$ " drill bit and the top fastener hole in the Bottom Wheel Housing as a guide, drill a through hole in the ladder side rail (*figure 18*).
5. Use the nut cap/threaded rod and the acorn nut to fasten the top of the Bottom Wheel Housing to the ladder side rail (using a 4 mm Allen wrench and a 10 mm open end wrench) (*see the three images below*).



E-GLIDE HARDWARE MEASUREMENTS



Upper Hook Measurements

- Length - 4 1/4"
- Width - 1 3/4"
- Height - 6 1/2"

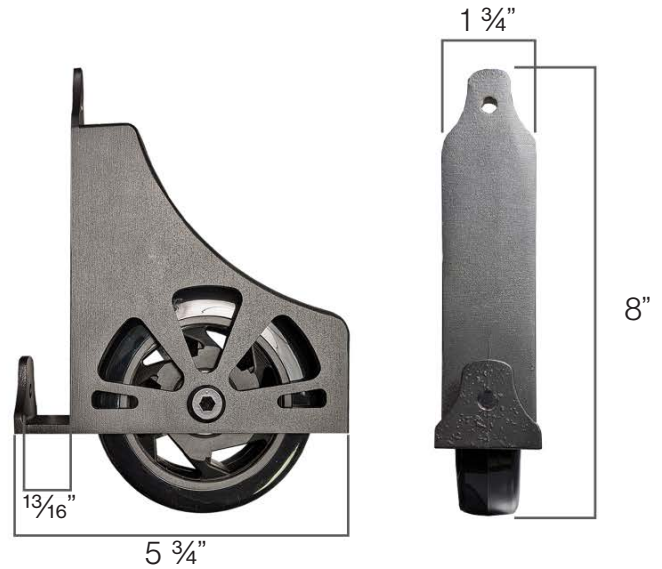

Bottom Wheel Measurements

- Length - 5 3/4"
- Width - 1 3/4"
- Height - 8"



Splice Measurements

- Length - 2 5/8"
- Width - 9/16"
- Height - 5/8"



Rail Measurements

- Length - 48"
- Diameter - 1/4"

End Stop

- Width - 1 5/16"
- Diameter - 1/8"

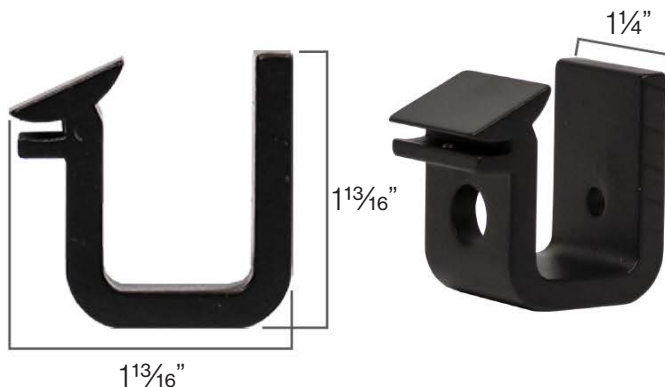

Upper Hook Measurements

- Height - 1 13/16"
- Width - 1 13/16"
- Depth - 1 1/4"

E-Glide Ladder Dimensional Specification

Notes:

Two Lengths

- 92" OA length
- 107" OA length

Material: Select or Better, Flat cut

Sanded to 180 grit

All 4 edges of the side rails, steps, and top of the side rails shall have a 1/4" radius round over.

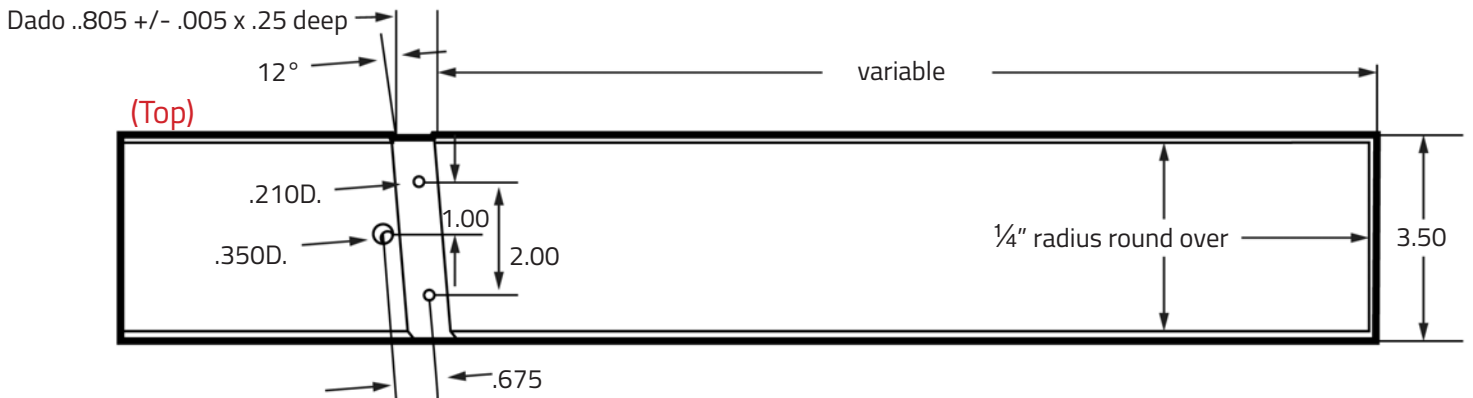
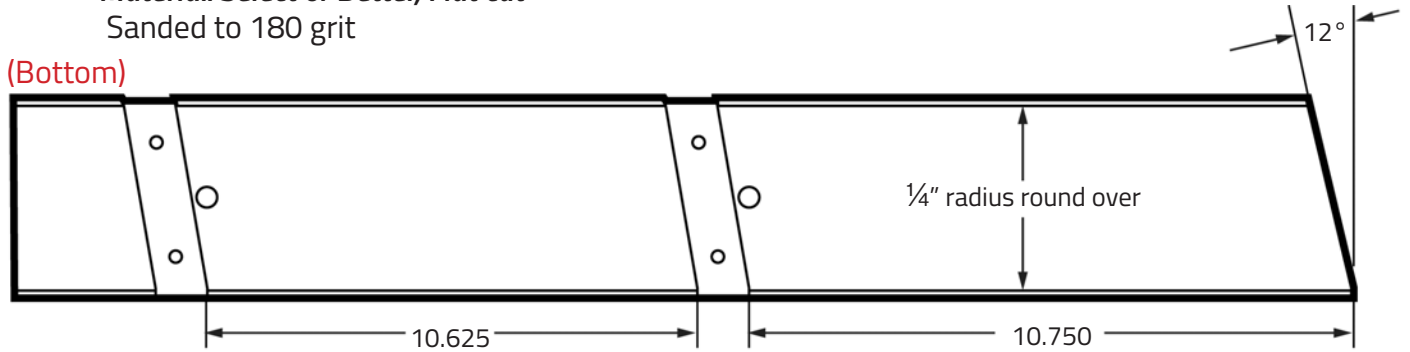

Side Rail Material thickness .805 +/- .010

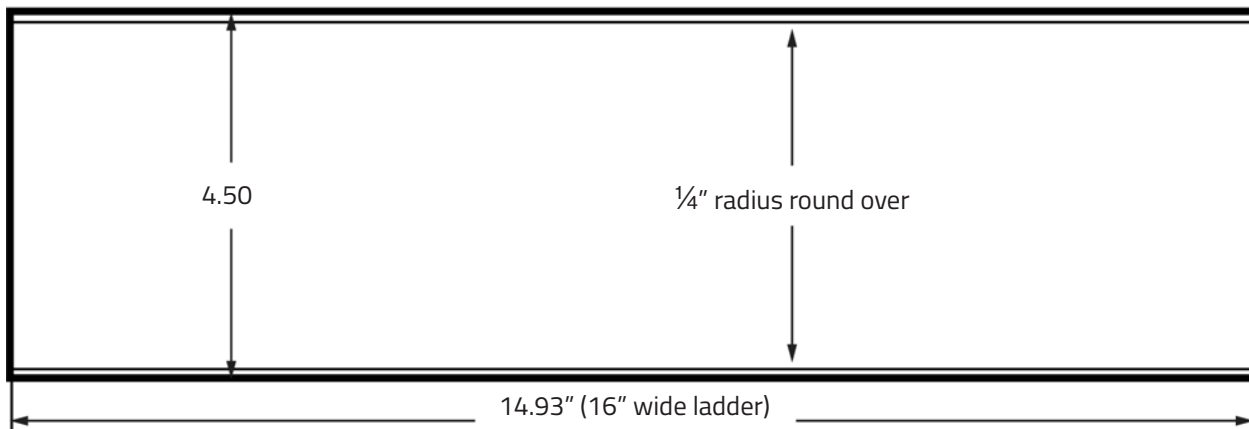
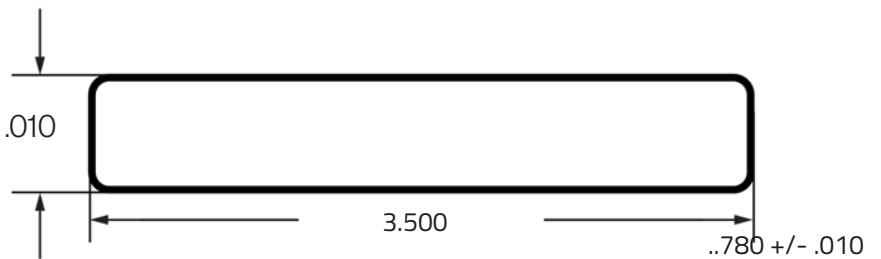

Application Photos of E-Glide Ladders



Also available from CSH:



Mini Barn Door Hardware





InvisiDoors



Rolling Barn Door Hardware



 1170 Wauwatosa Rd.
Cedarburg, WI 53012

 (262) 365-7960

 cshardware.com