



DYNAPRO



**G\* GRASS®**

## DYNAPRO SLIDE SYSTEM

Synchronized full extension concealed undermount slides.  
Precision in movement, design, and comfort.



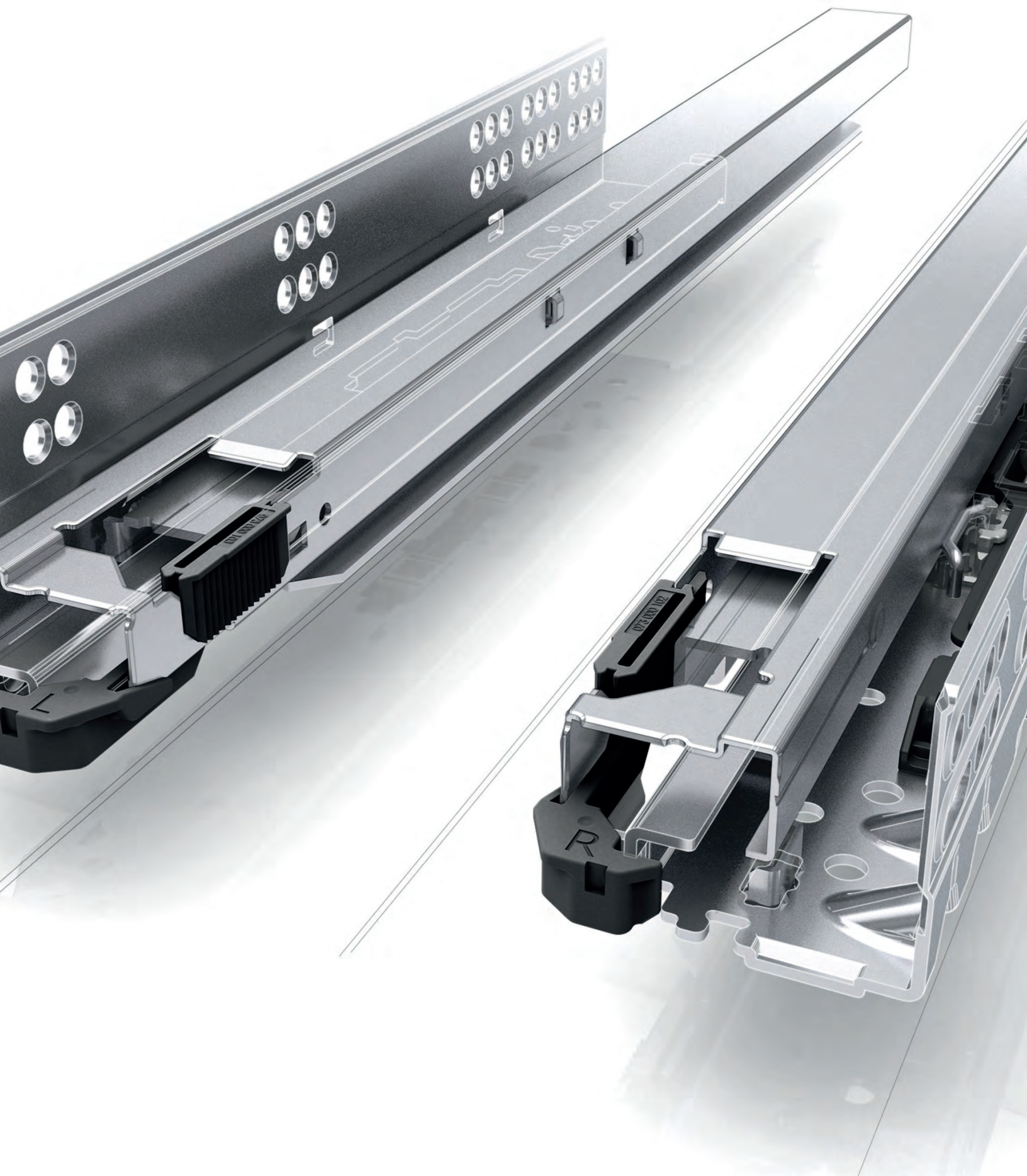





To create a product innovation is one thing.  
To establish it is quite another. To successfully  
develop product innovations – that is our business.  
Dynapro proves that.

**A slight pull and a gentle push.**

With a drawer as technically advanced as Dynapro, you will find many enhanced features. The ease in which Dynapro pulls open is smooth and comfortable. But Dynapro's closing action is what makes an impression. Whether it is the standard soft-closing action or a mechanically enhanced soft-closing action, Dynapro drawers pull closed with a smooth, gentle motion that is nothing short of amazing.



## DYNAPRO SLIDE SYSTEM

Efficient. Effective. Concealed.

Dynapro undermount slides for wood drawers and Vionaro drawers combine intelligent features plus superb gliding action for today's traditional and contemporary cabinetry.



**Synchronization achieves smooth operation without a sound.**

In contrast to conventional undermount slide systems, Dynapro features a synchronization mechanism. The mechanical synchronization of each individual slide ensures enhanced comfort and movement without annoying sounds or resistance. The operating function of Dynapro remains unchanged even when moving heavy loads of up to 132 lb. Abrasion-resistant nylon rollers ensure smooth and even operation. Available for drawer material ranging from 12.7mm (1/2") to 19mm (3/4").



**4D adjustment for perfect alignment: height, side, depth, and tilt adjustment**

Dynapro undermount slides offer a variety of Front Locking Devices to provide two, three, or four-dimensional adjustments. The drawer can be adjusted side-to-side, height, depth, and tilt. With the option of 4-dimensional adjustment, precise alignment of the drawer fronts is extremely easy. All of the adjustments are simple operations and easily performed without the use of tools. With the Dynapro adjustments, you can achieve perfect alignment.



**The Vionaro drawer combined with Dynapro is a perfect match for a new drawer system.**



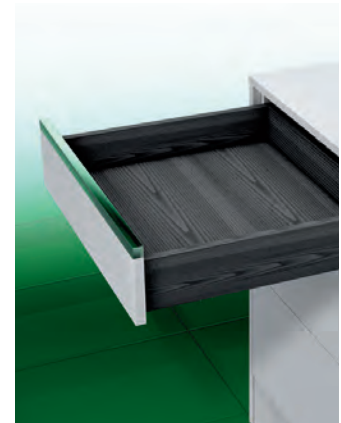

With the introduction of the Vionaro drawer system, Dynapro becomes a multifunctional system for wood drawers and metal drawers. The Vionaro slim line metal drawer sides rest on top of the Dynapro concealed slide system offering the next step in drawer technology. Two drawer types using the same concealed undermount slide with outstanding running performance, a high load carrying capacity, and a low pull-out force.



**Four options for closing comfort.**

Dynapro features a liquid damper Soft-close technology for an exceptionally smooth closing action. Soft-close gently slows the drawers and pulls them to the fully closed position. Tipmatic is a touch activated mechanism that makes it possible to open drawers with a gentle push on the drawer front. Tipmatic Soft-close has the same opening action with the added benefit of the soft-closing action. The Sensomatic electronic touch-to-open system makes it possible to create large, handle-free drawers that open with a gentle push on the front and the closing is just as smooth with another gentle push.



	Description	Adjustment	Page
	<b>Features &amp; Benefits</b>		6
	<b>Technical Information</b>		8
	<b>Dynapro 16 (2D)</b> <ul style="list-style-type: none"> <li>Optional 3-Dimensional Adjustment</li> <li>Face frame or frameless</li> <li>Integrated Soft-close, full extension</li> <li>For 16mm (5/8") material</li> </ul>	<b>Front locking device selection provides:</b> <ul style="list-style-type: none"> <li>Height adjustment (max +3.5mm)</li> <li>Side adjustment (max ±1.5mm)</li> <li>Depth adjustment (max 3.0mm forward)</li> </ul>	14
	<b>Dynapro 16 (3D)</b> <ul style="list-style-type: none"> <li>Optional 4-Dimensional Adjustment</li> <li>Face frame or frameless</li> <li>With tilt adjustment</li> <li>Integrated Soft-close, full extension</li> <li>For 16mm (5/8") material</li> </ul>	<b>Front locking device selection provides:</b> <ul style="list-style-type: none"> <li>Height adjustment (max +3.5mm)</li> <li>Side adjustment (max ±1.5mm)</li> <li>Tilt adjustment (max ±4.0mm)</li> <li>Depth adjustment (max 3.0mm forward)</li> </ul>	18
	<b>Dynapro 16 (3D) Heavy Duty</b> <ul style="list-style-type: none"> <li>Optional 4-Dimensional Adjustment</li> <li>Face frame or frameless</li> <li>With tilt adjustment</li> <li>Extended lengths</li> <li>Integrated Soft-close, full extension</li> <li>For 16mm (5/8") material</li> </ul>	<b>Front locking device selection provides:</b> <ul style="list-style-type: none"> <li>Height adjustment (max +3.5mm)</li> <li>Side adjustment (max ±1.5mm)</li> <li>Tilt adjustment (max ±4.0mm)</li> <li>Depth adjustment (max 3.0mm forward)</li> </ul>	22
	<b>Dynapro 16 Tipmatic</b> <ul style="list-style-type: none"> <li>Integrated Tipmatic</li> <li>For drawers without pulls</li> <li>Full extension</li> </ul>	<b>Front locking device selection provides:</b> <ul style="list-style-type: none"> <li>Height adjustment (max +3.5mm)</li> </ul>	24
	<b>Dynapro 16 Tipmatic Soft-close</b> <ul style="list-style-type: none"> <li>For 16mm (5/8") material</li> <li>Tool-free assembly</li> <li>Works with all Dynapro types</li> </ul>		26
	<b>Dynapro Base Panel and Pull Out Shelf</b> <ul style="list-style-type: none"> <li>Frameless, for 16mm (5/8") material</li> <li>Integrated Soft-close, full extension</li> </ul>	<b>Front locking device selection provides:</b> <ul style="list-style-type: none"> <li>Height adjustment (max +3.5mm)</li> </ul>	28
	<b>Dynapro 19 (2D)</b> <ul style="list-style-type: none"> <li>Optional 3-Dimensional Adjustment</li> <li>Face frame or frameless</li> <li>Integrated Soft-close, full extension</li> <li>For 19mm (3/4") material</li> </ul>	<b>Front locking device selection provides:</b> <ul style="list-style-type: none"> <li>Height adjustment (max +3.5mm)</li> <li>Side adjustment (max ±1.5mm)</li> <li>Depth adjustment (max 3.0mm forward)</li> </ul>	30
	<b>Dynapro 19 (3D)</b> <ul style="list-style-type: none"> <li>Optional 4-Dimensional Adjustment</li> <li>Face frame or frameless</li> <li>With tilt adjustment</li> <li>Integrated Soft-close, full extension</li> <li>For 19mm (3/4") material</li> </ul>	<b>Front locking device selection provides:</b> <ul style="list-style-type: none"> <li>Height adjustment (max +3.5mm)</li> <li>Side adjustment (max ±1.5mm)</li> <li>Tilt adjustment (max ±4.0mm)</li> <li>Depth adjustment (max 3.0mm forward)</li> </ul>	32
	<b>Dynapro 19 (3D) Heavy Duty</b> <ul style="list-style-type: none"> <li>Optional 4-Dimensional Adjustment</li> <li>Face frame or frameless</li> <li>3-dimensional with tilt adjustment</li> <li>Extended lengths</li> <li>Integrated Soft-close, full extension</li> <li>For 19mm (3/4") material</li> </ul>	<b>Front locking device selection provides:</b> <ul style="list-style-type: none"> <li>Height adjustment (max +3.5mm)</li> <li>Side adjustment (max ±1.5mm)</li> <li>Tilt adjustment (max ±4.0mm)</li> <li>Depth adjustment (max 3.0mm forward)</li> </ul>	38
	<b>Dynapro 19 Tipmatic Soft-close</b> <ul style="list-style-type: none"> <li>For 19mm (3/4") material</li> <li>Tool-free assembly</li> <li>Works with all Dynapro types</li> </ul>		40
	<b>Accessories</b>		42
	<b>Sensomatic</b> <ul style="list-style-type: none"> <li>Automatic soft touch drawer opening</li> <li>Various mounting options</li> </ul>	<b>Adjustable opening strength</b>	44

# Features and Benefits

## Dynapro

### Features



- Synchronization for smooth, silent operation
- Slide is concealed to give a full view of finely crafted drawers
- Self-latching front locking devices have comfortable release levers for drawer removal
- For drawer material thickness: 12.7mm (1/2") to 19mm (3/4")
- Support roller for uniform drawer front height
- Fully enclosed liquid damper softly glides drawers to a stop
- 2D, 3D, and 4D adjustment - height, side, depth, and tilt - is simple, tool-free, and easily accessible
- Easy to open with a low pull-out force
- For drawers up to 48" wide
- Wide drawer member provides stability between cabinet and drawer member
- Meet and exceeds ANSI/BHMA A156.9 standard, Grade 1

### Multiple cleats

connect immediately with front locking device at installation for maximum connection between the drawer slide and front locking device.



Dynapro's synchronization allows drawers to move quietly and without any resistance. Even with a load capacity of up to 132 lb the running performance remains unchanged.



## Features

- Wear resistant nylon rollers ensure quiet and precise running characteristics
- Synchronized full extension
- Face frame and frameless applications
- 100 lb dynamic load for Dynapro Standard
- 110 lb dynamic load for Dynapro Extended lengths
- 132 lb dynamic load for Dynapro Heavy Duty
- Minimal drawer front gap using adjustable front locking device
- Extended lengths for 24", 27", and 30" drawers

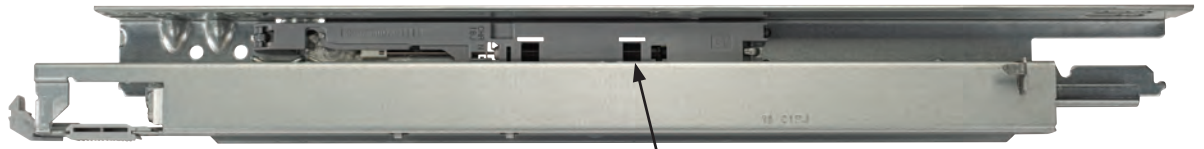

**Enclosed liquid damper**  
offers the latest closing technology.

**Abrasion resistant nylon rollers**  
ensure smooth and even operation.

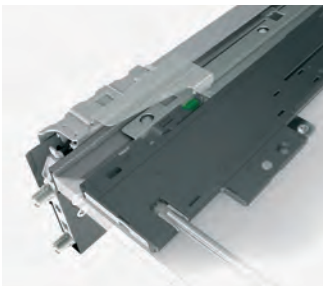
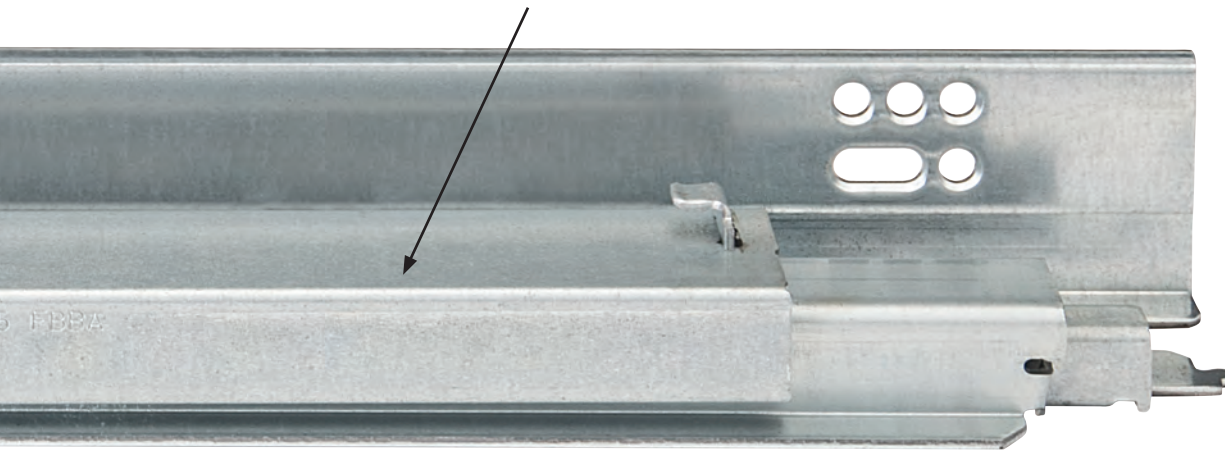

**Tipmatic Soft-close**  
for handle-free drawers

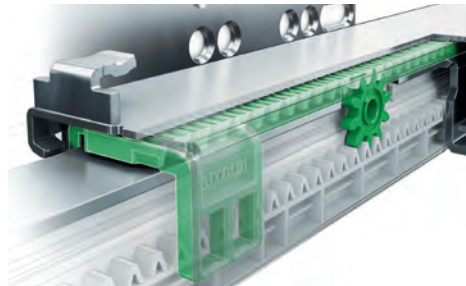

**Synchronization**  
for smooth, silent operation, excellent  
running performance

# Technical Information

## Dynapro

### 2D and 3D Front Locking Device with Height, Side, and Depth Adjustment

#### 3D Locking Devices



- Provides 2D or 3D adjustment for drawers
- For all drawer applications up to 48" in width
- Minimum inside drawer width 150mm (5 7/8")
- Lightweight, high strength material
- Height adjustment range: +3.5mm
- Side adjustment range: ±1.5mm
- Depth adjustment range: +3.0mm forward adjustment (3D version only)

Pre-drilling recommended Ø2.5mm (3/32")  
Patent Pending

#### 2D Locking Devices

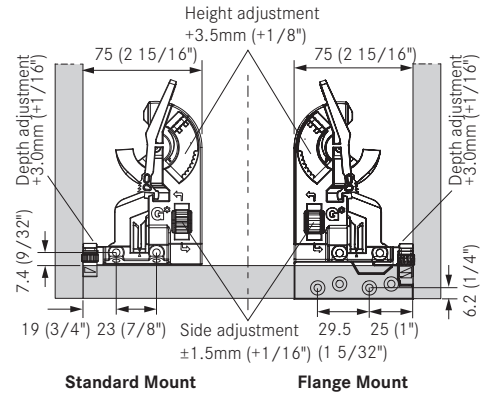

### Front Locking Device with Height and Side Adjustment

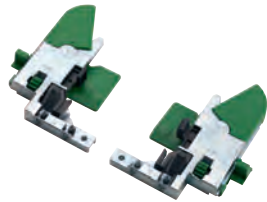

- Provides 2D adjustment for drawers
- For all drawer applications up to 48" in width
- Minimum inside drawer width 180mm (7 3/32")
- Height adjustment range: +3.5mm
- Side adjustment range: max ±1.5mm

Pre-drilling recommended Ø2.5mm (3/32")

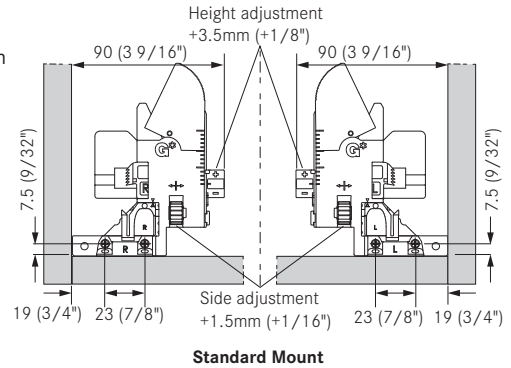

### Narrow Front Locking Device with Height Adjustment

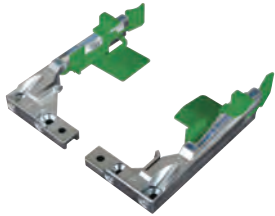

- Provides height adjustment for drawers
- For all narrow drawer applications
- Minimum inside drawer width 95mm (3 3/4")
- Height adjustment range: +3.5mm

Pre-drilling recommended Ø2.5mm (3/32")

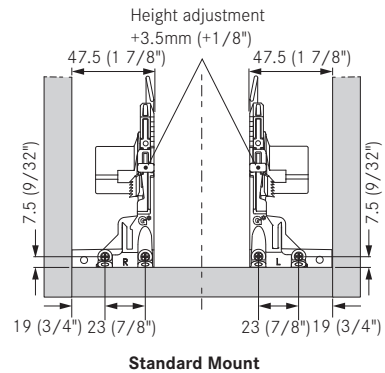

### Eco Front Locking Device with Height Adjustment



- Provides height adjustment for drawers
- For all drawer applications up to 48" in width
- Minimum inside drawer width 150mm (5 7/8")
- Height adjustment range: +3.5mm

Pre-drilling recommended Ø2.5mm (3/32")

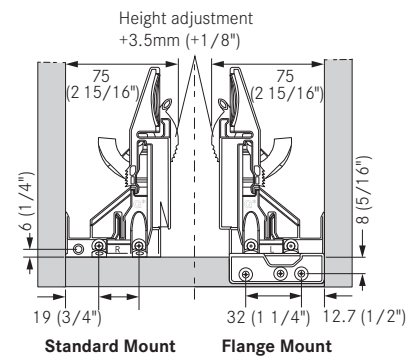



### Tilt Adjustment Adapter



- Provides tilt adjustment for Dynapro 3D, Dynapro heavy duty 3D, and Dynapro extended lengths 3D
- Tilt adjustment range: +4mm (5/32")
- For frameless or face frame applications

Pre-drilling recommended  $\varnothing 2.5\text{mm}$  (3/32")

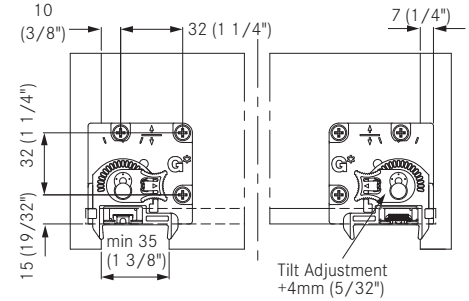

### Rear Mounting Brackets for Face Frame Applications

#### Rear Mounting Bracket for 12" - 21" Slides



- For 12" - 21" drawers
- For face frame application

Pre-drilling recommended  $\varnothing 2.5\text{mm}$  (3/32")

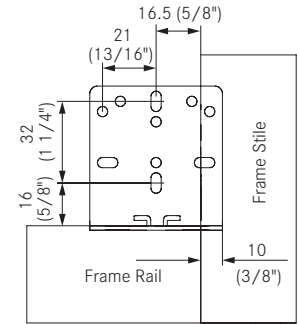

#### Narrow Rear Mounting Bracket for 12" - 21" Slides



- For 12" - 21" drawers
- For face frame application with narrow recess of side panel

Pre-drilling recommended  $\varnothing 2.5\text{mm}$  (3/32")

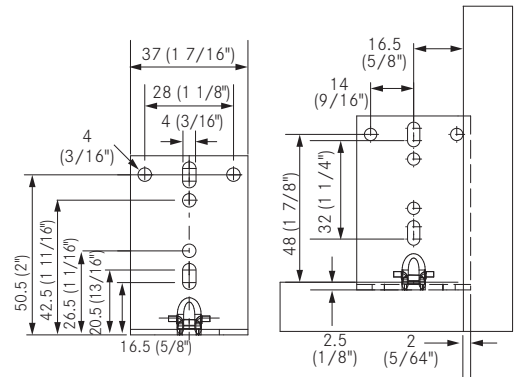

### Rear Mounting Socket for 9" Slides



- For 9" drawer
- For face frame application
- For installation depth min 273mm (10 3/4") to 352mm (13 7/8")

Pre-drilling recommended  $\varnothing 2.5\text{mm}$  (3/32")

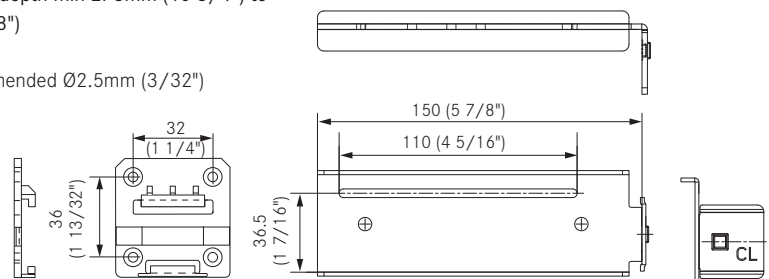

# Technical Information

## Inset drawer applications



- For inset drawer application with subfronts
- For face frame and frameless applications
- Use corresponding charts based on front locking device to determine slide setback

### IMPORTANT

To determine the correct application Grass strongly recommends a trial mounting for all slides.

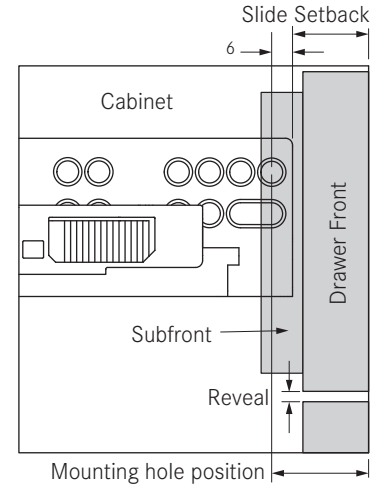

### Face Frame Inset Drawer with Partial Blockout      Frameless Inset Drawer with Full Blockout

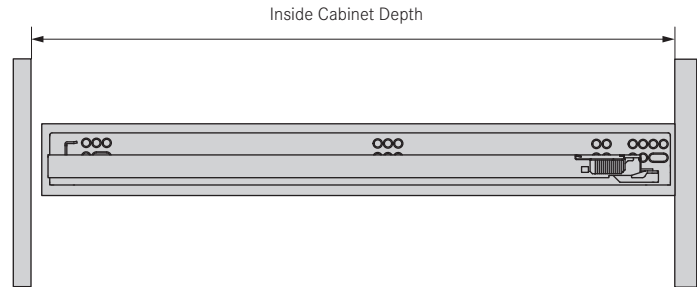
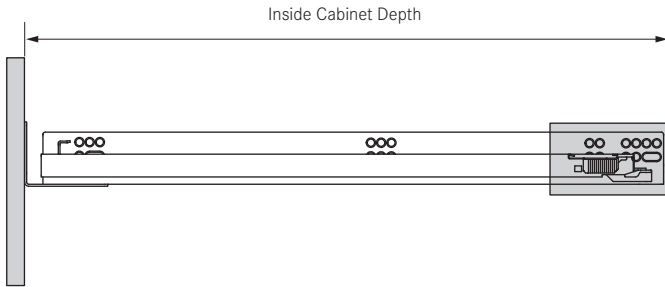

### Slide Setback for Front Locking Devices

#### Front Locking Device      Narrow Front Locking Device      Eco Front Locking Devices

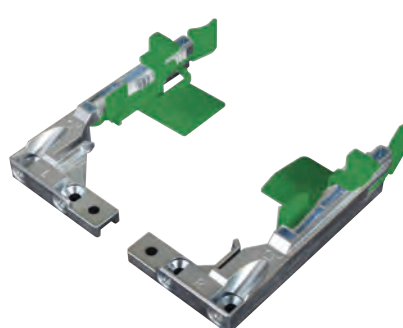

		Drawer Front Thickness				
		12.7	16	19	22	
Subfront Thickness	19	3/4"	18.2	21.5	24.5	27.5
	16	5/8"	15.7	19	22	25
	12.7	1/2"	15.7	19	22	25
Slide Setback						

#### For Subfront 12,13,14,15,16:

Slide Setback = Drawer Front + 3mm

#### For Subfront 17,18,19:

Slide Setback = Drawer Front + Subfront - 13.5mm

		Drawer Front Thickness				
		12.7	16	19	22	
Subfront Thickness	19	3/4"	18.2	21.5	24.5	27.5
	16	5/8"	15.7	19	22	25
	12.7	1/2"	15.7	19	22	25
Slide Setback						

#### For Subfront 12,13,14,15,16:

Slide Setback = Drawer Front + 3mm

#### For Subfront 17,18,19:

Slide Setback = Drawer Front + Subfront - 13.5mm

		Drawer Front Thickness				
		12.7	16	19	22	
Subfront Thickness	19	3/4"	18.2	21.5	24.5	27.5
	16	5/8"	15.7	19	22	25
	12.7	1/2"	15.7	19	22	25
Slide Setback						

#### For Subfront 12,13,14,15,16:

Slide Setback = Drawer Front + 3mm

#### For Subfront 17,18,19:

Slide Setback = Drawer Front + Subfront - 13.5mm



## Slide Setback for 2D and 3D Front Locking Devices

### 3D Flanged Front Locking Device



		Drawer Front Thickness				
		12.7	16	19	22	
Subfront Thickness		1/2"	5/8"	3/4"	7/8"	
	19	3/4"	18.2	21.5	24.5	27.5
	16	5/8"	18.2	21.5	24.5	27.5
	12.7	1/2"	18.2	21.5	24.5	27.5
					Slide Setback	

Slide Setback = Drawer Front + 5.5mm (Based on depth adjuster fully retracted)

Slide setback for inset application based on depth adjuster fully retracted

### 3D Front Locking Device



		Drawer Front Thickness				
		12.7	16	19	22	
Subfront Thickness		1/2"	5/8"	3/4"	7/8"	
	19	3/4"	19.7	22.9	26.1	29.0
	16	5/8"	16.7	19.9	23.1	26.0
	12.7	1/2"	17.2	20.4	23.6	26.5
					Slide Setback	

Slide setback for inset application based on depth adjuster fully retracted

### 2D Flanged Front Locking Device



		Drawer Front Thickness				
		12.7	16	19	22	
Subfront Thickness		1/2"	5/8"	3/4"	7/8"	
	19	3/4"	18.2	21.5	24.5	27.5
	16	5/8"	18.2	21.5	24.5	27.5
	12.7	1/2"	18.2	21.5	24.5	27.5
					Slide Setback	

Slide Setback = Drawer Front + 5.5mm

### 2D Front Locking Device



		Drawer Front Thickness				
		12.7	16	19	22	
Subfront Thickness		1/2"	5/8"	3/4"	7/8"	
	19	3/4"	18.2	21.4	24.6	27.5
	16	5/8"	16.2	19.4	22.6	25.5
	12.7	1/2"	17.2	20.4	23.6	26.5
					Slide Setback	

# Technical Information

## Dynapro

### Dynapro Application

- For drawer material from 12.7mm (1/2") up to 19mm (3/4")
- For frameless or face frame application
- Use rear bracket or blockout for face frame application
- Heavy duty and extended length slides must be blocked out for face frame application

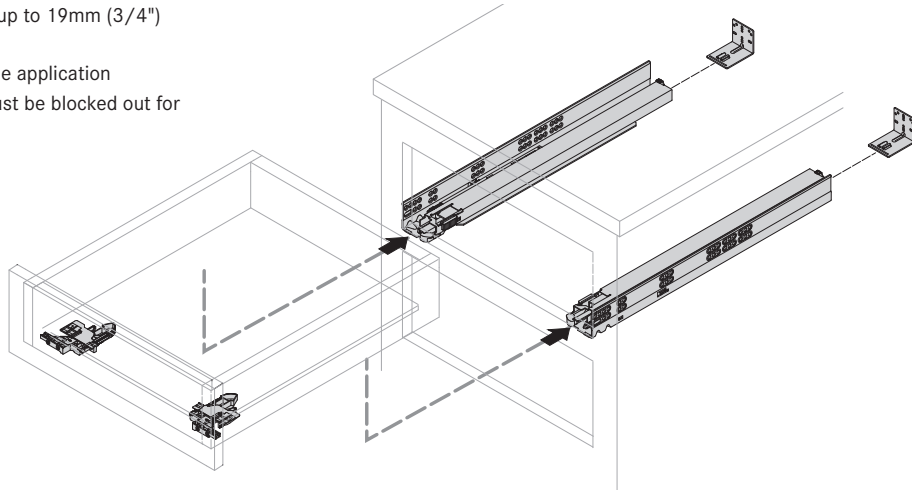

### Inserting the Drawer

Place drawer on extended Dynapro slide and push in until it engages audibly

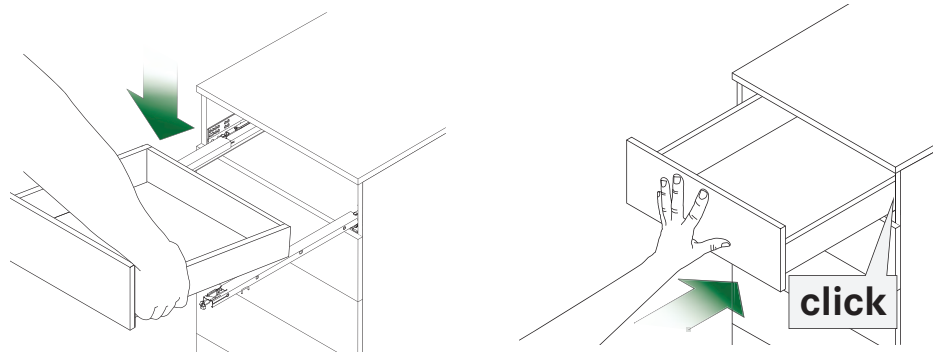

### Disengaging the Drawer

Pull the drawer out, squeeze the locking device levers and lift drawer from the slide.

Front Locking Device

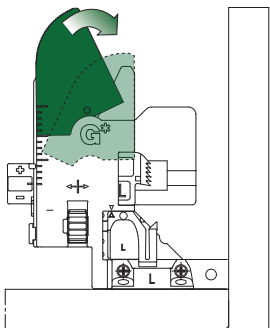

Narrow Front Locking Device

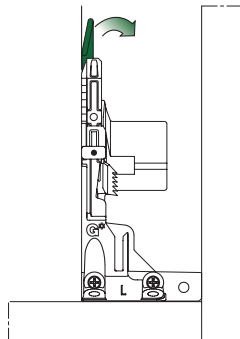

Eco Front Locking Device

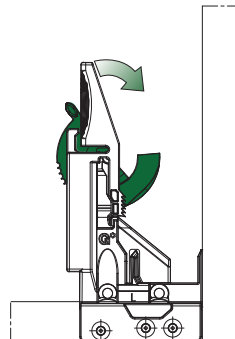

2D/3D Front Locking Devices

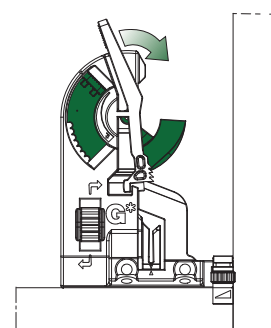

### Weight Capacities per Pair of Slides

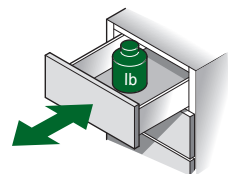

Dynapro and Tipmatic: 100 lb dynamic load rating, 100 lb static load rating

Dynapro Heavy Duty: 132 lb dynamic load rating, 150 lb static load rating

Dynapro Extended Lengths: 110 lb dynamic load rating, 125 lb static load rating

Dynapro meets and exceeds the minimum requirements of ANSI/BHMA A156.9 Standard, Grade 1  
Tested in frameless cabinetry using a minimum of 4 mounting screws

## Height Adjustment (max +3.5mm)

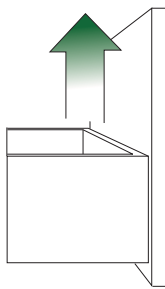

Front Locking Device

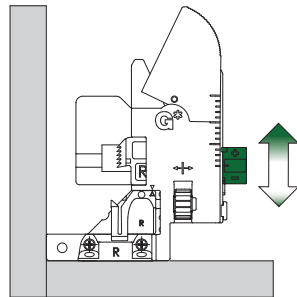

Narrow Front Locking Device

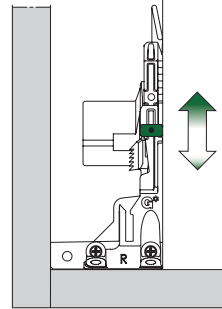

Eco Front Locking Device

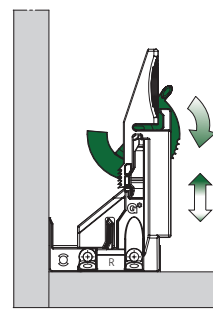

2D/3D Front Locking Devices

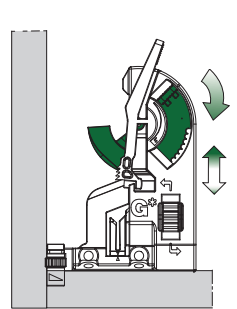

## Side Adjustment (max ±1.5mm)

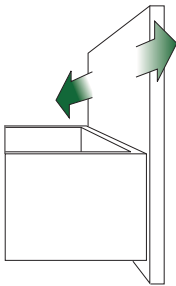

1. Adjust both wheels in the same direction

- For 3D application only:
2. Disengage drawer
  3. Re-attach drawer
  4. Drawer perfectly aligned

Front Locking Device

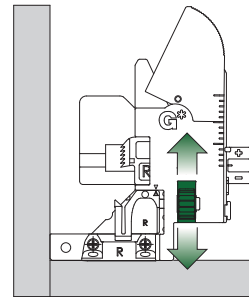

2D/3D Front Locking Devices

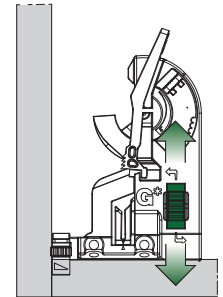

## Tilt Adjustment (max +4.0mm)

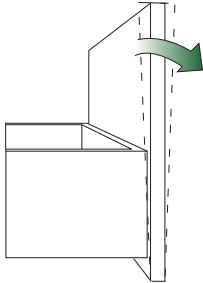

- For 3D application only:
1. Adjust both levers in opposite directions
  2. Disengage drawer
  3. Re-attach drawer

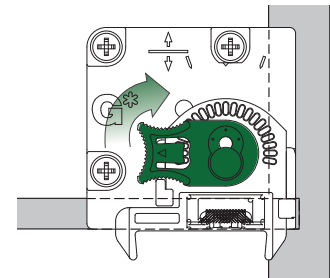

## Depth Adjustment

### With 3D Front Locking Device (3.0mm forward)

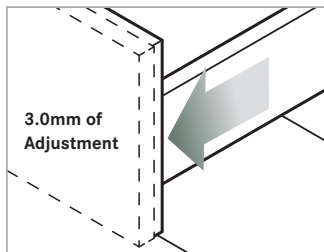

**Adjustment**  
For up to 3.0mm of forward adjustment turn both adjustment wheels toward outside of drawer.

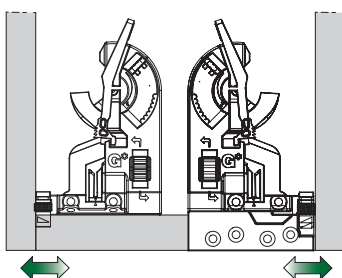

### Additional Option for Dynapro Heavy Duty & Extended Length (+4.5mm forward)

#### Removal & Insertion

For heavy duty & extended length application only:

1. Removal: Press in on tab with screwdriver. Rotate and remove fitting.
2. Insertion: Insert depth fitting and rotate to lock. Fitting tab snaps into place.

#### ① Removal



#### ② Insertion



Screwdriver is required for removal of the standard fitting.

#### Adjustment

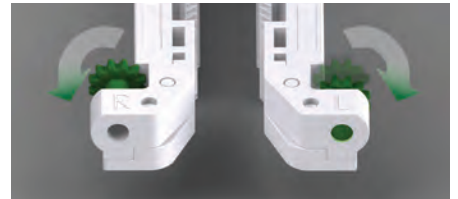

#### Adjustment

Adjust left and right adjustment screws simultaneously in opposite directions



## Dynapro 16, Full Extension Slide, 2D

Integrated Soft-close with optional 3-dimensional adjustment for 16mm (5/8") drawer material



- Face frame or frameless applications from 12.7mm (1/2") up to 16mm (5/8") drawer material
- Full extension with a synchronized mechanism
- Fully enclosed soft-close liquid damping system
- Self-latching front locking devices have easy release levers for drawer removal and installation
- Height adjustment +3.5mm with suitable front locking device
- Side adjustment  $\pm 1.5\text{mm}$  with suitable front locking device
- Depth adjustment +3.0mm forward with suitable front locking device
- 100 lb load rating (45 kg)

### Dynapro 16 Full Extension Slide, 100 lb (45 kg)



Drawer Length	Nominal Length	Min Installation Depth	Max Installation Depth	Item No.	PU
229 (9")	262 (10 5/16")	273 (10 3/4")	352 (13 7/8")	<b>F130135013604</b>	5
305 (12")	323 (12 23/32")	327 (12 7/8")	370 (14 9/16")	<b>F130135014604</b>	5
381 (15")	399 (15 23/32")	403 (15 7/8")	446 (17 9/16")	<b>F130135015604</b>	5
457 (18")	475 (18 11/16")	479 (18 27/32")	522 (20 9/16")	<b>F130135016604</b>	5
533 (21")	551 (21 11/16")	555 (21 27/32")	598 (23 17/32")	<b>F130135019604</b>	5
457 (18")*	475 (18 11/16")	479 (18 27/32")	522 (20 9/16")	<b>F130135016204U</b>	5*
533 (21")*	551 (21 11/16")	555 (21 27/32")	598 (23 17/32")	<b>F130135019204U</b>	5*
PU 5* = bulk					

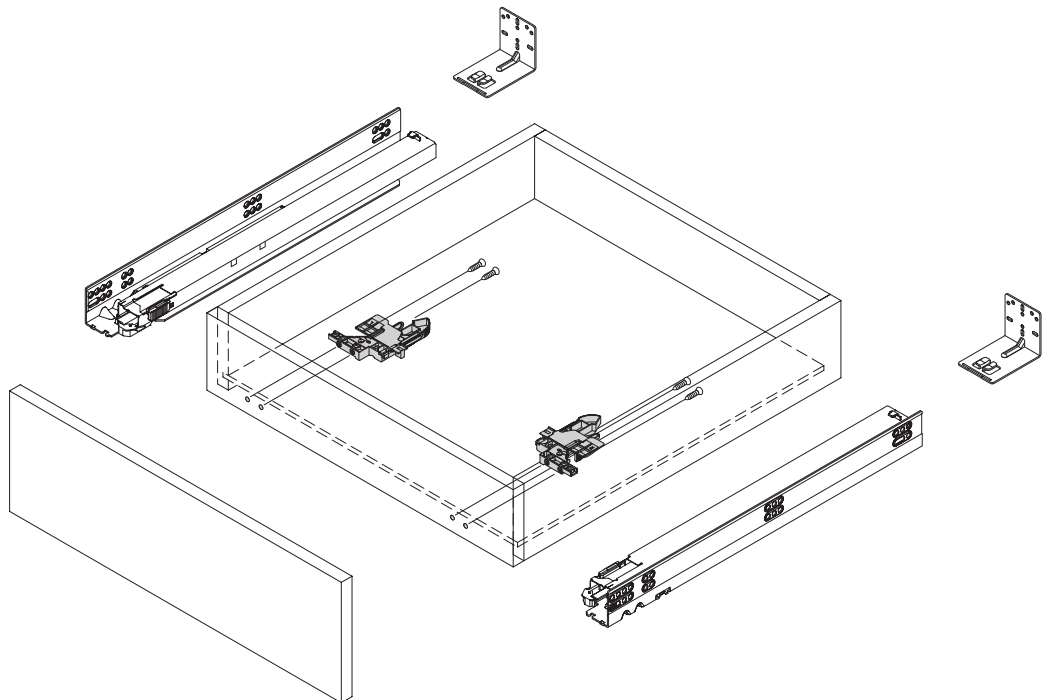

PU - Packaging unit

## Front Locking Devices

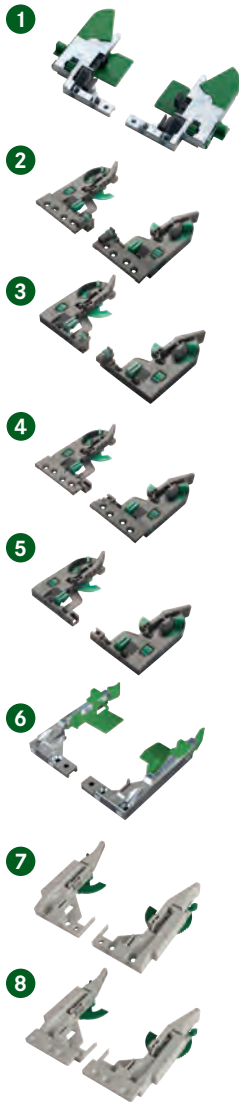

	Description	Adjustments	Item No.	PU
	(Must order separately)			
1	Front locking device, left	height, side	<b>F13412500</b> 633	200
	Front locking device, right	height, side	<b>F13412500</b> 1633	200
	Front locking device, set	height, side	<b>F134101400</b> 104	5
2	3D Flanged front locking device, left	height, side, depth	<b>F13410894</b> 2233	200
	3D Flanged front locking device, right	height, side, depth	<b>F13410894</b> 3233	200
3	3D Front locking device, left	height, side, depth	<b>F13410894</b> 7233	200
	3D Front locking device, right	height, side, depth	<b>F13410894</b> 8233	200
4	2D Flanged front locking device, left	height, side	<b>F13410894</b> 4233	200
	2D Flanged front locking device, right	height, side	<b>F13410894</b> 5233	200
5	2D Front locking device, left	height, side	<b>F13410895</b> 0233	200
	2D Front locking device, right	height, side	<b>F13410895</b> 1233	200
6	Narrow front locking device, left	height	<b>F13410069</b> 9233	200
	Narrow front locking device, right	height	<b>F13410070</b> 0233	200
7	Eco front locking device, left	height	<b>F1341012</b> 21233	200
	Eco front locking device, right	height	<b>F1341012</b> 22233	200
	Eco front locking device, set	height	<b>F1341012</b> 20517	5
8	Eco flanged front locking device, left	height	<b>F1341164</b> 20233	200
	Eco flanged front locking device, right	height	<b>F1341164</b> 21233	200
	Eco flanged front locking device, set	height	<b>F1341164</b> 22204	5

## Rear Mounting Brackets

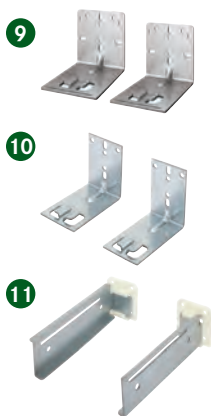

	Description	Item No.	PU
	(Must order separately)		
9	Rear mounting brackets, non-handed for 12"-21" slides, each	7950.VE300	300
10	Narrow rear mounting brackets, non-handed for 12"-21" slides, each	7951.VE300	300
11	Rear mounting sockets for 9" slides, set Set Includes: left and right sockets, (4) #M5 x 8 screw	00433-37	5

# Dynapro 16, Full Extension Slide, 2D

Integrated Soft-close with optional 3-dimensional adjustment for 16mm (5/8") drawer material

## Drawer Measurements

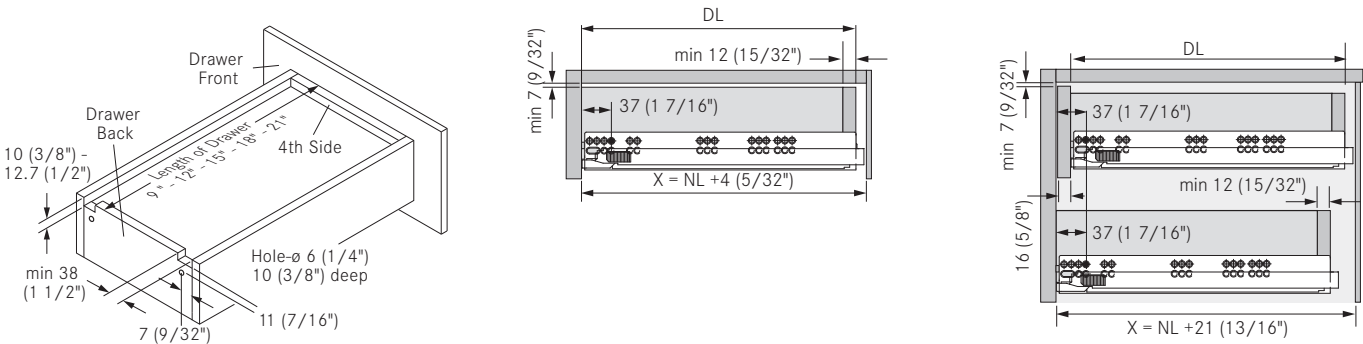

## Front Locking Device Installation

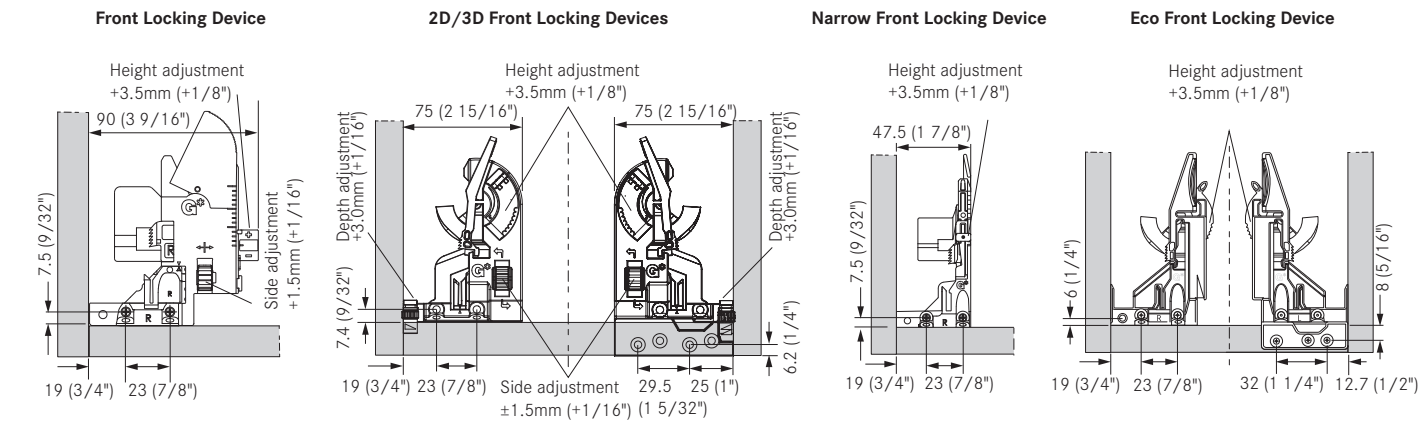

## Drawer Installation Dimensions

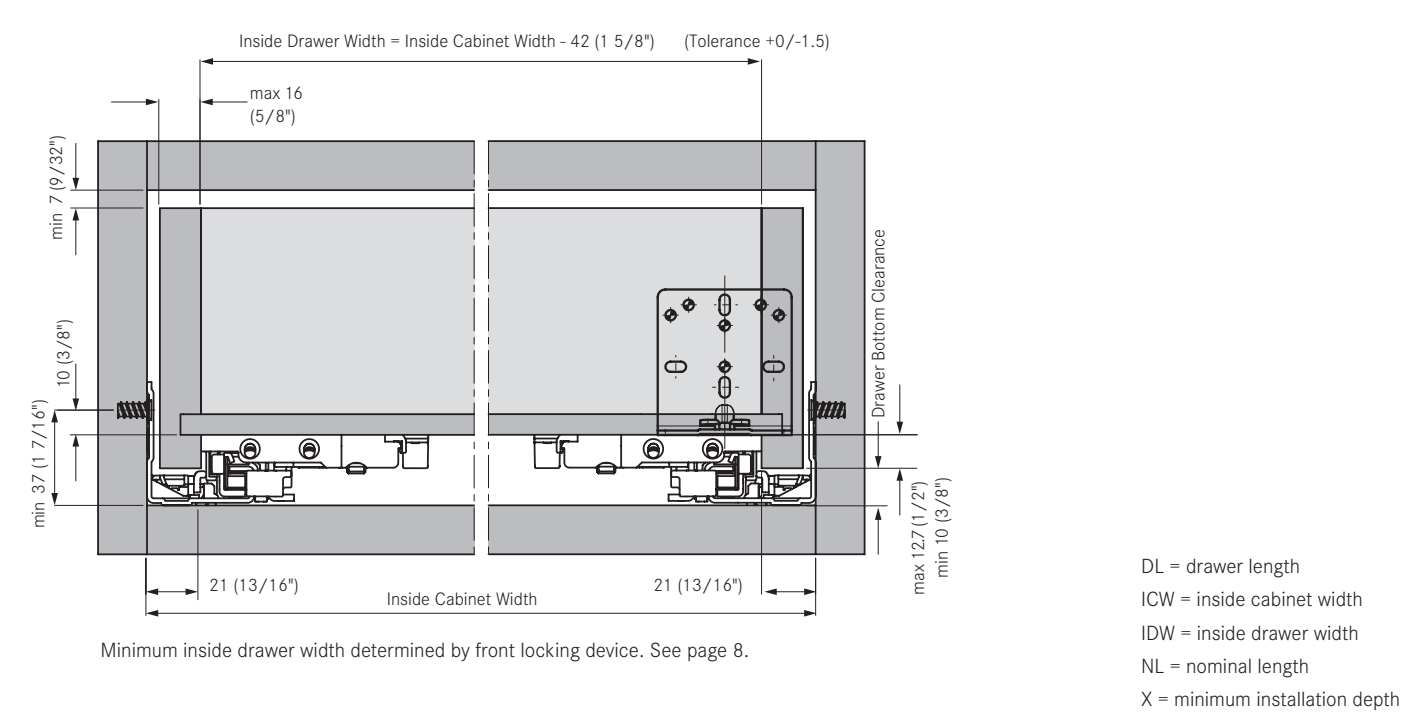



Drawer Material Thickness	16mm (5/8")
Dynamic Load	100 lb (45 kg)
Static Load	100 lb (45 kg)

**Mounting Position for Front Cabinet Profile** **Rear Bracket for Face Frame**

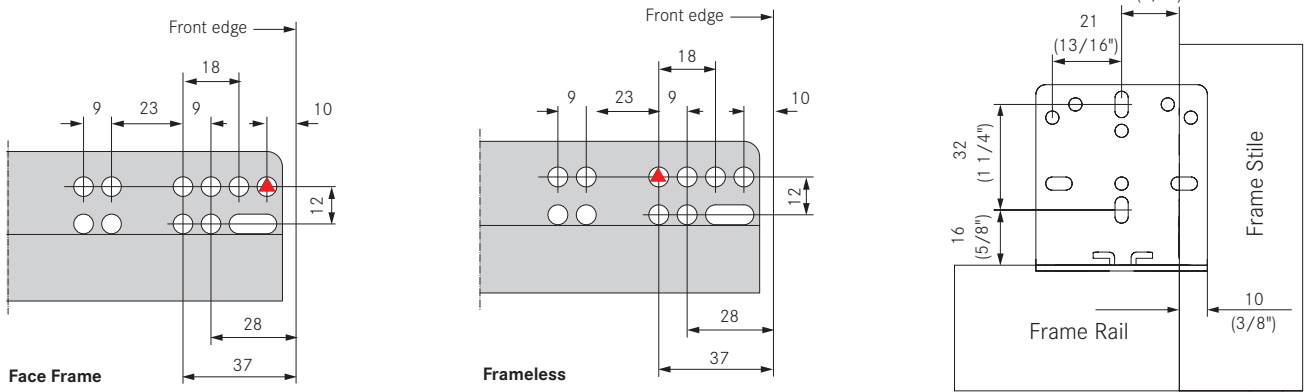

See page 9 for additional rear mounting brackets

**Cabinet Boring Specifications**

**Face Frame**

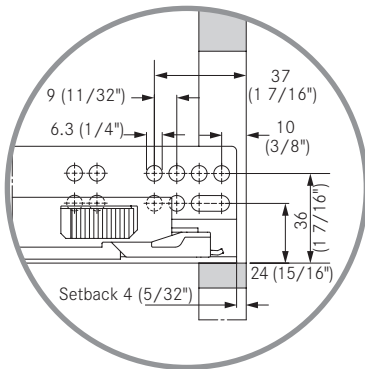
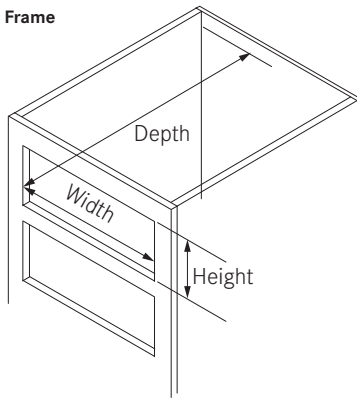

**Frameless**

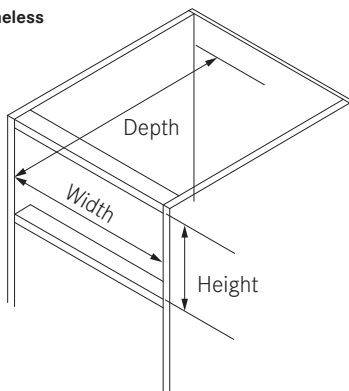

Pre-drilling recommended  $\varnothing 2.5\text{mm}$  (3/32").

Note: The recommendations for screw placement are guidelines only. Installers need to ensure that the cabinet wall is adequate.

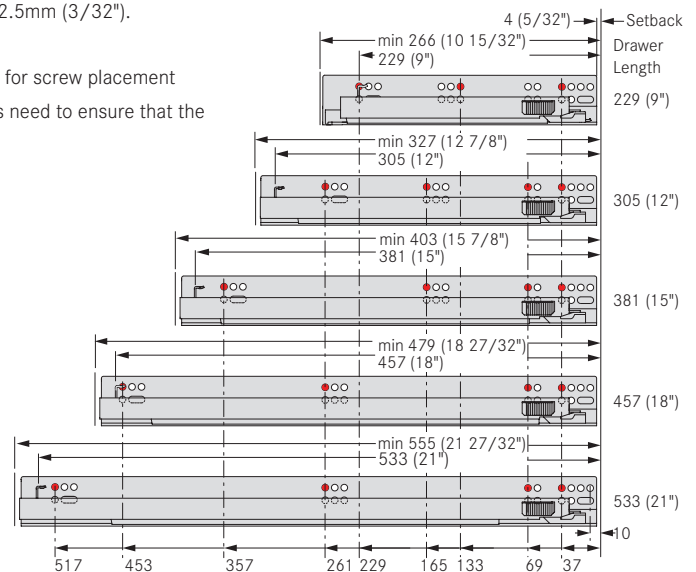

## Dynapro 16, Full Extension Slide, 3D

Integrated Soft-close with optional 4-dimensional adjustment for 16mm (5/8") drawer material



- Face frame or frameless applications from 12.7mm (1/2") up to 16mm (5/8") drawer material
- Full extension with a synchronized mechanism
- Fully enclosed soft-close liquid damping system
- Self-latching front locking devices have comfortable release levers for drawer removal and installation
- Height adjustment +3.5mm with suitable front locking device
- Side adjustment  $\pm 1.5$ mm with suitable front locking device
- Tilt adjustment +4.0mm
- Depth adjustment +3.0mm forward with suitable front locking device
- 100 lb load rating (45 kg)

### Dynapro 16 Full Extension Slide, 100 lb (45 kg)



Drawer Length	Nominal Length	Min Installation Depth	Max Installation Depth	Item No.	PU
229 (9")	262 (10 5/16")	273 (10 3/4")	352 (13 7/8")	<b>F130135003</b> 604	5
305 (12")	323 (12 23/32")	327 (12 7/8")	370 (14 9/16")	<b>F130135004</b> 604	5
381 (15")	399 (15 23/32")	403 (15 7/8")	446 (17 9/16")	<b>F130135005</b> 604	5
457 (18")	475 (18 11/16")	479 (18 27/32")	522 (20 9/16")	<b>F130135006</b> 604	5
533 (21")	551 (21 11/16")	555 (21 27/32")	598 (23 17/32")	<b>F130135007</b> 604	5

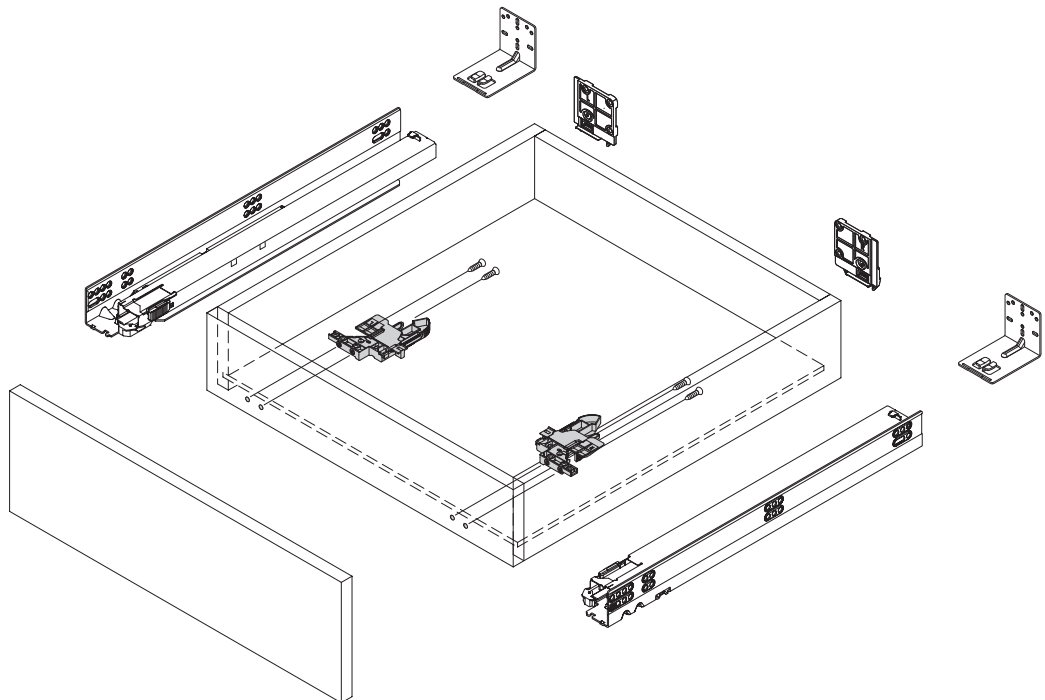

PU - Packaging unit

## Front Locking Devices

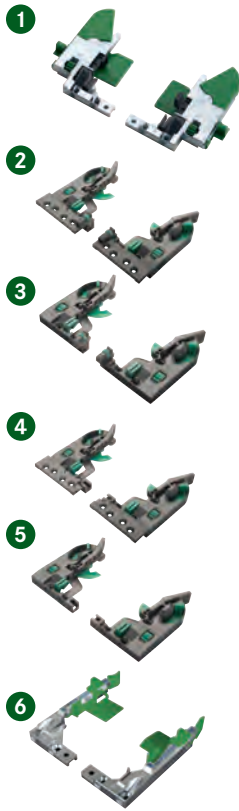

Description	Adjustments	Item No.	PU
(Must order separately)			
<b>1</b> Front locking device, left	height, side	<b>F134125000633</b>	200
Front locking device, right	height, side	<b>F134125001633</b>	200
Front locking device, set	height, side	<b>F134101400104</b>	5
<b>2</b> 3D Flanged front locking device, left	height, side, depth	<b>F134108942233</b>	200
3D Flanged front locking device, right	height, side, depth	<b>F134108943233</b>	200
<b>3</b> 3D Front locking device, left	height, side, depth	<b>F134108947233</b>	200
3D Front locking device, right	height, side, depth	<b>F134108948233</b>	200
<b>4</b> 2D Flanged front locking device, left	height, side	<b>F134108944233</b>	200
2D Flanged front locking device, right	height, side	<b>F134108945233</b>	200
<b>5</b> 2D Front locking device, left	height, side	<b>F134108950233</b>	200
2D Front locking device, right	height, side	<b>F134108951233</b>	200
<b>6</b> Narrow front locking device, left	height	<b>F134100699233</b>	200
Narrow front locking device, right	height	<b>F134100700233</b>	200

## Rear Mounting Brackets and Adjustment Adapters

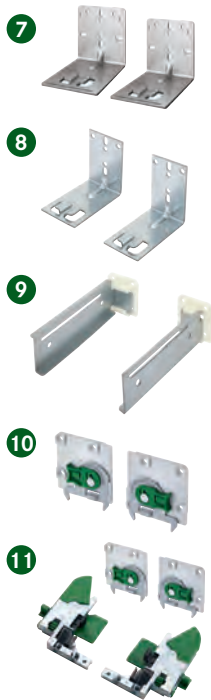

Description	Item No.	PU
(Must order separately)		
<b>7</b> Rear mounting brackets, non-handed for 12"-21" slides, each	7950.VE300	300
<b>8</b> Narrow rear mounting brackets, non-handed for 12"-21" slides, each	7951.VE300	300
<b>9</b> Rear mounting sockets for 9" slides, set Set Includes: left and right sockets, (4) #M5 x 8 screw	00433-37	5
<b>10</b> Tilt adjustment adapter, left	<b>F134125002233</b>	200
Tilt adjustment adapter, right	<b>F134125003233</b>	200
<b>11</b> Front locking device and adjustment adapter set Set Includes: Front locking device set and tilt adjustment adapter set	<b>F134125074517</b>	1

# Dynapro 16, Full Extension Slide, 3D

Integrated Soft-close with optional 4-dimensional adjustment for 16mm (5/8") drawer material

## Drawer Measurements

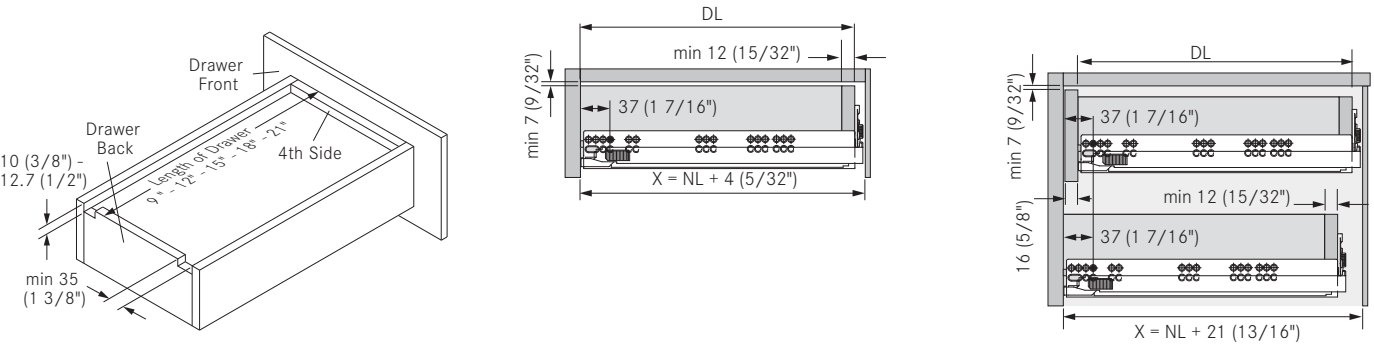

## Front Locking Device Installation

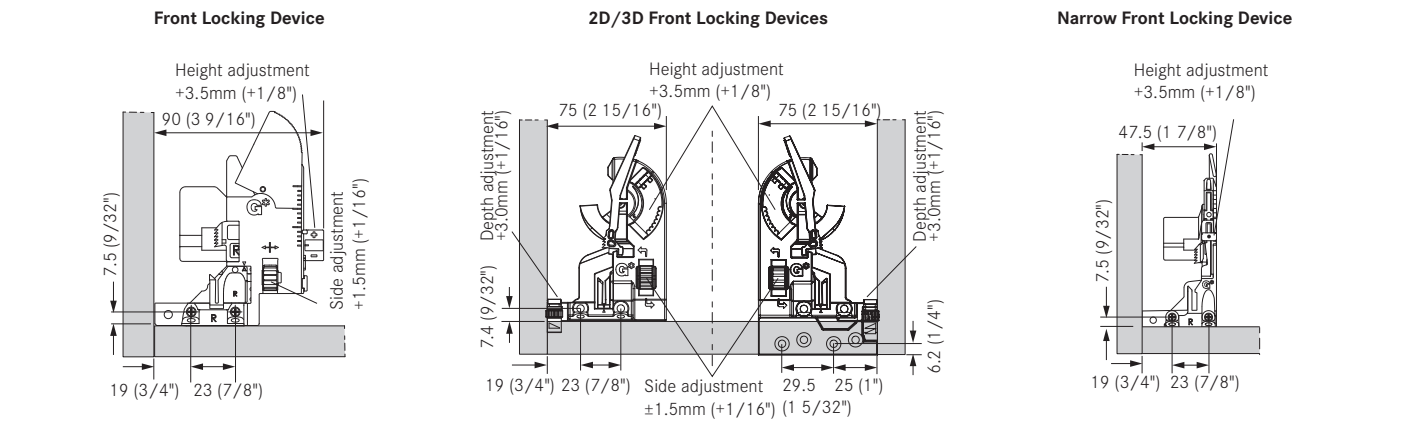

## Drawer Installation Dimensions

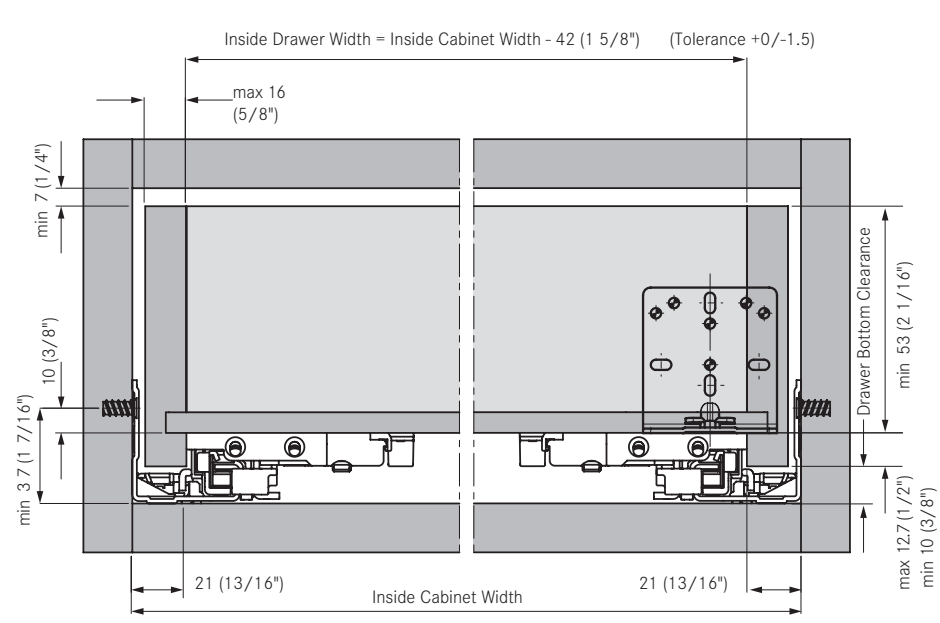

## Tilt Adjustment Adapter Installation

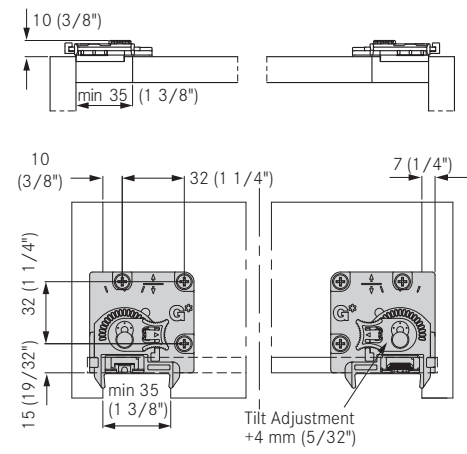

DL = drawer length  
 ICW = inside cabinet width  
 IDW = inside drawer width  
 NL = nominal length  
 X = minimum installation depth

Minimum inside drawer width determined by front locking device. See page 8.



Drawer Material Thickness	16mm (5/8")
Dynamic Load	100 lb (45 kg)
Static Load	100 lb (45 kg)

**Mounting Position for Front Cabinet Profile** **Rear Bracket for Face Frame**

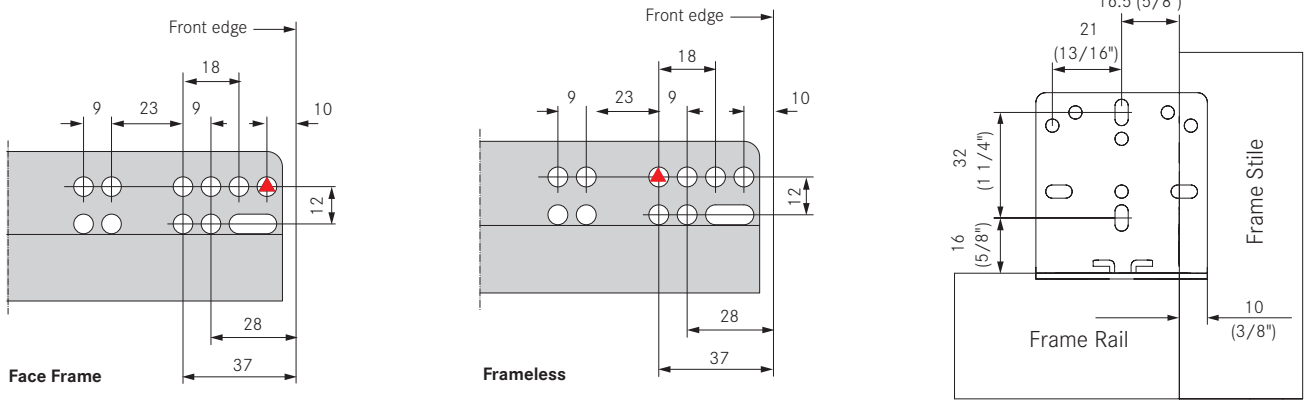

See page 9 for additional rear mounting brackets

**Cabinet Boring Specifications**

**Face Frame**

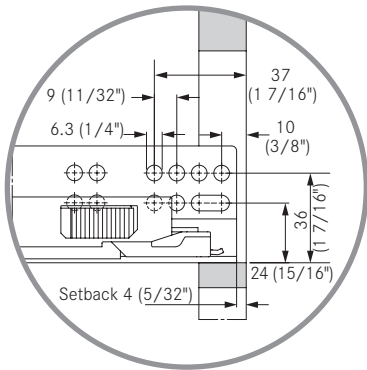
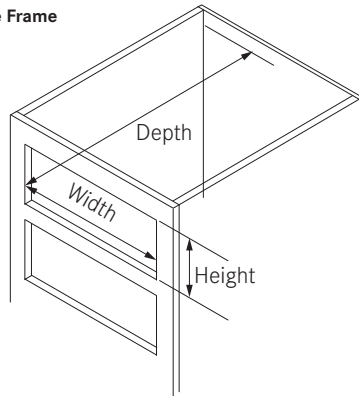

**Frameless**

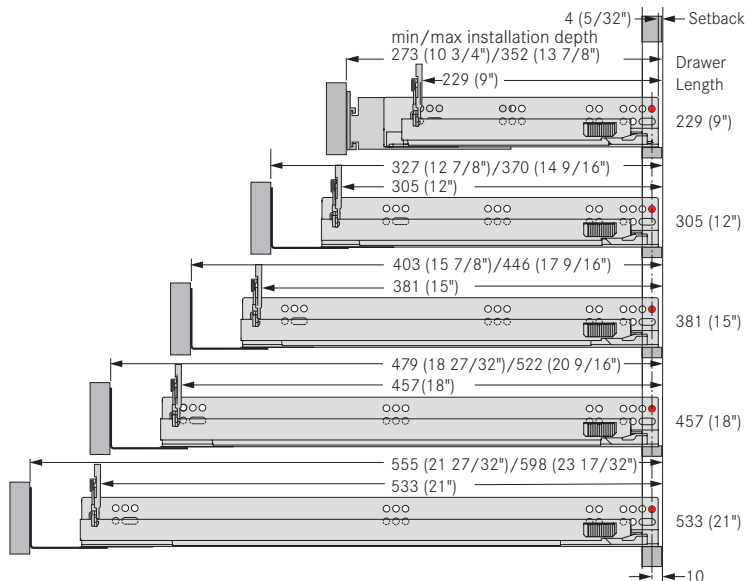
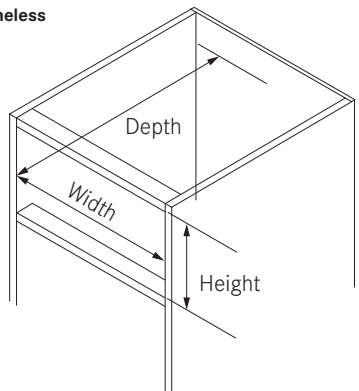

Pre-drilling recommended Ø2.5mm (3/32").

Note: The recommendations for screw placement are guidelines only. Installers need to ensure that the cabinet wall is adequate.

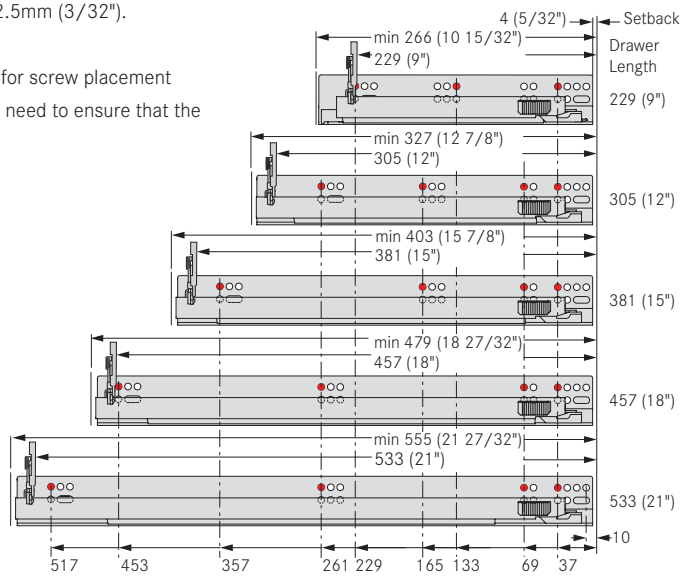

# Dynapro 16, Heavy Duty and Extended Length Slide, 3D

Integrated Soft-close with optional 4-dimensional adjustment for 16mm (5/8") drawer material



- Face frame or frameless applications from 12.7mm (1/2") up to 16mm (5/8") drawer material
- Face frame application must be blocked out
- Full extension with a synchronized mechanism
- Fully enclosed soft-close liquid damping system
- Self-latching front locking devices have comfortable release levers for drawer removal and installation
- Height adjustment +3.5mm
- Side adjustment ±1.5mm
- Tilt adjustment +4.0mm
- Depth adjustment +4.5mm (optional)
- 132 lb load rating (60 kg) heavy duty
- 110 lb load rating (50 kg) extended length

## Dynapro 16 Full Extension Slide, 132 lb (60 kg) and 110 lb (50 kg)



Drawer Length	Nominal Length	Min Installation Depth	Item No.	PU
457 (18")	475 (18 11/16")	479 (18 27/32")	<b>F130135008</b> 604	5
533 (21")	551 (21 11/16")	555 (21 27/32")	<b>F130135009</b> 604	5
610 (24")	628 (24 23/32")	632 (24 7/8")	<b>F130135010</b> 604	5
686 (27")*	704 (27 23/32")	708 (27 7/8")	<b>F130135011</b> 604	5
762 (30")*	780 (30 23/32")	784 (30 7/8")	<b>F130135012</b> 604	5

\*Extended lengths, 110 lb (50 kg)

Note: Heavy duty and extended length slides must be blocked out for face frame application.

## Front Locking Devices and Adjustment Adapters

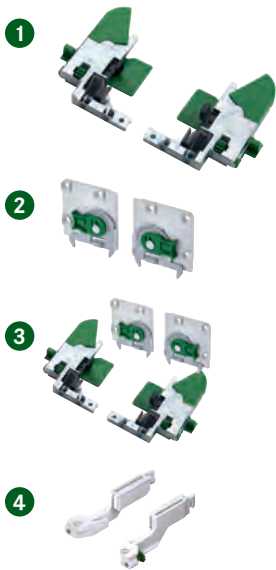

Description	Adjustments	Item No.	PU
(Must order separately)			
1 Front locking device, left	height, side	<b>F134125000</b> 633	200
Front locking device, right	height, side	<b>F134125001</b> 633	200
Front locking device, set	height, side	<b>F134101400</b> 104	5
2 Tilt adjustment adapter, left		<b>F134125002</b> 233	200
Tilt adjustment adapter, right		<b>F134125003</b> 233	200
3 Front locking device and adjustment adapter set		<b>F134125074</b> 517	1
Set Includes: Front locking device set and tilt adjustment adapter set			
4 Depth adjustment for drawer front, left and right, set, optional		<b>F134101002</b> 104	5

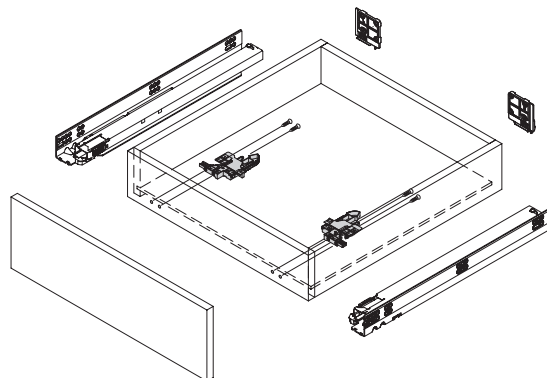

PU - Packaging unit

Drawer Material Thickness	16mm (5/8")
Dynamic Load	* 132 lb (60 kg)
Static Load	* 150 lb (70 kg)
Adjustment (depth optional)	Tilt & Depth

**Drawer Measurements      Drawer      Inset Roll-out Drawer**

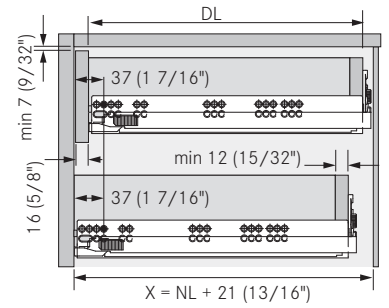
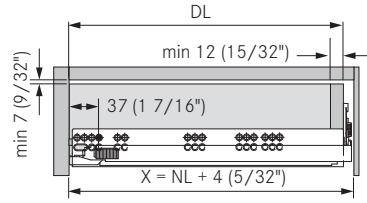
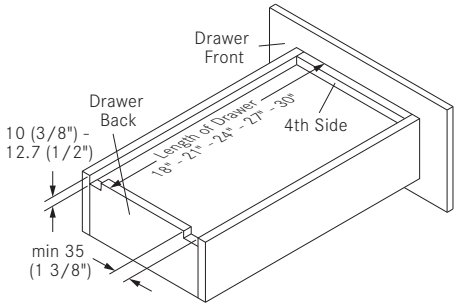

**Front Locking Device Installation      Drawer Installation Dimensions      Mounting Position for Front Cabinet Profile**

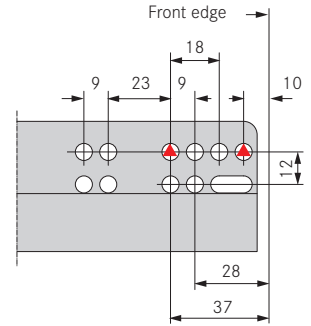
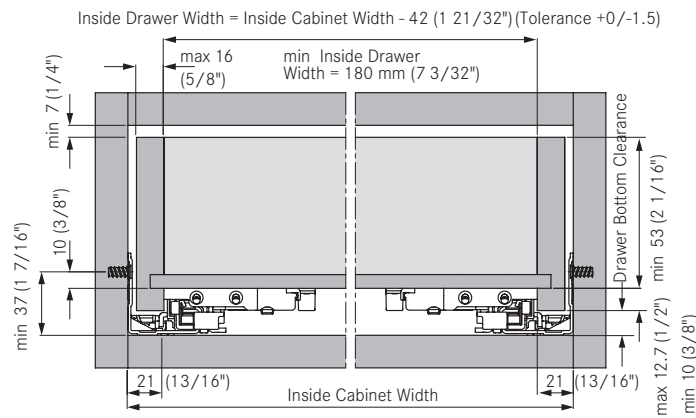
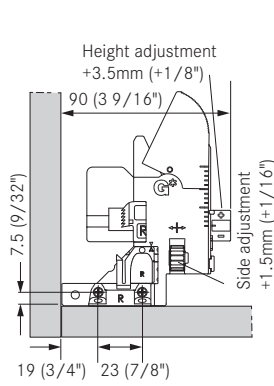

**Tilt Adjustment Adapter Installation      Cabinet Boring Specifications**

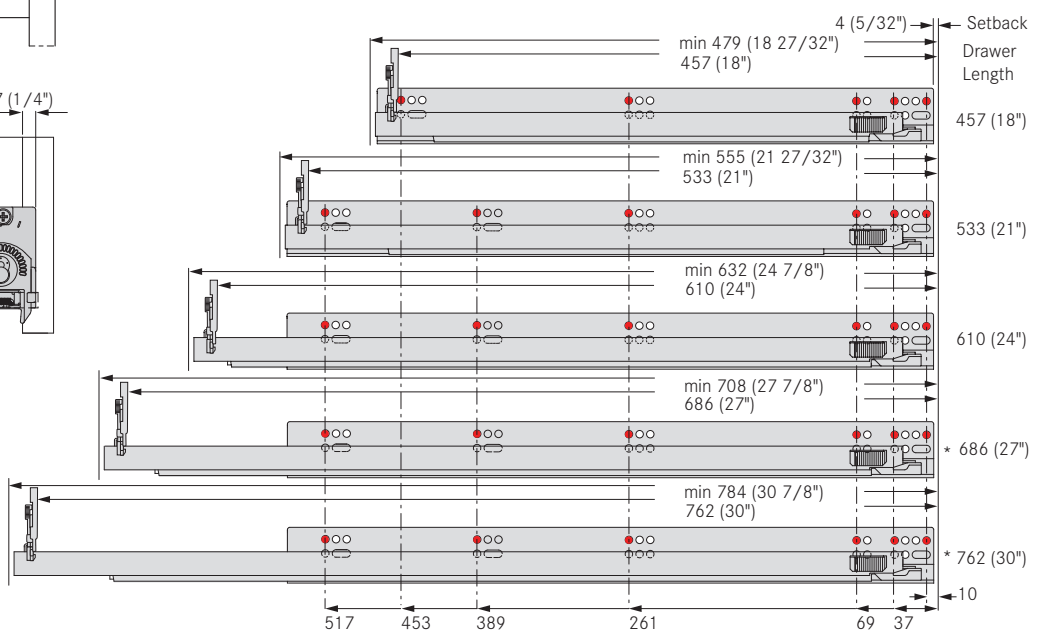
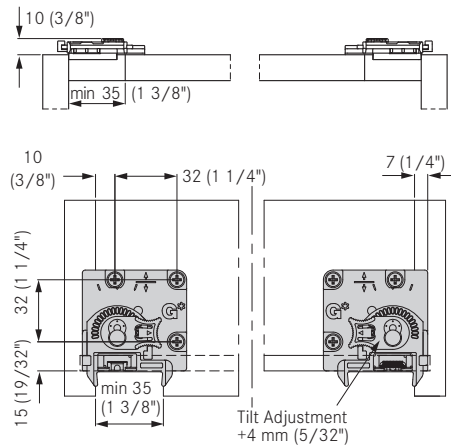

Pre-drilling recommended  $\varnothing 2.5\text{mm}$  (3/32").  
 Note: The recommendations for screw placement are guidelines only. Installers need to ensure that the cabinet wall is adequate.

DL = drawer length  
 ICW = inside cabinet width  
 IDW = inside drawer width  
 NL = nominal length  
 X = minimum installation depth

\* 110 lb dynamic load and 125 lb static load for extended lengths.

All dimensions in millimeters.

# Dynapro 16, Tipmatic

Tipmatic full extension for 16mm (5/8") drawer material



- Integrated Tipmatic
- Full extension with a synchronized mechanism
- Designed for drawers without pulls
- Face frame or frameless applications from 12.7mm (1/2") up to 16mm (5/8") drawer material
- Secure and smooth operation even if drawer is pulled open
- Self-latching front locking devices have comfortable release levers for drawer removal and installation
- Height adjustment +3.5mm with front locking device
- Drawer widths should not exceed 26" wide

## Dynapro 16 Tipmatic Full Extension Slide, 88 lb (40 kg)



Drawer Length	Nominal Length	Min Installation Depth	Item No.	PU
381 (15")	399 (15 23/32")	403 (15 7/8")	<b>F130116432</b> 204	5
457 (18")	475 (18 11/16")	479 (18 27/32")	<b>F130116433</b> 204	5
533 (21")	551 (21 11/16")	555 (21 27/32")	<b>F130116434</b> 204	5

## Front Locking Devices and Rear Mounting Brackets

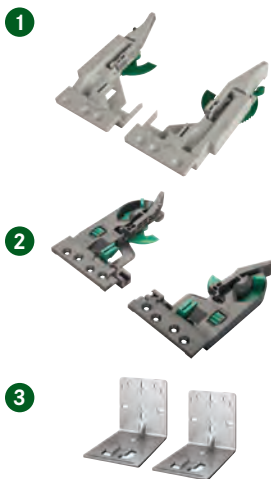

Description	Adjustments	Item No.	PU
(Must order separately)			
1 Eco flanged front locking device, left	height	<b>F134116420</b> 233	200
Eco flanged front locking device, right	height	<b>F134116421</b> 233	200
Eco flanged front locking device, set	height	<b>F134116422</b> 204	5
2 2D Flanged front locking device, left	height, side	<b>F134108944</b> 233	200
2D Flanged front locking device, right	height, side	<b>F134108945</b> 233	200
3 Rear mounting brackets, non-handed for 12"-21" slides, each		7950.VE300	300

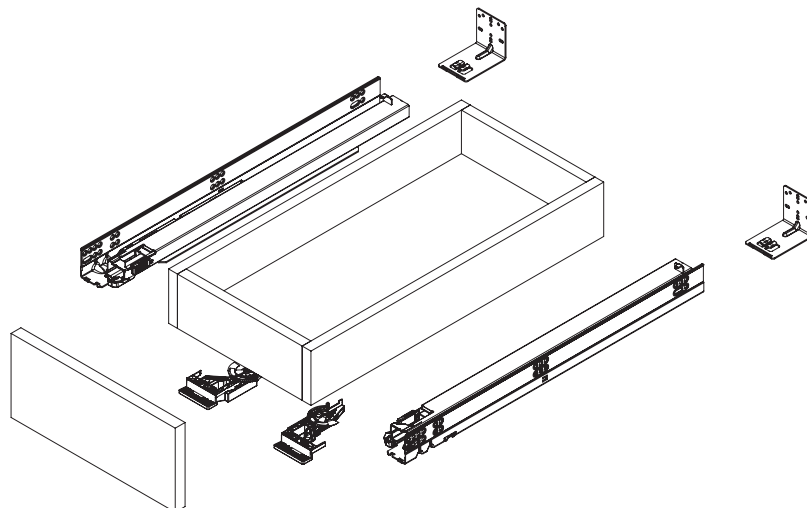

PU - Packaging unit



**Drawer Measurements      Drawer      Front Locking Device Position**

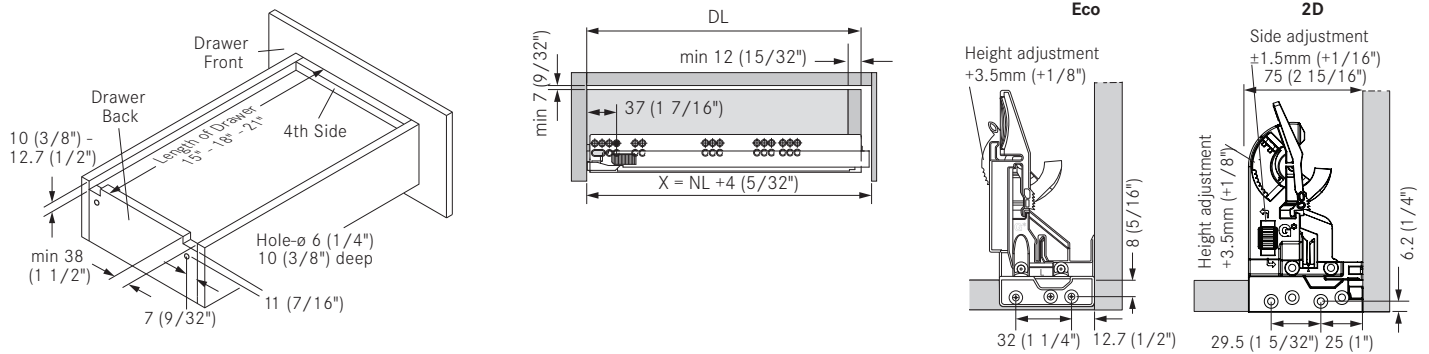

**Drawer Installation Dimensions      Mounting Position for Front Cabinet Profile**

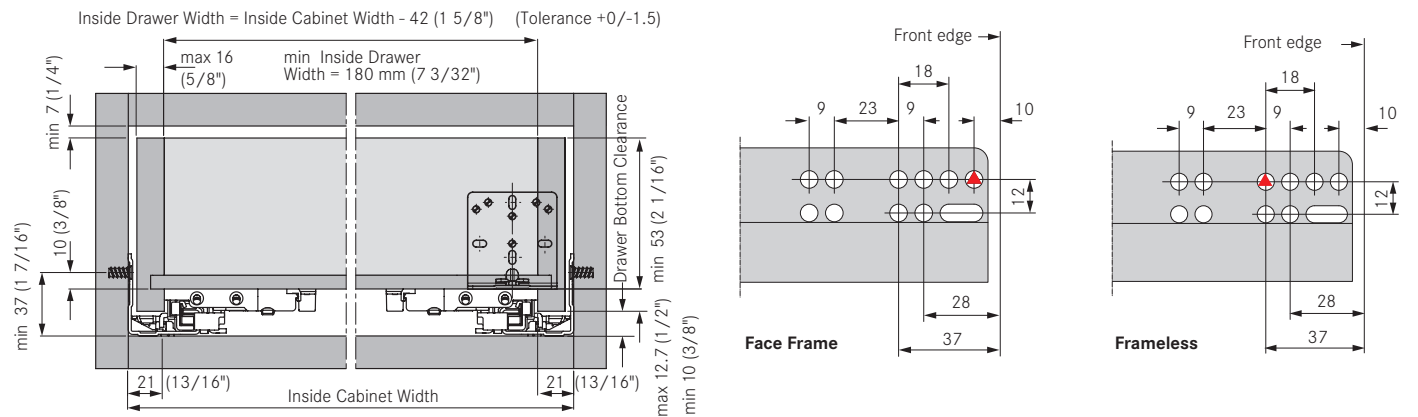

**Rear Bracket for Face Frame      Cabinet Boring Specifications**

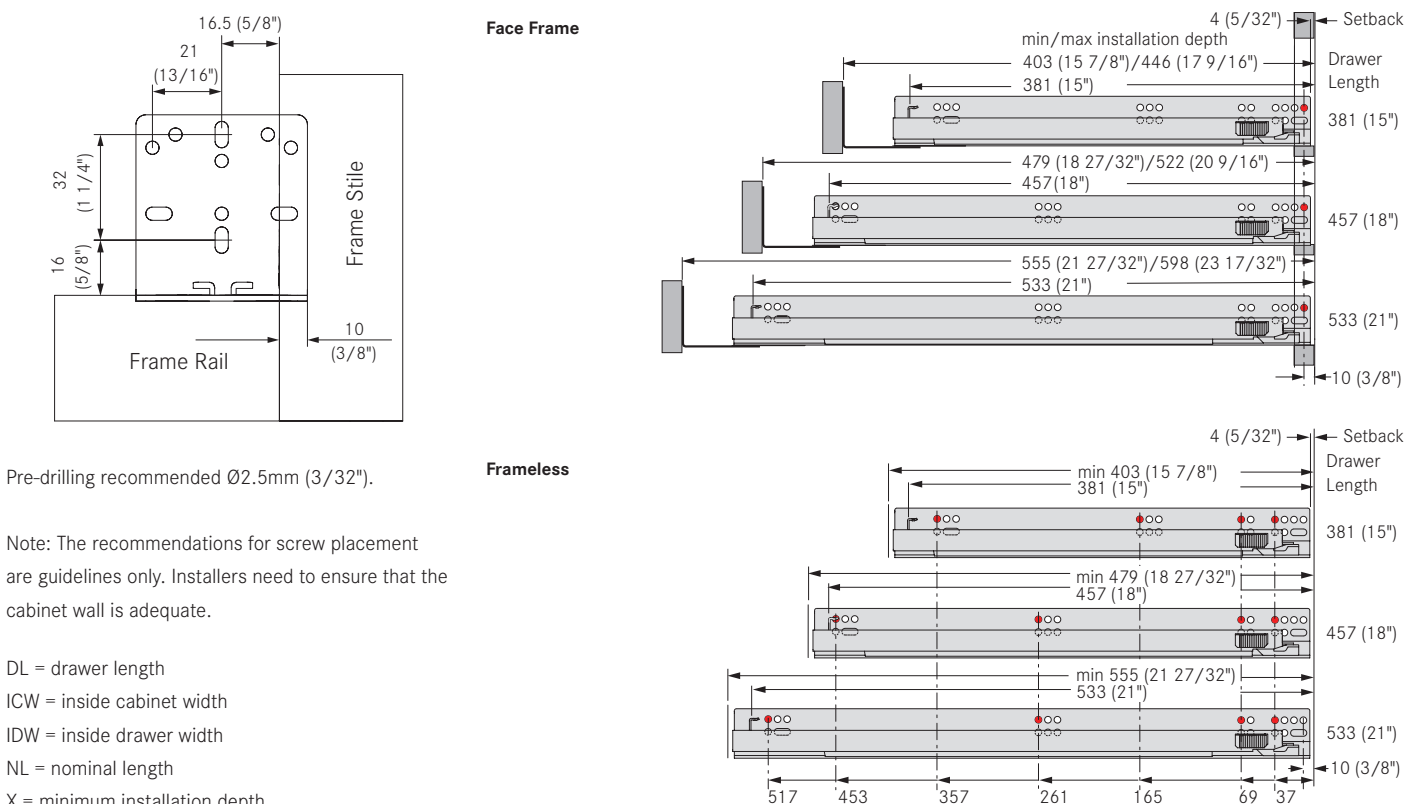

Pre-drilling recommended Ø2.5mm (3/32").

Note: The recommendations for screw placement are guidelines only. Installers need to ensure that the cabinet wall is adequate.

- DL = drawer length
- ICW = inside cabinet width
- IDW = inside drawer width
- NL = nominal length
- X = minimum installation depth

All dimensions in millimeters.

# Dynapro Tipmatic Soft-close

For 16mm (5/8") drawer material

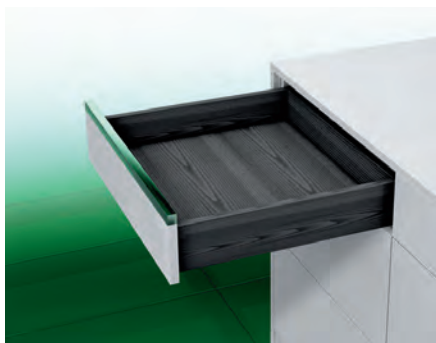

- Face frame or frameless applications from 12.7mm (1/2") up to 16mm (5/8") drawer material
- Mechanical opening system for handle-free fronts
- Combines Tipmatic function with Soft-close damping
- Tool-free assembly of the Tipmatic Soft-close unit
- One unit for nominal lengths 305mm (12") up to 762mm (30")
- 3-tier adjustment for the opening force
- Wide activation zone due to synchronization bar
- Works with all Dynapro types including heavy duty
- Works with Vionaro drawers
- Dynapro Tipmatic Soft-close works with all Dynapro front locking devices
- For drawer widths up to 1168mm (46")

## Tipmatic Soft-close

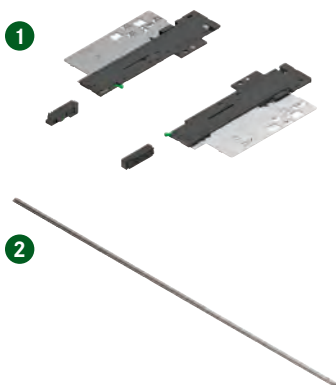

Description	Item No.	PU
(Must order separately)		
1 Tipmatic Soft-close set, unit and activator	<b>F134109323607</b>	10
2 Tipmatic synchronization bar - cut to length, 952mm (37 1/2")	<b>F134109410207</b>	10

Note: Tipmatic Soft-close does not work with 9" slides.

Drawer Length	Nominal Length	Min Inst. Depth	Max Inst. Depth
305 (12")	323 (12 23/32")	327 (12 7/8")	370 (14 9/16")
381 (15")	399 (15 23/32")	403 (15 7/8")	446 (17 9/16")
457 (18")	475 (18 11/16")	479 (18 27/32")	522 (20 9/16")
533 (21")	551 (21 11/16")	555 (21 27/32")	598 (23 17/32")
610 (24")	628 (24 23/32")	632 (24 7/8")	-
686 (27")	704 (27 23/32")	708 (27 7/8")	-
762 (30")	780 (24 23/32")	784 (30 7/8")	-

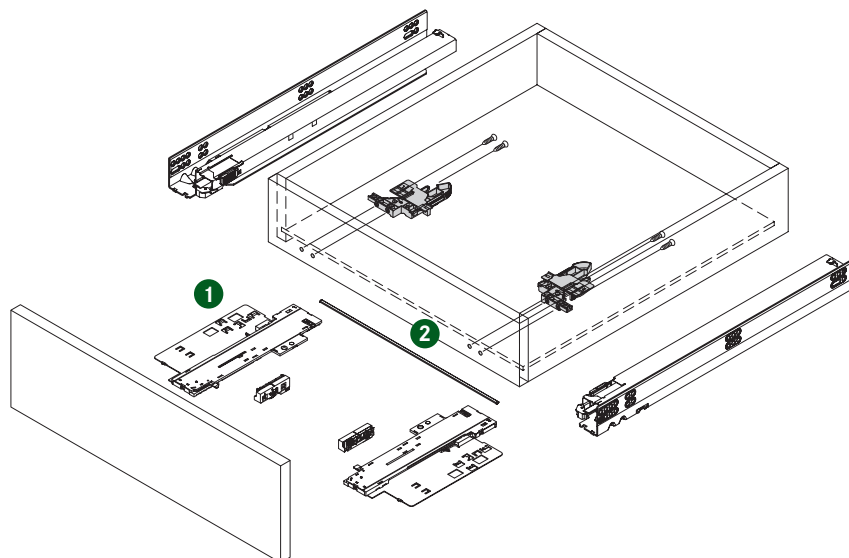

PU - Packaging unit

**Drawer Measurements** **Drawer Installation Dimensions**

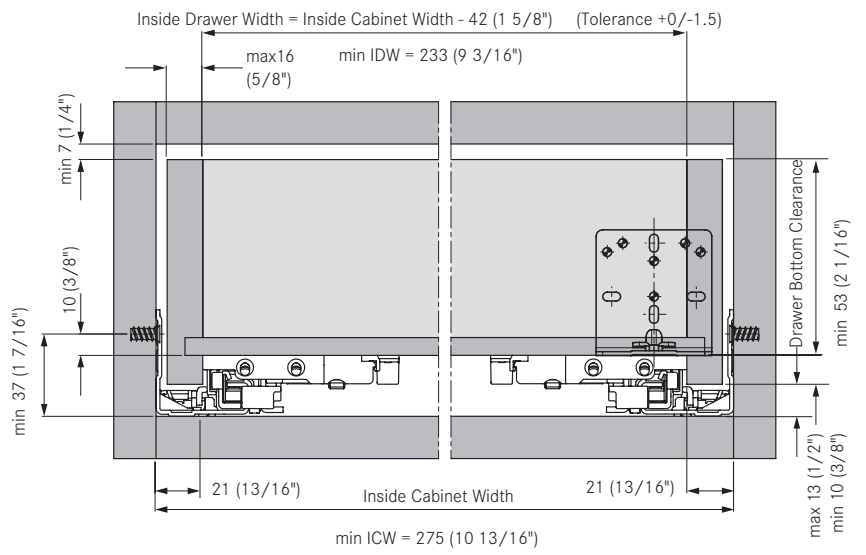
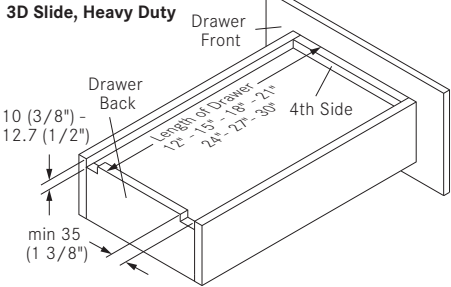
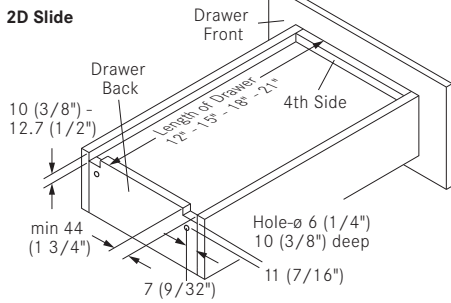

**Synchronization Bar** **Drawer** **Inset Roll-out Drawer**

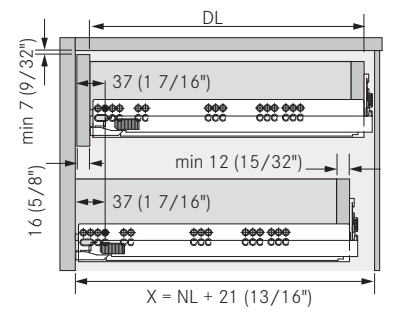
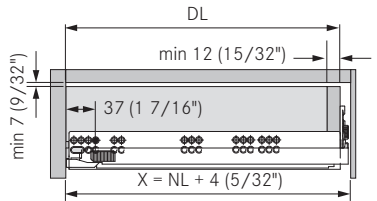
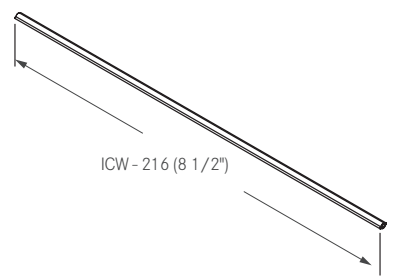

**Position of the Synchronization Bar** **Tilt Adjustment Adapter Installation**

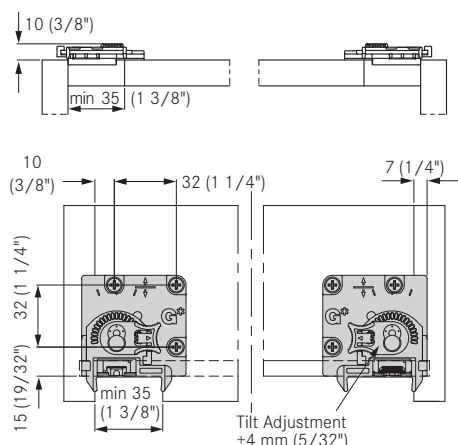
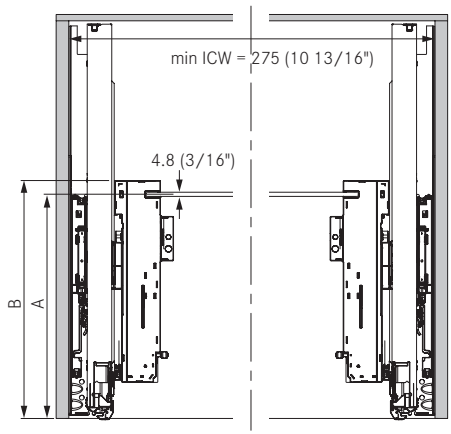

Drawer Length	A	B
305 (12")	261 (10 9/32")	278 (10 15/16")
381 - 762 (15 - 30")	296 (11 21/32")	313 (12 5/16")

DL = drawer length  
 ICW = inside cabinet width  
 IDW = inside drawer width  
 NL = nominal length  
 X = minimum installation depth

All dimensions in millimeters.

# Dynapro Pull Out Shelf

## Base Panel Mount Drawer Slides and 1D Front Locking Device Set

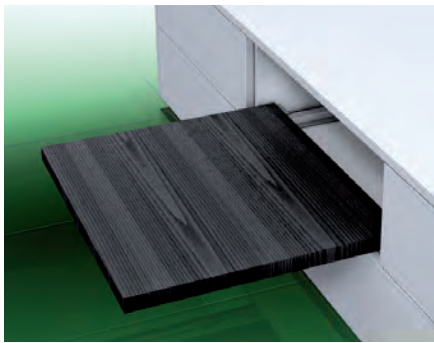

- Full extension with a synchronized mechanism
- Soft-close damping system
- Lower cabinet members allow for pull-out shelf
- Suitable for inset shelves
- Height adjustment +3.5mm with front locking device
- 88 lb load rating (40 kg)
- For frameless cabinetry

### Dynapro Base Panel Mount Drawer Slides, 88 lb (40 kg)



Nominal length	Min Installation Depth	Item No.	PU
450 (18")	403 (15 7/8")	<b>F130107884</b> 604	5
500 (20")	479 (18 27/32")	<b>F130107890</b> 604	5
550 (22")	555 (21 27/32")	<b>F130107893</b> 604	5

### Front Locking Device



Description	Item No.	PU
(Must order separately)		
1D Front locking device & shelf holder, set	<b>F134107411</b> 517	50

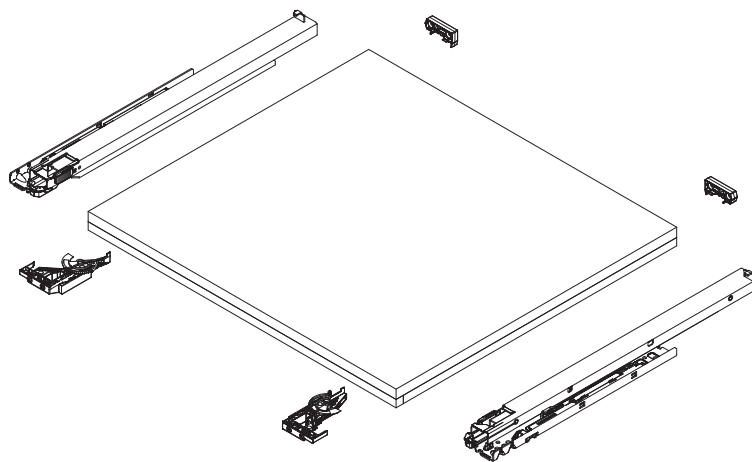

PU - Packaging unit

Dynamic Load	88 lb (40 kg)
Static Load	100 lb (45 kg)

### Drawer Measurements

### Pull Out Shelf

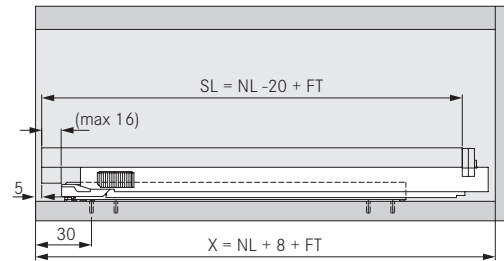
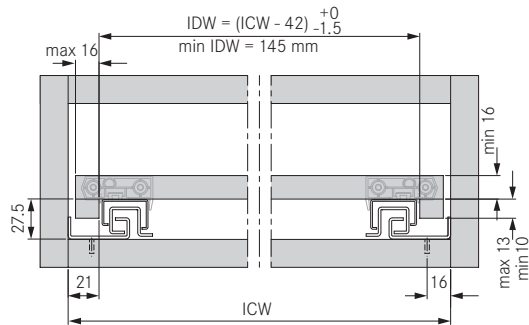

### Front Locking Device Installation

### Shelf Holder Installation

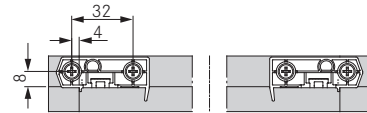
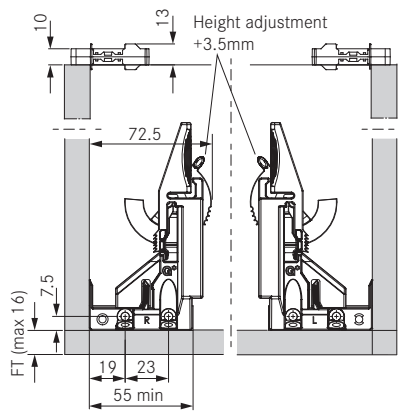

### Cabinet Boring Specifications - Top View

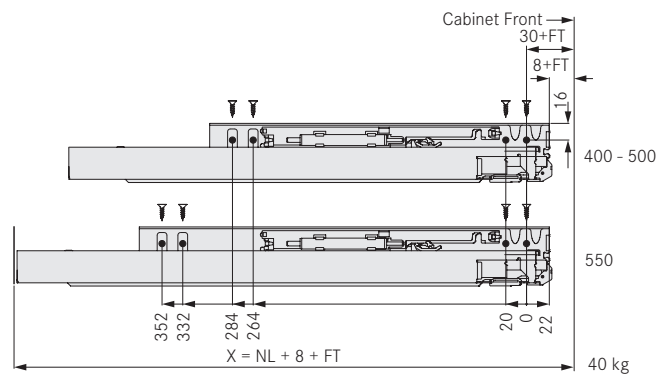

- FT = front thickness
- ICW = inside cabinet width
- IDW = inside drawer width
- NL = nominal length
- SL = shelf length
- X = minimum installation depth



## Dynapro 19, Full Extension Slide, 2D

Integrated Soft-close with optional 3-dimensional adjustment for 19mm (3/4") drawer material



- Face frame or frameless applications from 16mm (5/8") up to 19mm (3/4") drawer material
- Full extension with a synchronized mechanism
- Fully enclosed soft-close liquid damping system
- Self-latching front locking devices have easy release levers for drawer removal and installation
- Integrated 2-dimensional adjustment for alignment
- Height adjustment +3.5mm with suitable front locking device
- Side adjustment  $\pm 1.5\text{mm}$  with suitable front locking device
- Depth adjustment +3.0mm forward with suitable front locking device
- 100 lb load rating (45 kg)

### Dynapro 19 Full Extension Slide, 100 lb (45 kg)



Drawer Length	Nominal Length	Min Installation Depth	Max Installation Depth	Item No.	PU
229 (9")	262 (10 5/16")	273 (10 3/4")	352 (13 7/8")	<b>F130135030</b> 604	5
305 (12")	323 (12 23/32")	327 (12 7/8")	370 (14 9/16")	<b>F130135031</b> 604	5
381 (15")	399 (15 23/32")	403 (15 7/8")	446 (17 9/16")	<b>F130135032</b> 604	5
457 (18")	475 (18 11/16")	479 (18 27/32")	522 (20 9/16")	<b>F130135033</b> 604	5
533 (21")	551 (21 11/16")	555 (21 27/32")	598 (23 17/32")	<b>F130135034</b> 604	5

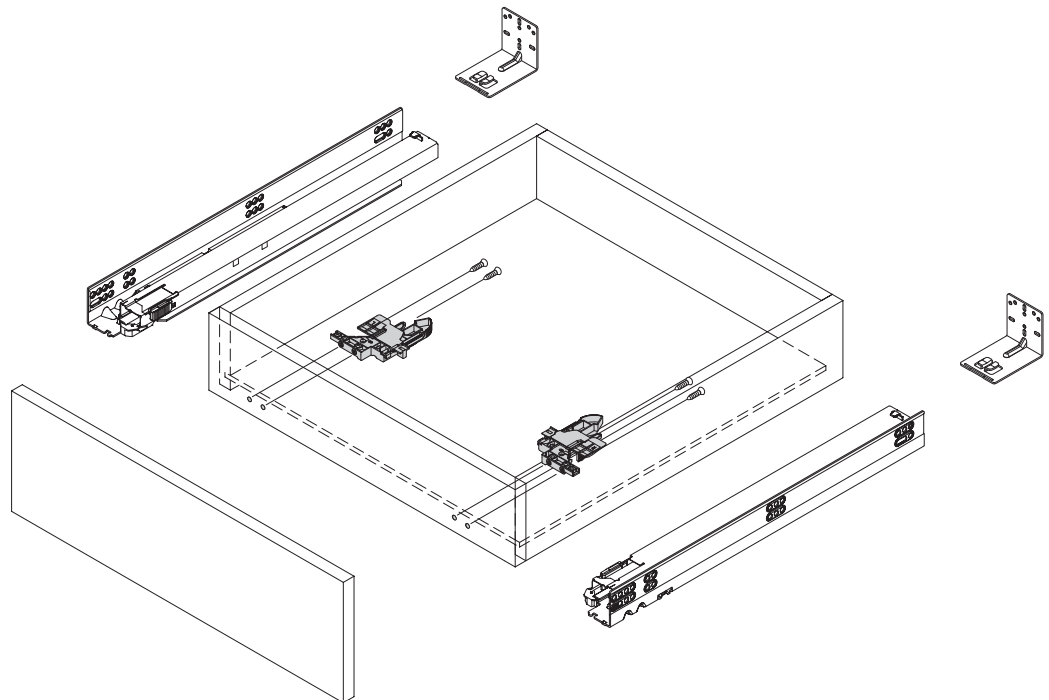

PU - Packaging unit

### Front Locking Devices

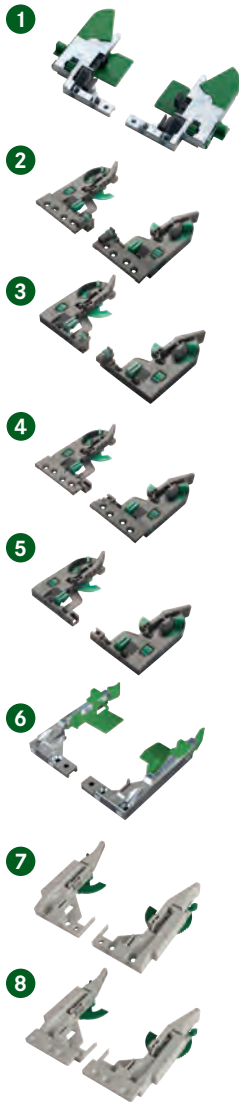

	Description	Adjustments	Item No.	PU
	(Must order separately)			
1	Front locking device, left	height, side	F13412500633	200
	Front locking device, right	height, side	F134125001633	200
	Front locking device, set	height, side	F134101400104	5
2	3D Flanged front locking device, left	height, side, depth	F134108942233	200
	3D Flanged front locking device, right	height, side, depth	F134108943233	200
3	3D Front locking device, left	height, side, depth	F134108947233	200
	3D Front locking device, right	height, side, depth	F134108948233	200
4	2D Flanged front locking device, left	height, side	F134108944233	200
	2D Flanged front locking device, right	height, side	F134108945233	200
5	2D Front locking device, left	height, side	F134108950233	200
	2D Front locking device, right	height, side	F134108951233	200
6	Narrow front locking device, left	height	F134100699233	200
	Narrow front locking device, right	height	F134100700233	200
7	Eco front locking device, left	height	F134101221233	200
	Eco front locking device, right	height	F134101222233	200
	Eco front locking device, set	height	F134101220517	5
8	Eco flanged front locking device, left	height	F134116420233	200
	Eco flanged front locking device, right	height	F134116421233	200
	Eco flanged front locking device, set	height	F134116422204	5

### Rear Mounting Brackets

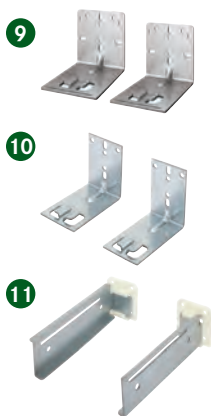

	Description	Item No.	PU
	(Must order separately)		
9	Rear mounting brackets, non-handed for 12"-21" slides, each	7950.VE300	300
10	Narrow rear mounting brackets, non-handed for 12"-21" slides, each	7951.VE300	300
11	Rear mounting sockets for 9" slides, set Set Includes: left and right sockets, (4) #M5 x 8 screw	00433-37	5

# Dynapro 19, Full Extension Slide, 2D

Integrated Soft-close with optional 3-dimensional adjustment for 19mm (3/4") drawer material

## Drawer Measurements

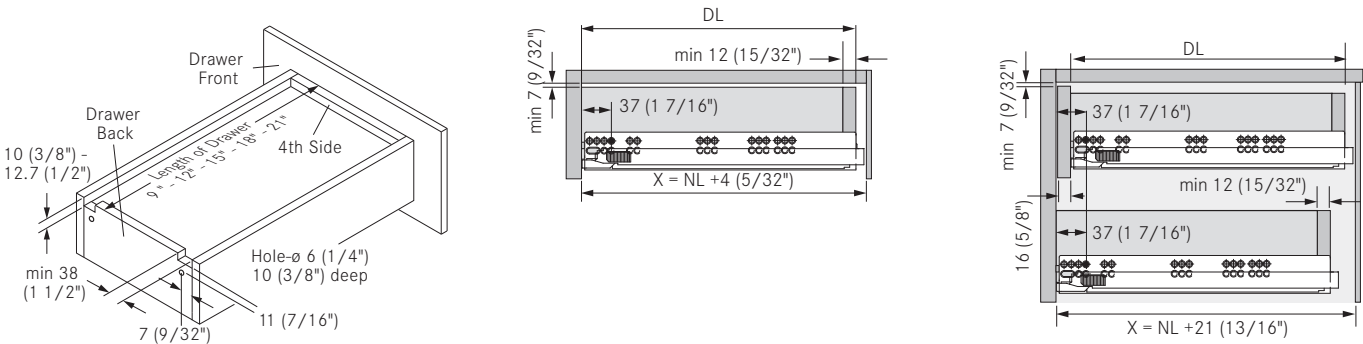

## Front Locking Device Installation

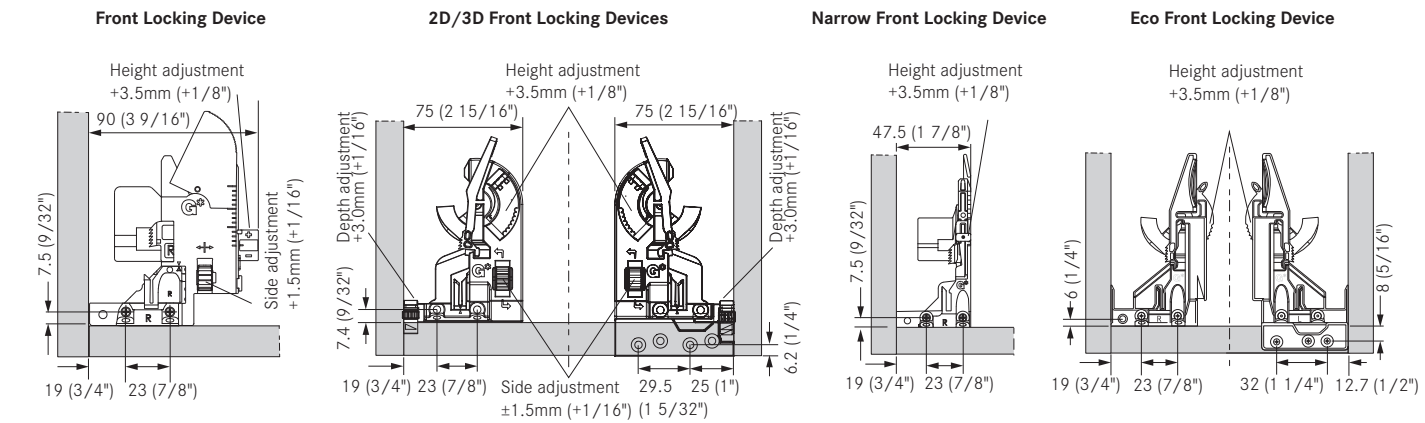

## Drawer Installation Dimensions

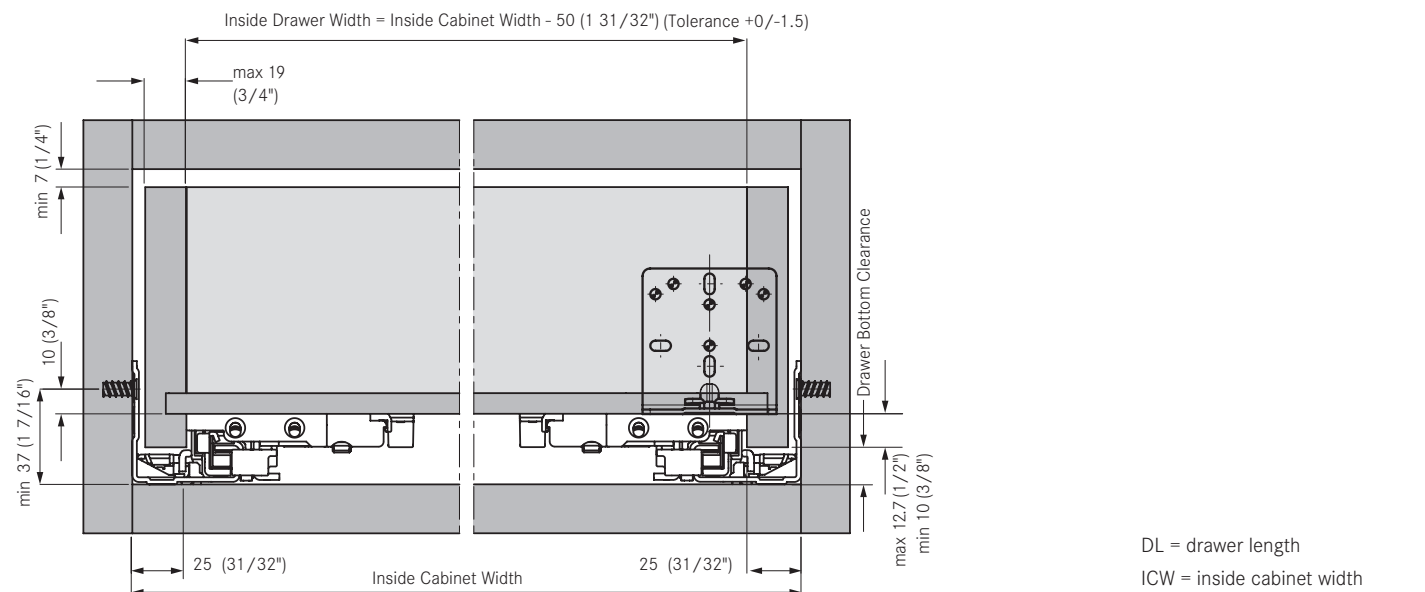

Minimum inside drawer width determined by front Locking device. See page 8.

DL = drawer length  
 ICW = inside cabinet width  
 IDW = inside drawer width  
 NL = nominal length  
 X = minimum installation depth

Drawer Material Thickness	19mm (3/4")
Dynamic Load	100 lb (45 kg)
Static Load	100 lb (45 kg)

**Mounting Position for Front Cabinet Profile** **Rear Bracket for Face Frame**

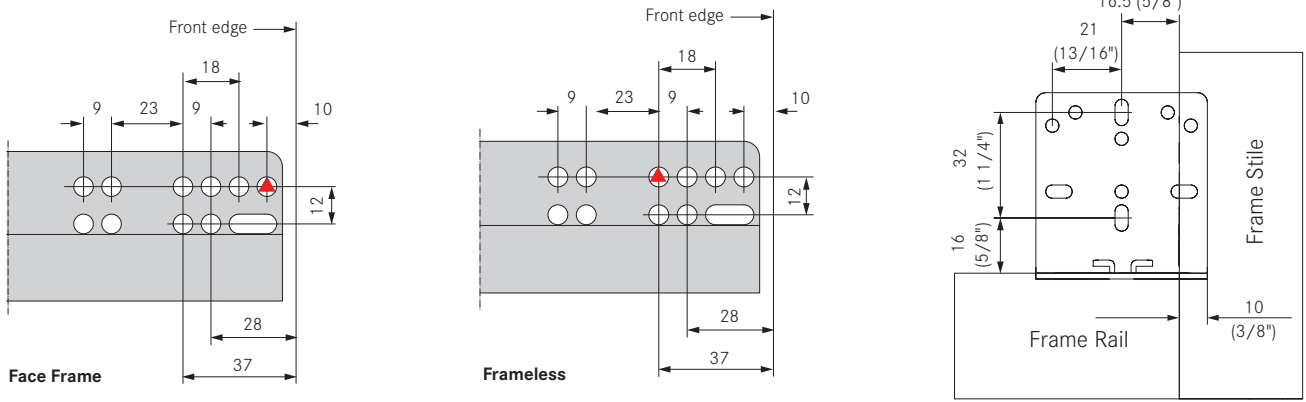

See page 9 for additional rear mounting brackets

**Cabinet Boring Specifications**

**Face Frame**

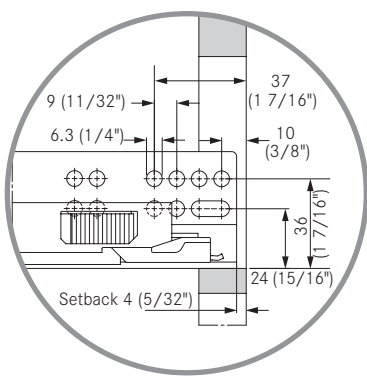
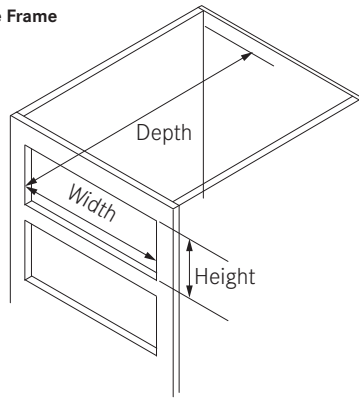

**Frameless**

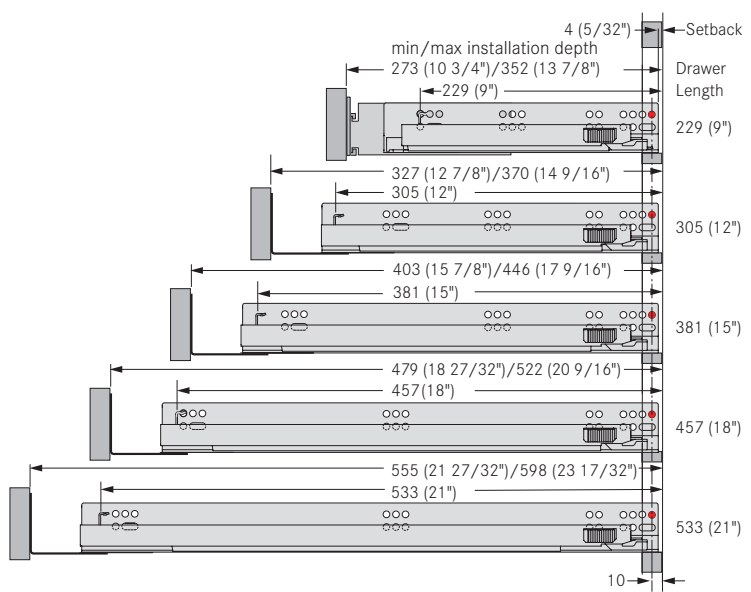
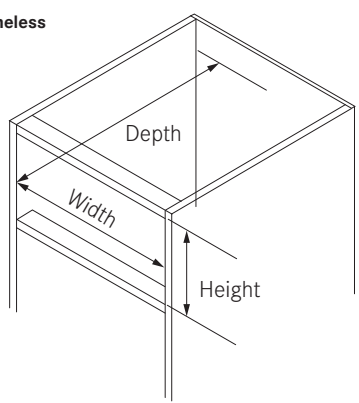

Pre-drilling recommended Ø2.5mm (3/32").

Note: The recommendations for screw placement are guidelines only. Installers need to ensure that the cabinet wall is adequate.

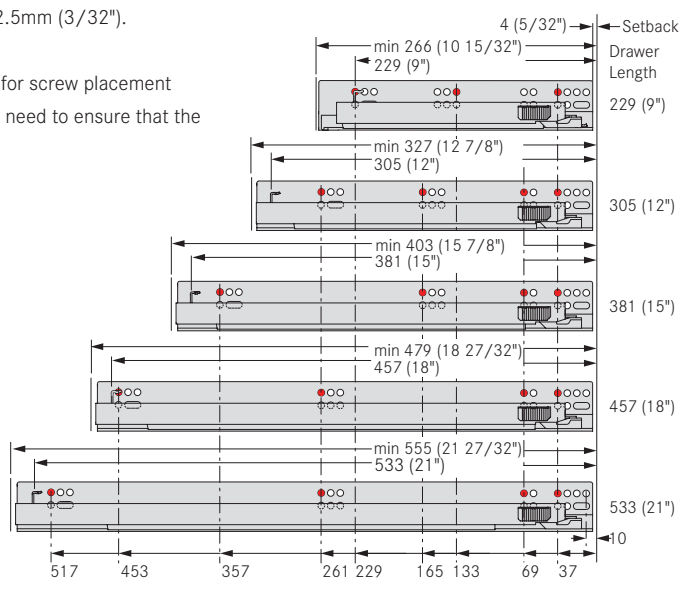

## Dynapro 19, Full Extension Slide, 3D

Integrated Soft-close with optional 4-dimensional adjustment for 19mm (3/4") drawer material



- Face frame or frameless applications from 16mm (5/8") up to 19mm (3/4") drawer material
- Full extension with a synchronized mechanism
- Fully enclosed soft-close liquid damping system
- Self-latching front locking devices have comfortable release levers for drawer removal and installation
- Height adjustment +3.5mm with suitable front locking device
- Side adjustment  $\pm 1.5$ mm with suitable front locking device
- Tilt adjustment +4.0mm
- Depth adjustment +3.0mm forward with suitable front locking device
- 100 lb load rating (45 kg)

### Dynapro 19 Full Extension Slide, 100 lb (45 kg)



Drawer Length	Nominal Length	Min Installation Depth	Max Installation Depth	Item No.	PU
229 (9")	262 (10 5/16")	273 (10 3/4")	352 (13 7/8")	<b>F130135022</b> 204	5
305 (12")	323 (12 23/32")	327 (12 7/8")	370 (14 9/16")	<b>F130135023</b> 604	5
381 (15")	399 (15 23/32")	403 (15 7/8")	446 (17 9/16")	<b>F130135024</b> 604	5
457 (18")	475 (18 11/16")	479 (18 27/32")	522 (20 9/16")	<b>F130135025</b> 604	5
533 (21")	551 (21 11/16")	555 (21 27/32")	598 (23 17/32")	<b>F130135026</b> 604	5

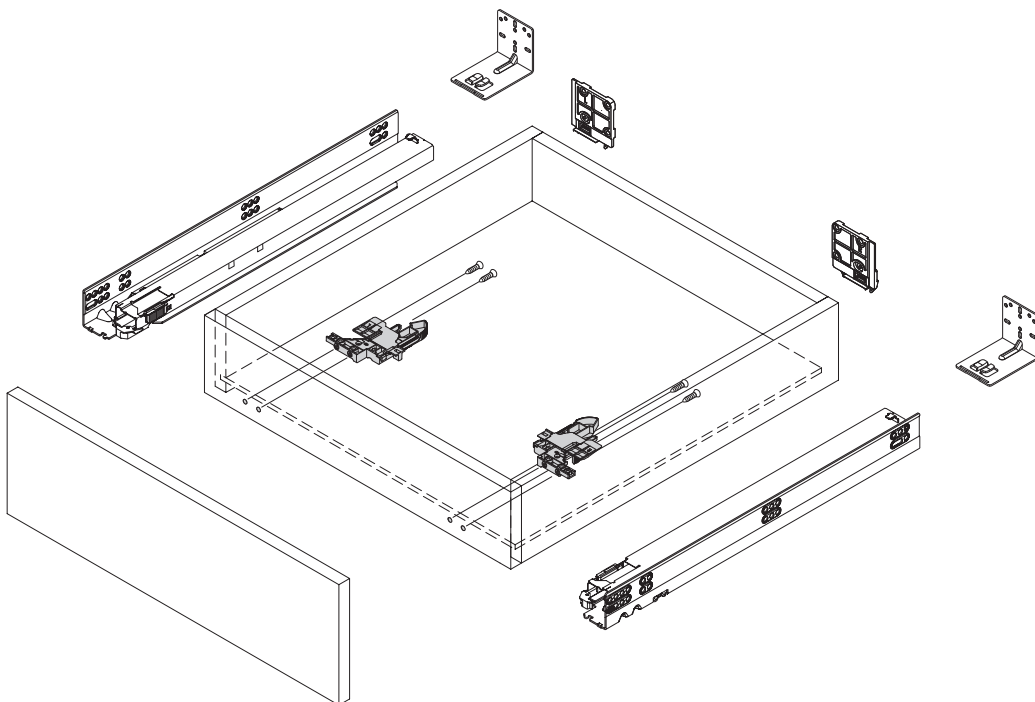

PU - Packaging unit



## Front Locking Devices

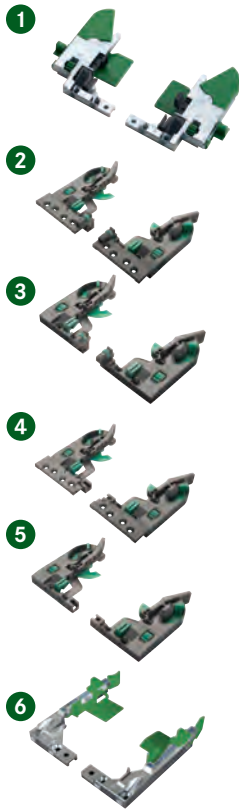

Description	Adjustments	Item No.	PU
(Must order separately)			
<b>1</b> Front locking device, left	height, side	<b>F134125000633</b>	200
Front locking device, right	height, side	<b>F134125001633</b>	200
Front locking device, set	height, side	<b>F134101400104</b>	5
<b>2</b> 3D Flanged front locking device, left	height, side, depth	<b>F134108942233</b>	200
3D Flanged front locking device, right	height, side, depth	<b>F134108943233</b>	200
<b>3</b> 3D Front locking device, left	height, side, depth	<b>F134108947233</b>	200
3D Front locking device, right	height, side, depth	<b>F134108948233</b>	200
<b>4</b> 2D Flanged front locking device, left	height, side	<b>F134108944233</b>	200
2D Flanged front locking device, right	height, side	<b>F134108945233</b>	200
<b>5</b> 2D Front locking device, left	height, side	<b>F134108950233</b>	200
2D Front locking device, right	height, side	<b>F134108951233</b>	200
<b>6</b> Narrow front locking device, left	height	<b>F134100699233</b>	200
Narrow front locking device, right	height	<b>F134100700233</b>	200

## Rear Mounting Brackets and Adjustment Adapters

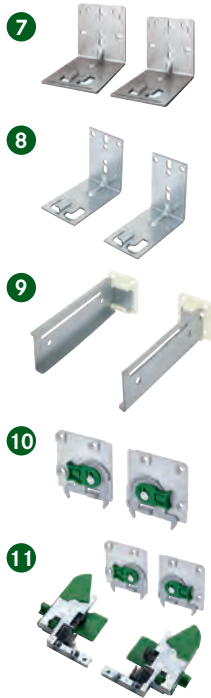

Description	Item No.	PU
(Must order separately)		
<b>7</b> Rear mounting brackets, non-handed for 12"-21" slides, each	7950.VE300	300
<b>8</b> Narrow rear mounting brackets, non-handed for 12"-21" slides, each	7951.VE300	300
<b>9</b> Rear mounting sockets for 9" slides, set Set Includes: left and right sockets, (4) #M5 x 8 screw	00433-37	5
<b>10</b> Tilt adjustment adapter, left	<b>F134125002233</b>	200
Tilt adjustment adapter, right	<b>F134125003233</b>	200
<b>11</b> Front locking device and adjustment adapter set Set Includes: Front locking device set and tilt adjustment adapter set	<b>F134125074517</b>	1

# Dynapro 19, Full Extension Slide, 3D

Integrated Soft-close with optional 4-dimensional adjustment for 19mm (3/4") drawer material

## Drawer Measurements

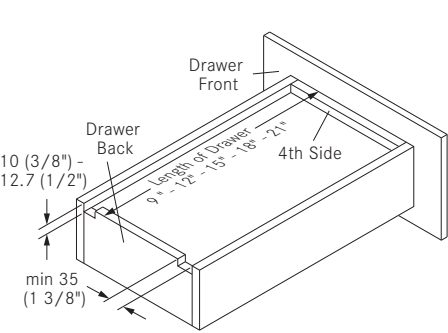

## Drawer

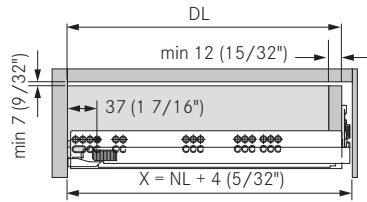

## Inset Roll-out Drawer

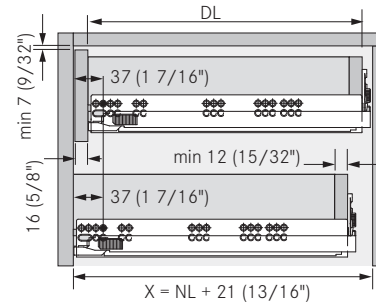

## Front Locking Device Installation

### Front Locking Device

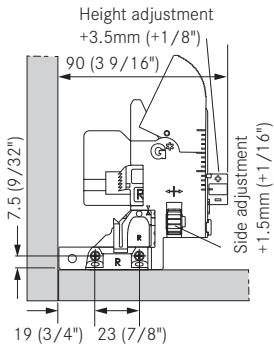

### 2D/3D Front Locking Devices

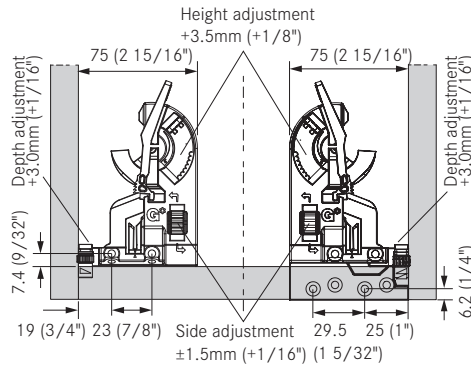

### Narrow Front Locking Device

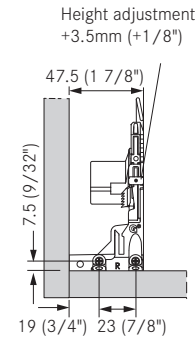

## Drawer Installation Dimensions

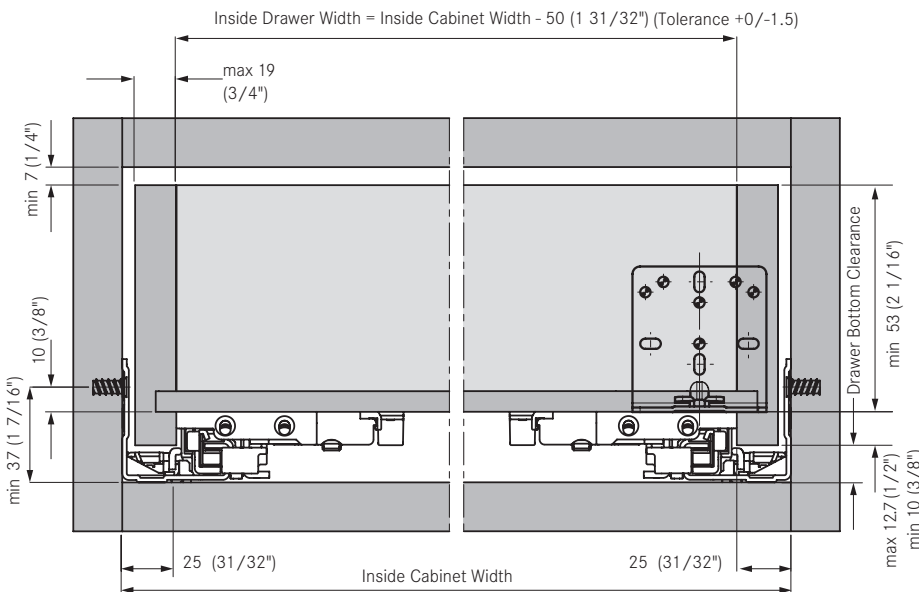

Minimum inside drawer width determined by front Locking device. See page 8.

## Tilt Adjustment Adapter Installation

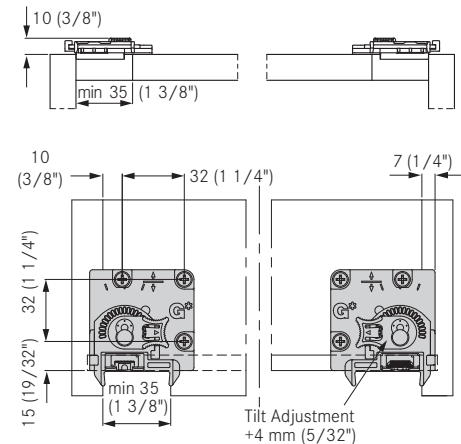

DL = drawer length  
ICW = inside cabinet width  
IDW = inside drawer width  
NL = nominal length  
X = minimum installation depth

Drawer Material Thickness	19mm (3/4")
Dynamic Load	100 lb (45 kg)
Static Load	100 lb (45 kg)

**Mounting Position for Front Cabinet Profile** **Rear Bracket for Face Frame**

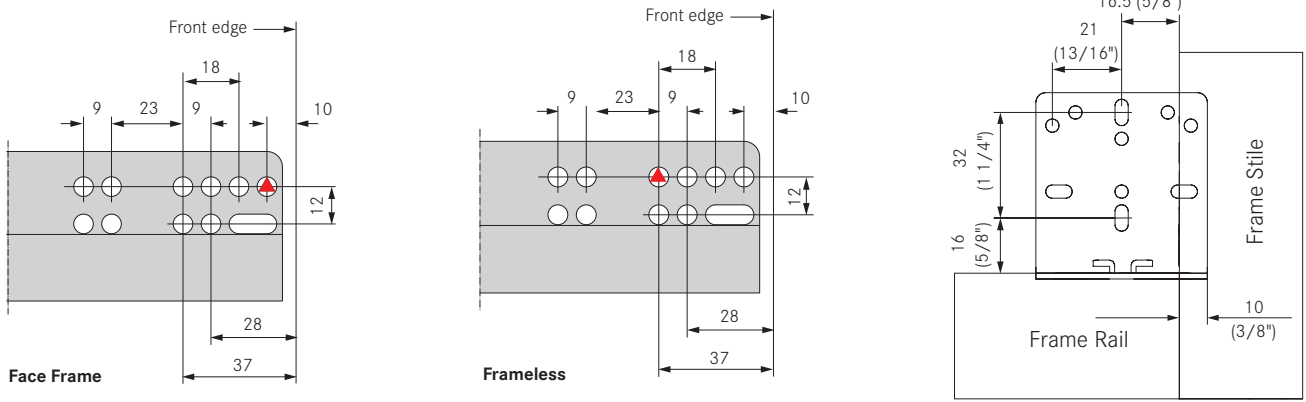

See page 9 for additional rear mounting brackets

**Cabinet Boring Specifications**

**Face Frame**

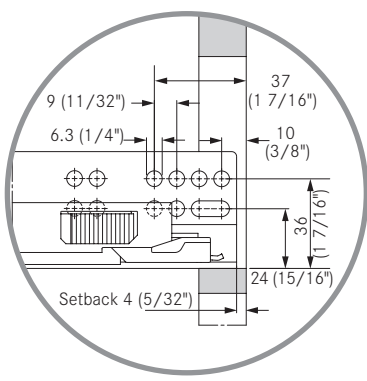
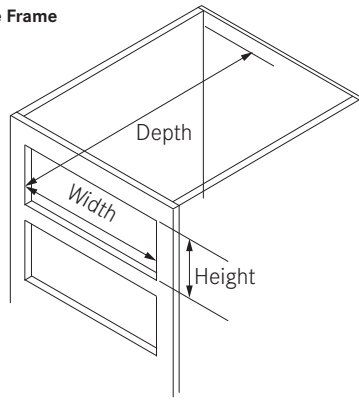

**Frameless**

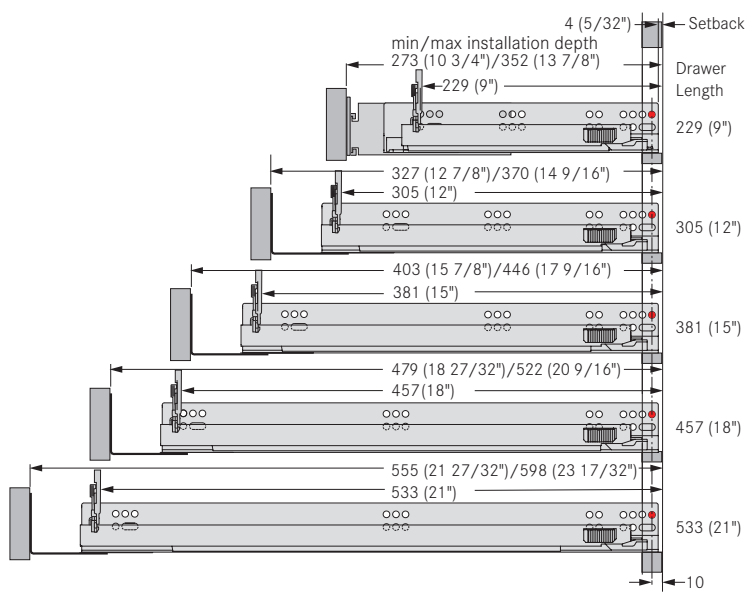
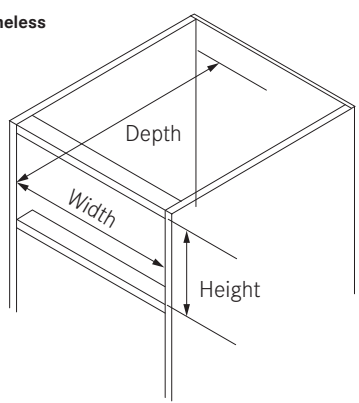

Pre-drilling recommended  $\varnothing 2.5\text{mm}$  (3/32").

Note: The recommendations for screw placement are guidelines only. Installers need to ensure that the cabinet wall is adequate.

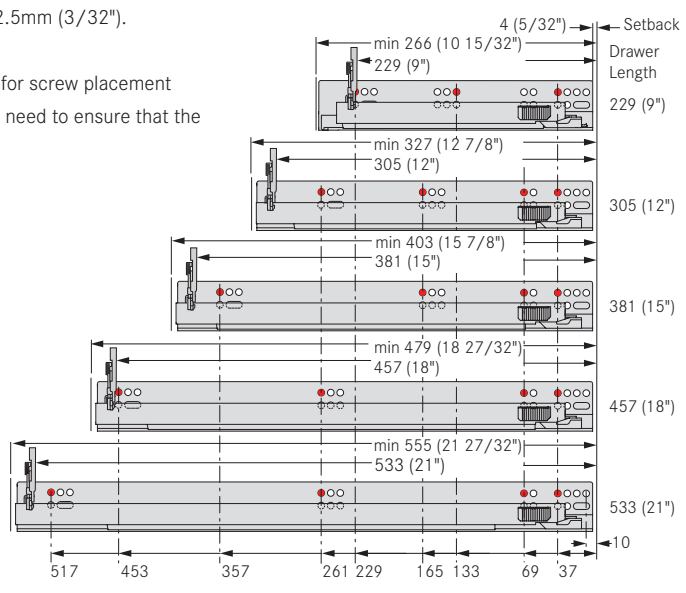

# Dynapro 19, Heavy Duty and Extended Length Slide, 3D

Integrated Soft-close with optional 4-dimensional tilt adjustment for 19mm (3/4") drawer material



- Face frame or frameless applications from 16mm (5/8") up to 19mm (3/4") drawer material
- Face frame application must be blocked out
- Full extension with a synchronized mechanism
- Fully enclosed soft-close liquid damping system
- Self-latching front locking devices have comfortable release levers for drawer removal and installation
- Height adjustment +3.5mm
- Side adjustment ±1.5mm
- Tilt adjustment +4.0mm
- Depth adjustment +4.5mm (optional)
- 132 lb load rating (60 kg) heavy duty
- 110 lb load rating (50 kg) extended length

## Dynapro 19 Full Extension Slide, 132 lb (60 kg) and 110 (50 kg)



Drawer Length	Nominal Length	Min Installation Depth	Item No.	PU
457 (18")	475 (18 11/16")	479 (18 27/32")	<b>F130135027604</b>	5
533 (21")	551 (21 11/16")	555 (21 27/32")	<b>F130135028604</b>	5
610 (24")	628 (24 23/32")	632 (24 7/8")	<b>F130135427604</b>	5
686 (27")*	704 (27 23/32")	708 (27 7/8")	<b>F130136064604</b>	5
762 (30")*	780 (30 23/32")	784 (30 7/8")	<b>F130135029604</b>	5

\*Extended lengths, 110 lb (50 kg)

Note: Heavy duty and extended length slides must be blocked out for face frame application.

## Front Locking Devices and Adjustment Adapters

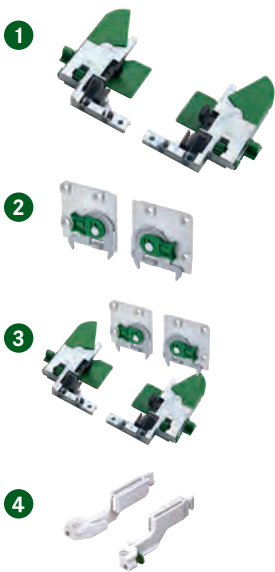

Description	Adjustments	Item No.	PU
(Must order separately)			
① Front locking device, left	height, side	<b>F134125000633</b>	200
Front locking device, right	height, side	<b>F134125001633</b>	200
Front locking device, set	height, side	<b>F134101400104</b>	5
② Tilt adjustment adapter, left		<b>F134125002233</b>	200
Tilt adjustment adapter, right		<b>F134125003233</b>	200
③ Front locking device and adjustment adapter set		<b>F134125074517</b>	1
Set Includes: Front locking device set and tilt adjustment adapter set			
④ Depth adjustment for drawer front, left and right, set, optional		<b>F134101002104</b>	5

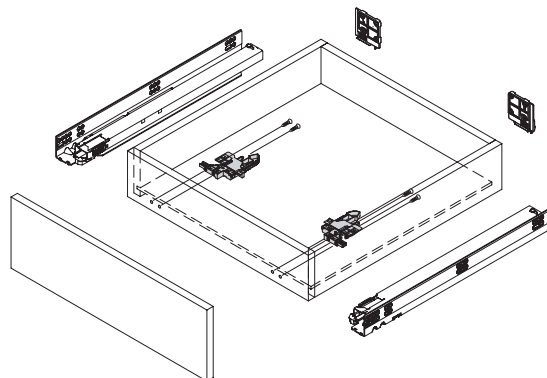

PU - Packaging unit

Drawer Material Thickness	19mm (3/4")
Dynamic Load	* 132 lb (60 kg)
Static Load	* 150 lb (70 kg)
Adjustment (depth optional)	Tilt & Depth

**Drawer Measurements      Drawer      Inset Roll-out Drawer**

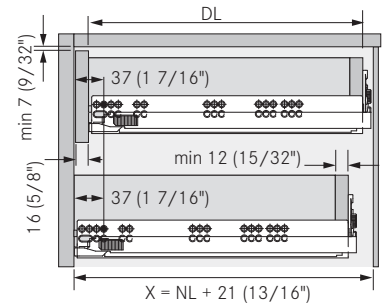
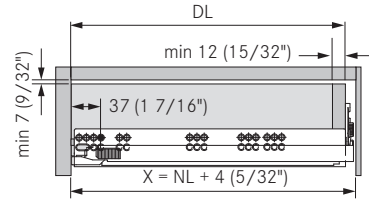
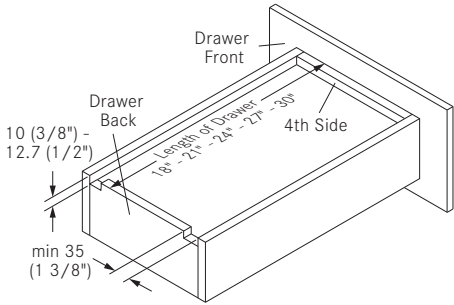

**Front Locking Device Installation      Drawer Installation Dimensions      Mounting Position for Front Cabinet Profile**

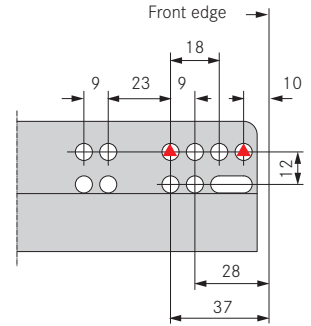
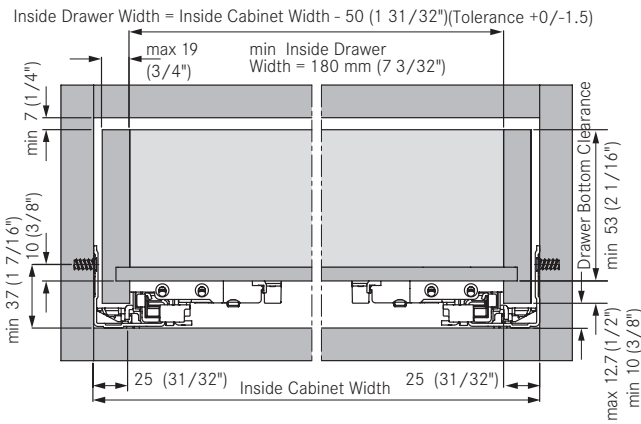
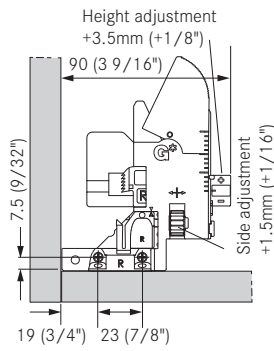

**Tilt Adjustment Adapter Installation      Cabinet Boring Specifications**

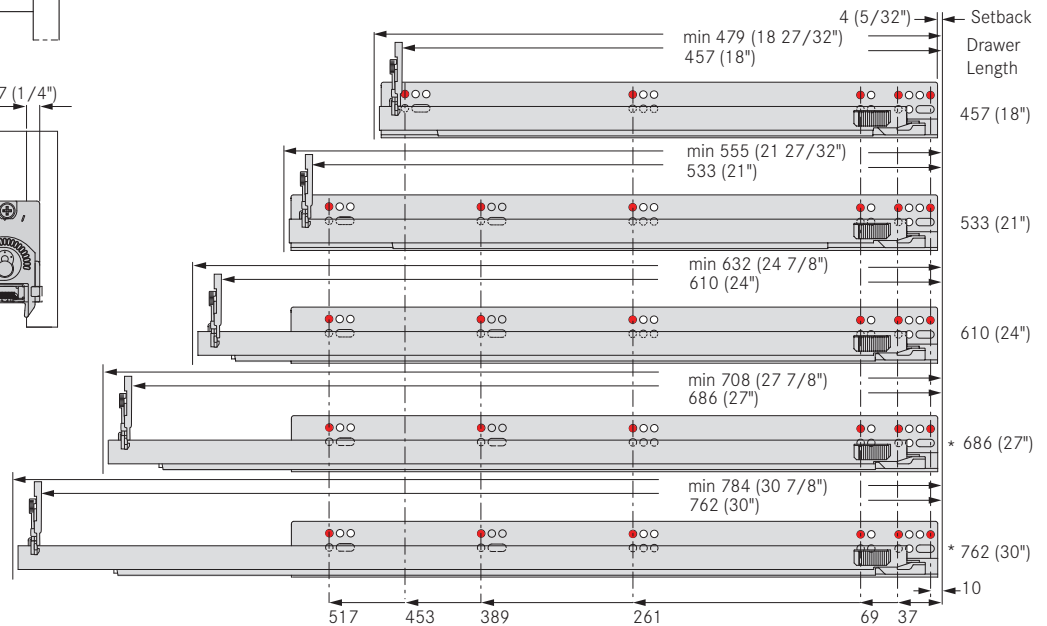
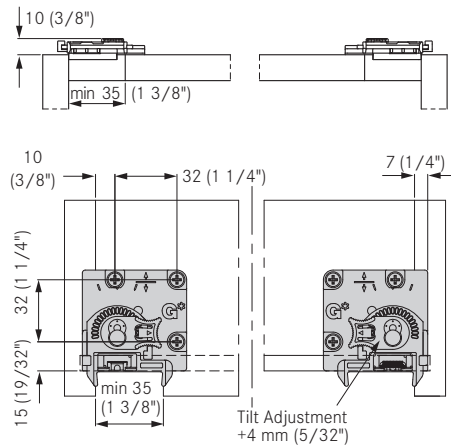

Pre-drilling recommended  $\varnothing 2.5\text{mm}$  (3/32").  
 Note: The recommendations for screw placement are guidelines only. Installers need to ensure that the cabinet wall is adequate.

DL = drawer length  
 ICW = inside cabinet width  
 IDW = inside drawer width  
 NL = nominal length  
 X = minimum installation depth

\* 110 lb dynamic load and 125 lb static load for extended lengths.

All dimensions in millimeters.



# Dynapro Tipmatic Soft-close

For 19mm (3/4") drawer material



- Face frame or frameless applications from 16mm (5/8") up to 19mm (3/4") drawer material
- Mechanical opening system for handle-free fronts
- Combines Tipmatic function with Soft-close damping
- Tool-free assembly of the Tipmatic Soft-close unit
- One unit for nominal lengths 305mm (12") up to 762mm (30")
- 3-tier adjustment for the opening force
- Wide activation zone due to synchronization bar
- Works with all Dynapro types including heavy duty
- Works with Vionaro drawers
- Dynapro Tipmatic Soft-close works with all Dynapro front locking devices
- For drawer widths up to 1168mm (46")

## Tipmatic Soft-close

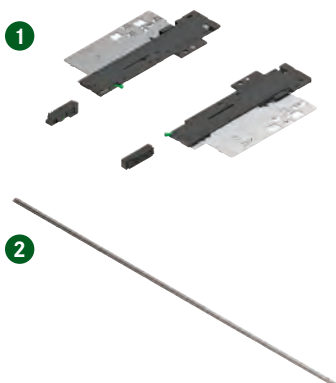

Description	Item No.	PU
(Must order separately)		
1 Tipmatic Soft-close set, unit and activator	<b>F134109323607</b>	10
2 Tipmatic synchronization bar - cut to length, 952mm (37 1/2")	<b>F134109410207</b>	10

Note: Tipmatic Soft-close does not work with 9" slides.

Drawer Length	Nominal Length	Min Inst. Depth	Max Inst. Depth
305 (12")	323 (12 23/32")	327 (12 7/8")	370 (14 9/16")
381 (15")	399 (15 23/32")	403 (15 7/8")	446 (17 9/16")
457 (18")	475 (18 11/16")	479 (18 27/32")	522 (20 9/16")
533 (21")	551 (21 11/16")	555 (21 27/32")	598 (23 17/32")
610 (24")	628 (24 23/32")	632 (24 7/8")	-
686 (27")	704 (27 23/32")	708 (27 7/8")	-
762 (30")	780 (24 23/32")	784 (30 7/8")	-

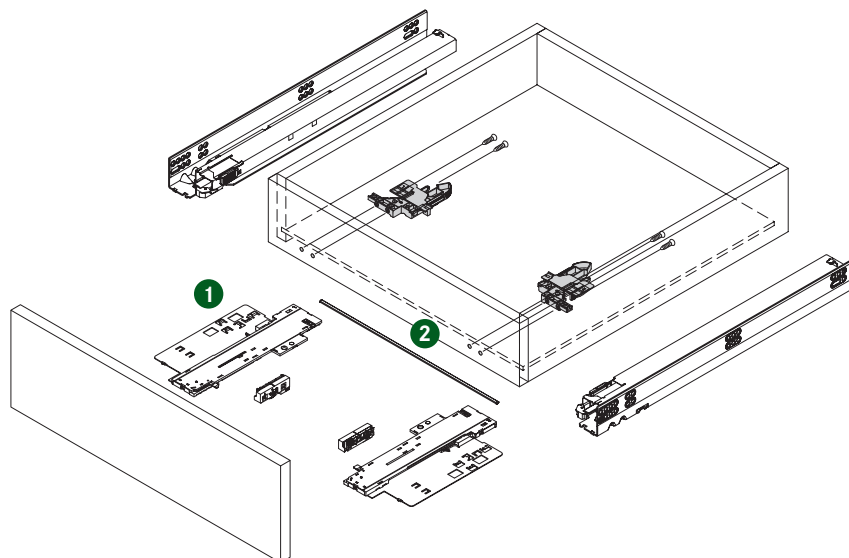

PU - Packaging unit

**Drawer Measurements** **Drawer Installation Dimensions**

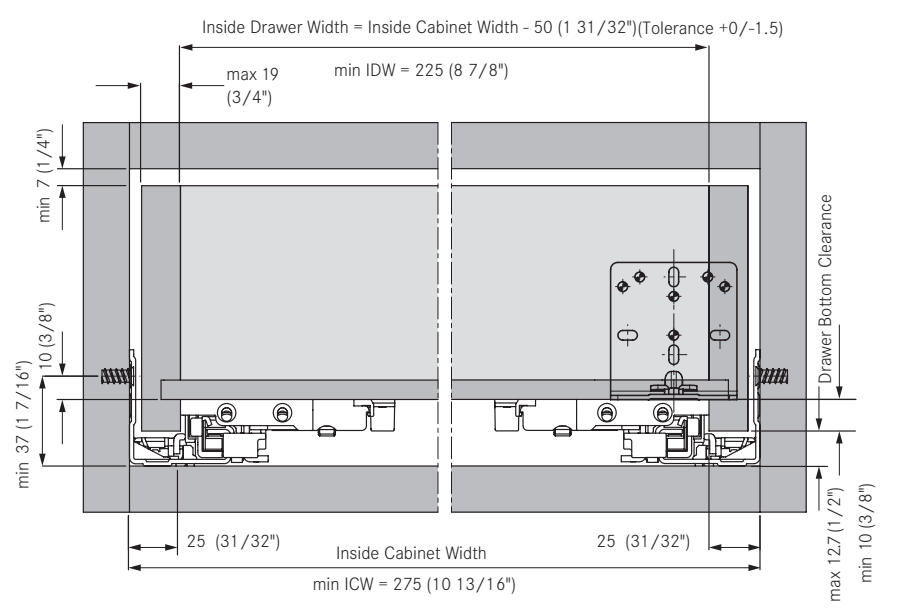
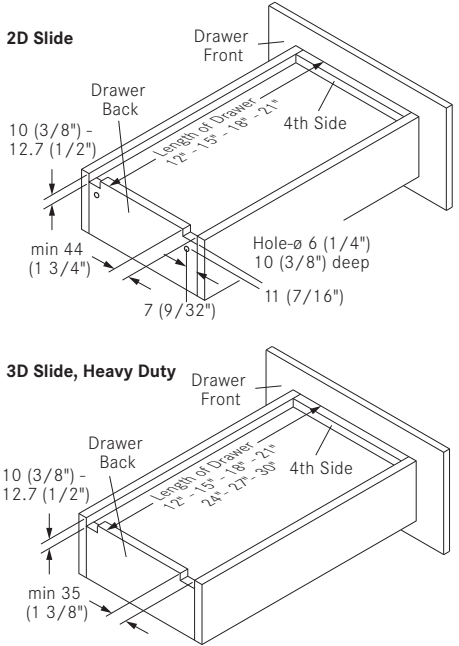

**Synchronization Bar** **Drawer** **Inset Roll-out Drawer**

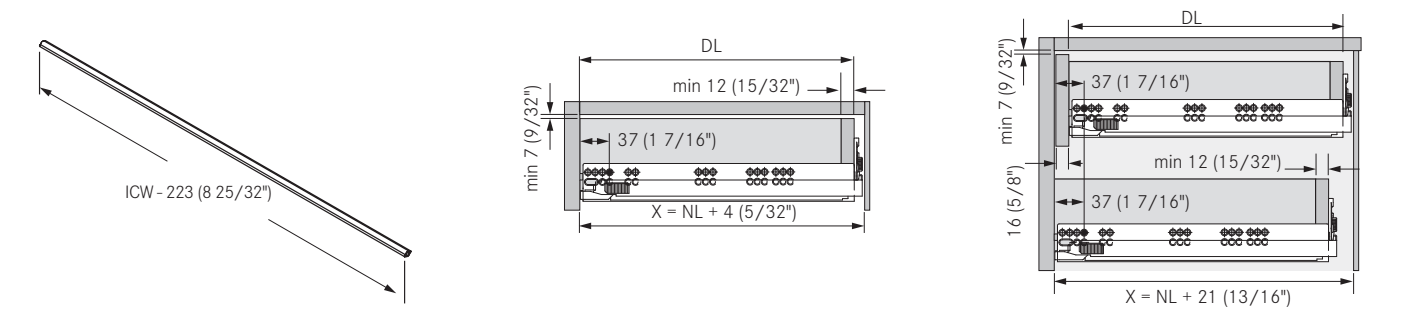

**Position of the Synchronization Bar** **Tilt Adjustment Adapter Installation**

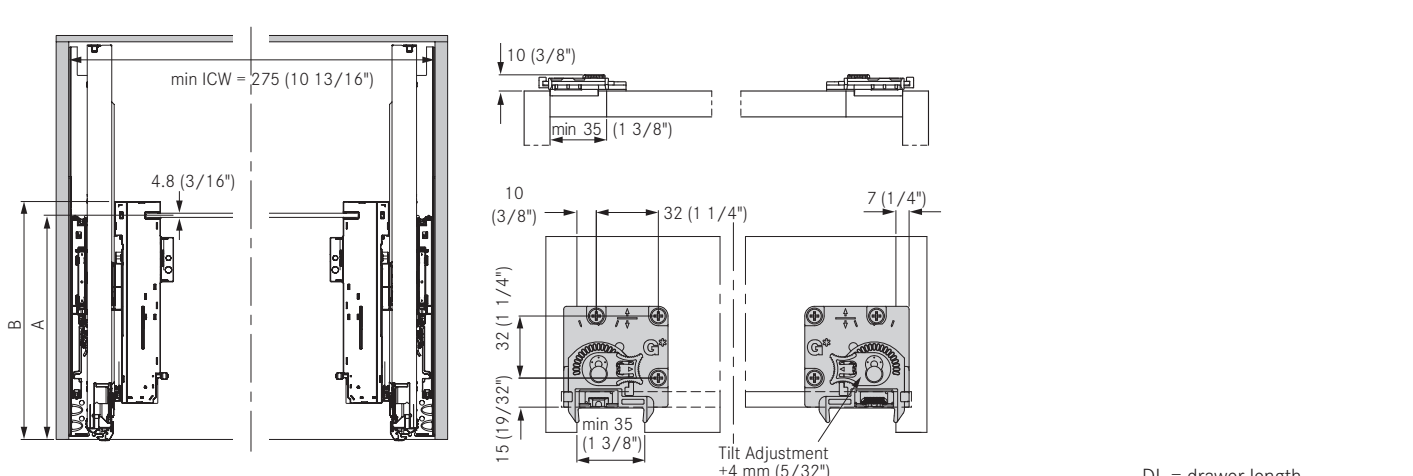

Drawer Length	A	B
<b>305 (12")</b>	261 (10 9/32")	278 (10 15/16")
<b>381 - 762 (15 - 30")</b>	296 (11 21/32")	313 (12 5/16")

DL = drawer length  
 ICW = inside cabinet width  
 IDW = inside drawer width  
 NL = nominal length  
 X = minimum installation depth

# Accessories and Assembly Aids

## Dynapro

### Assembly Aids

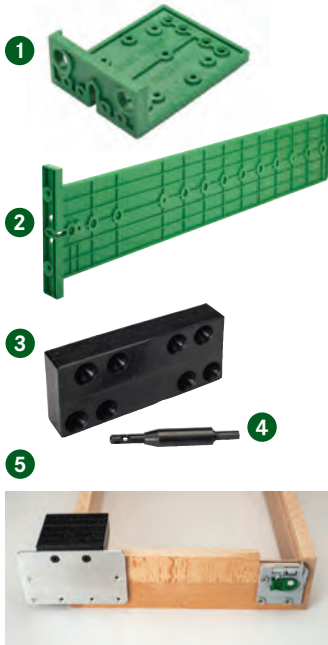

Drawer Drilling Template for drilling front locking devices, drawer hole hook, or adjustment adapters

The non-flanged FLD drilling jig is used for mounting non-flange front locking devices to the drawer box for Dynapro, Elite Plus and Maxcess.

The GRASS centering drill bit is used for pre-drilling countersink wood screws, Ø 2.5mm

The Dynapro rear tilt adapter jigs are designed for locating the position of the tilt adapter on the drawer box back. The jigs are available for 16mm and 19mm drawer material.

Description	Item No.	PU
1 Drilling template - Drawer	F146109874299	1
2 Drilling template - Cabinet member	F146101348507	1
3 Non-flanged FLD Drilling Jig	00004	1
4 Centering drill bit	35692-01	1
5 Dynapro Rear Tilt Adapter Drilling Jig 16mm	00005	1
Dynapro Rear Tilt Adapter Drilling Jig 19mm	00006	1

### Inset Bracket Set



- For face frame inset applications with Dynapro
- Works with all inset applications
- Bracket mounts behind the face frame, minimum 12.7mm (1/2") frame offset required
- Slide attaches easily with one screw
- Includes guide markings for proper setback



Description	Item No.	PU
Inset bracket set	13901-37	1
Inset bracket set	13901-08	50

#### Polybag set consists of:

- 2 - Universal Inset Bracket ABS Brown
- 2 - 8 X 32 Tapped Insert for Inset bracket
- 4 - #7 X 2" mounting screws
- 2 - #8 - 32 X 1/2" Machine Screw FHP
- 1 - Instructions

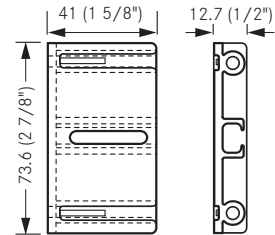

### Interior Drawer Bracket



- Used to mount slides to a cabinet bottom or shelf for interior roll out trays.
- Works with Dynapro and Nova Pro Scala drawer slides

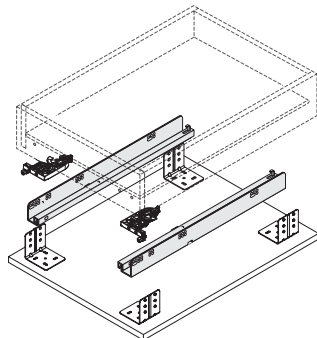

Description	Item No.	PU
Interior drawer bracket, set	00443-40	25

#### Set consists of:

- 4 - non-handed, zinc plated, steel brackets
- 8 - M4 screws to attach slides to brackets
- 8 - #8 x 5/8" PHP screws to mount brackets to cabinet

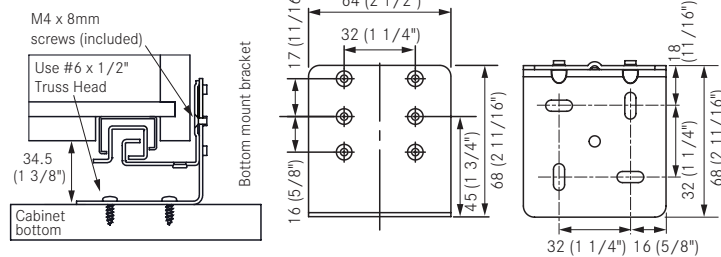

PU - Packaging unit

## Dynapro

### Screws

#### Euro Screw, Nickel-plated



Description	Item No.	PU
Euro Screw 11mm (7/16") Pozi	499.360.61.1015	500
Euro Screw 13mm (1/2") Pozi	499.360.61.3015	500

#### Wood Screw, Nickel-plated



Description	Item No.	PU
#6 x 5/8" FHP, NI	81001-43	500
#6 x 3/4" FHP, NI	81003-43	500

### Bumper Pads

#### Bumper Pads, Self-adhesive



Description	Item No.	PU
Bumper pad, clear, 2.5mm	63407-99	288
Bumper pad, clear, 2.5mm	63407-47	7200

#### AirSoft Bumper Pads, Self-adhesive



Description	Item No.	PU
AirSoft Bumper pad, clear, 5mm	63481-43	500
AirSoft Bumper pad, clear, 5mm	63483-30	5000

#### Bumper Pads, Self-adhesive



Description	Item No.	PU
Bumper pad, clear, 7mm	630.000.03.0750	1088
Bumper pad, clear, 10mm	630.000.03.1050	1050
Bumper pad, clear, 12mm	630.000.02.1250	5000

#### Bumper Pads, Self-adhesive



Description	Item No.	PU
Bumper pad, clear, 3mm	31002-43	500
Bumper pad, clear, 1.5mm	31004-43	500

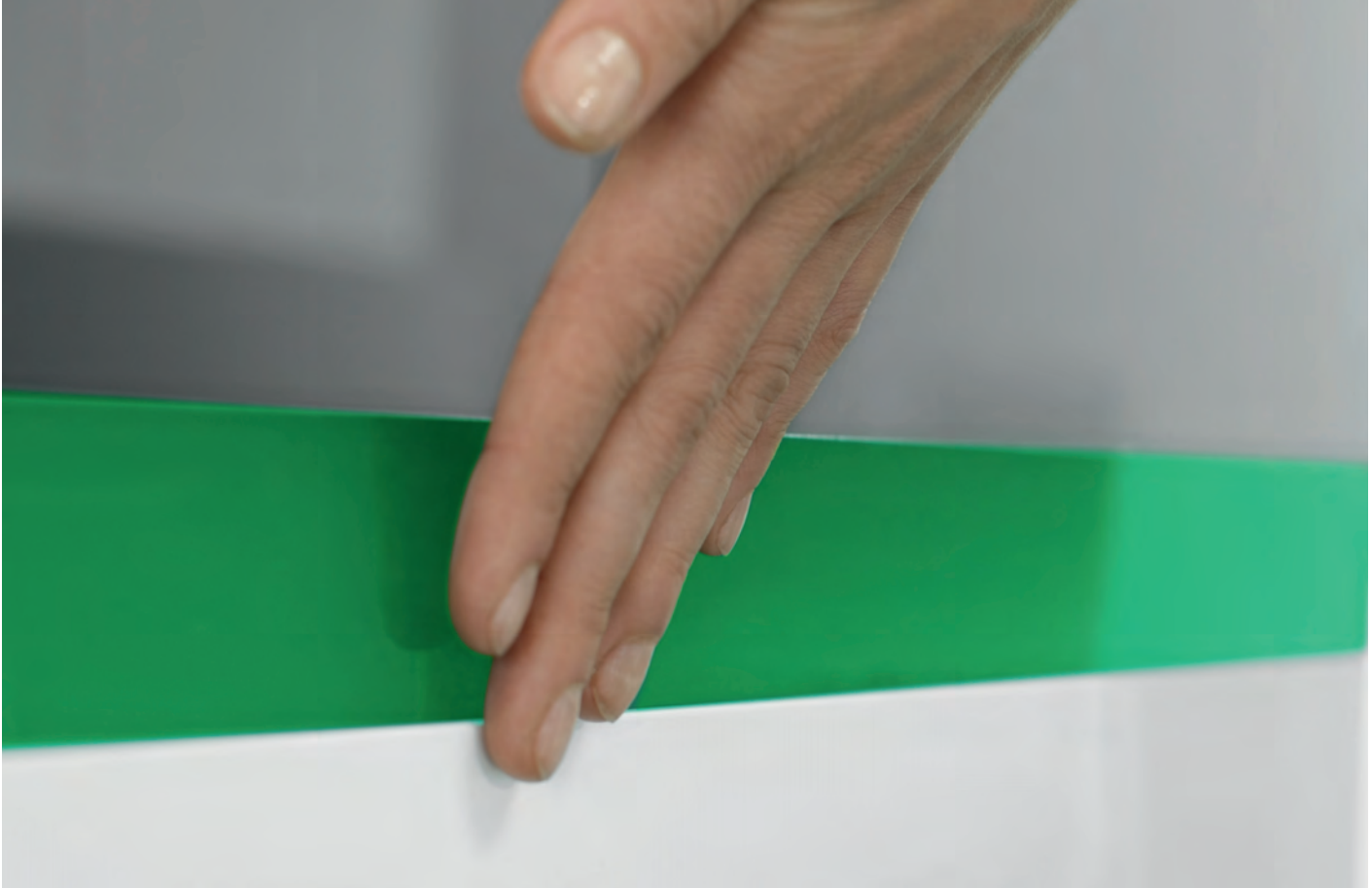

Sensomatic combines handle-free opening with the ever popular Soft-closing action

**Just tap anywhere on the drawer front and the drawer opens automatically.**

The Sensomatic is an electro-mechanical opening system that works with the Dynapro slide system. A simple installation process creates a superior drawer system.



Versatile, Efficient, Exciting:  
 Lightly touch the front panel and the  
 drawers will open as if by magic.  
 Fully automatic, electrically powered.

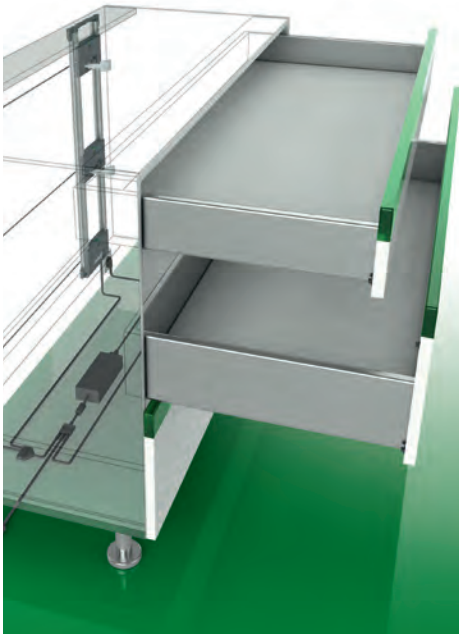

## SENSOMATIC OPENING SYSTEM

Sensomatic, an electro-mechanical opening system that can be activated by a light touch anywhere on the surface of the drawer front. At the touch, the drawers glide open in one smooth motion.

With the touch-sensitive Sensomatic device all you need is a gentle touch anywhere on the drawer front to automatically open the drawers. The action is steady and precise. The perfect movement for today's functional requirements.

Sensomatic together with Soft-close offers all the advantages of handle free opening with the elegance and functionality of a soft-closing action. These functions together guarantee your operating convenience at the highest level.

Sensomatic is extremely efficient in regard to power consumption and occupied space. The Sensomatic needs only one drive unit for cabinet widths up to 47 1/4" (1200mm) regardless of the weight. Accessories such as wire baskets, trash can receptacles, or roll out trays can be fitted with the Sensomatic system without modification. It has never been easier to open a drawer and - never easier to close a drawer.



# Sensomatic

## Standard cabinet with horizontal wooden stretcher

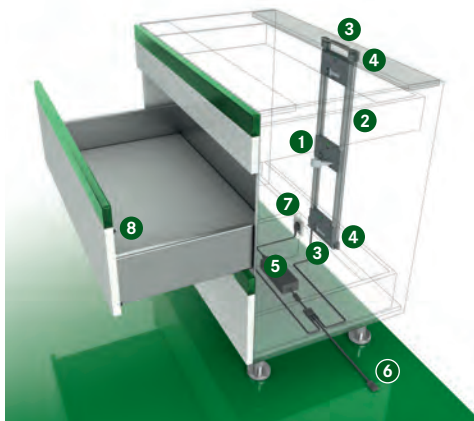

- Electro-mechanical opening system
- Sensomatic works with any Dynapro drawer design
- Activated by a light touch anywhere on the drawer front
- One drive unit for cabinets widths up to 47 1/4" (1200mm)
- Soft-closing action pulls the drawer closed
- Ideal for accessories such as wire baskets, waste bins, or roll-out trays
- Full extension for maximum access to drawer contents

### 1 Opening Unit



	Item No.	PU
For Dynapro	<b>F121100268607</b>	10

PU - 10 pieces, individually packaged

### 2 Frame Sides, Including Frame Side Cable



Length	Item No.	PU
750mm	<b>F121100285207</b>	10
1170mm	<b>F121100286207</b>	10

PU - 10 pairs

### 3 Frame Connector



	Item No.	PU
Frame connector	<b>F121100282211</b>	20

### 4 Fixing Bracket



	Item No.	PU
Fixing bracket	<b>F121100270211</b>	1

### 5 Power Supply Unit



	Item No.	PU
Power supply unit	<b>F121100269607</b>	10

PU = 10 pieces, individually packaged

One power supply operates up to 30 opening units

### 6 Connection Cable with 2-way-adapter



Length	Item No.	PU
1000mm	<b>F121100289207</b>	10
1600mm	<b>F121100290207</b>	10
2000mm	<b>F121100291207</b>	10

### 7 Power Cord, 1.8 m (6')



Type of plug	Item No.	PU
Power cord (USA, CA)	<b>F120069760207</b>	10

### 8 Spring-loaded Front Bumper



Ø 5mm	Item No.	PU
Front gap 2.2mm	<b>F121100294223</b>	100
Front gap 3mm	<b>F121100295223</b>	100

PU - Packaging unit

## Mounting Dimensions

Fixing brackets positioned at top and bottom

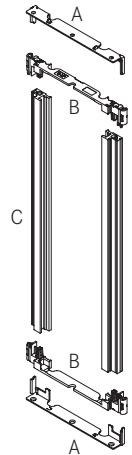
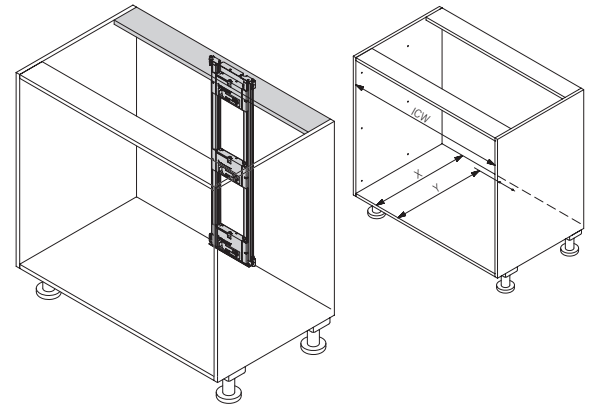
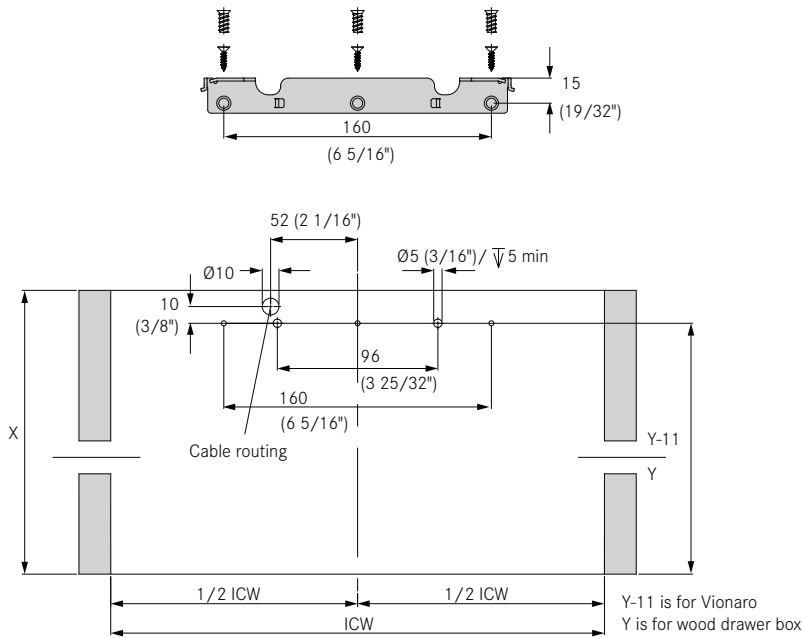

Mounting dimensions Dynapro	X	Y	Min ICW
Wood back panel	NL + 15 (19/32")	NL	312 (12 9/32")

## Legend

### Position of Opening Unit for Dynapro

### Position of Front Bumper

- A = fixing bracket used at top and bottom
- B = frame connector
- C = frame sides
- ICW = inside cabinet width
- NL = nominal length of cabinet slide
- X = min installation depth
- Y = depth of hole pattern

- FSL = frame side length
- ICH = inside cabinet height

- FH = front height
- FO = front overlay

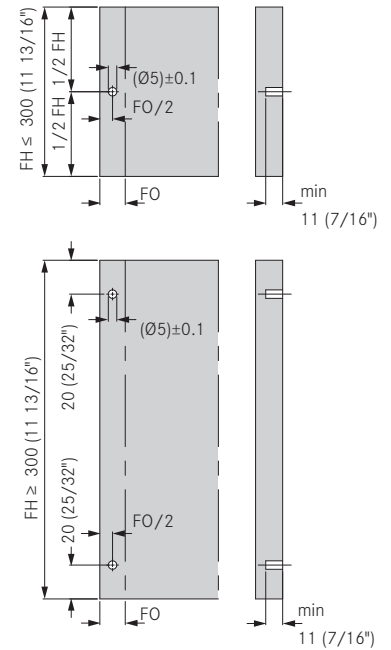
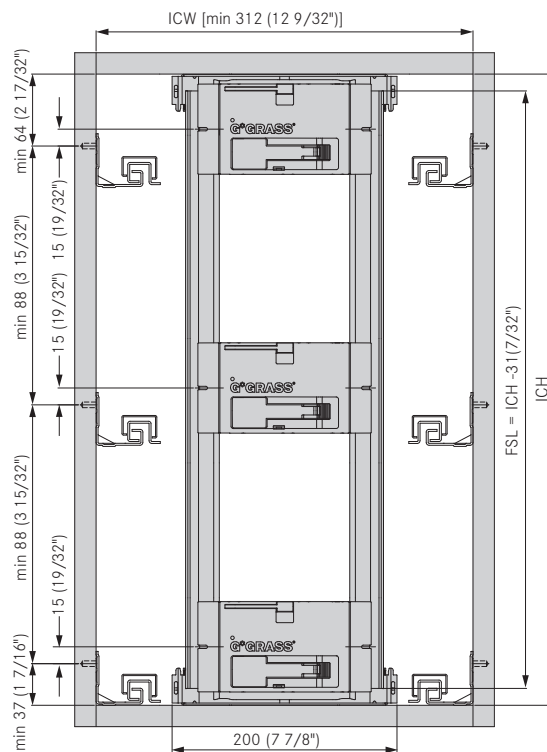

When mounting the heavy-duty slide (132 lbs.), it is necessary to insert 4 front bumpers into the drawer front.

# Sensomatic for Dynapro

## Standard cabinet with vertical wooden stretcher

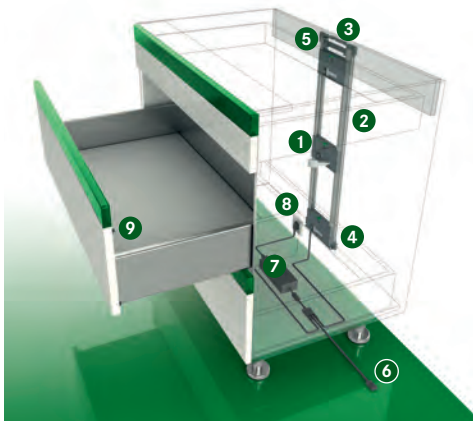

- Electro-mechanical opening system
- Sensomatic works with any Dynapro drawer design
- Activated by a light touch anywhere on the drawer front
- One drive unit for cabinets widths up to 47 1/4" (1200mm)
- Full extension for maximum access to drawer contents
- Soft-closing action pulls the drawer closed
- Ideal for accessories such as wire baskets, waste bins, or roll-out trays

### 1 Opening Unit



	Item No.	PU
For Dynapro	<b>F121100268607</b>	10
PU - 10 Pieces, individually packaged		

### 2 Frame Sides, including Frame Side Cable



Length	Item No.	PU
750mm	<b>F121100285207</b>	10
1170mm	<b>F121100286207</b>	10
PU - 10 Pairs		

### 3 Frame Connector



	Item No.	PU
Frame connector	<b>F121100282211</b>	20

### 4 Fixing Bracket



	Item No.	PU
Fixing bracket	<b>F121100270211</b>	1

### 5 Rear-mount Fixing Brackets



	Item No.	PU
Flush mount	<b>F121100275207</b>	10

### 6 Connection Cable with 2-way-adapter



Length	Item No.	PU
1000mm	<b>F121100289207</b>	10
1600mm	<b>F121100290207</b>	10
2000mm	<b>F121100291207</b>	10

### 7 Power Supply Unit



	Item No.	PU
Power supply unit	<b>F121100269607</b>	10
PU = 10 pieces, individually packaged		
One power supply operates up to 30 opening units		

### 8 Power Cord, 1.8 m (6')



Type of plug	Item No.	PU
Power cord (USA, CA)	<b>F120069760207</b>	10

### 9 Spring-loaded Front Bumper



Ø 5mm	Item No.	PU
Front gap 2.2mm	<b>F121100294223</b>	100
Front gap 3mm	<b>F121100295223</b>	100

PU - Packaging unit

## Mounting Dimensions

Fixing bracket positioned at bottom

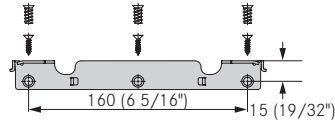
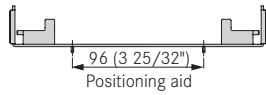

Rear-mount fixing bracket (flush mount)

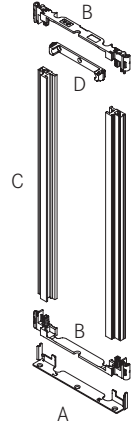
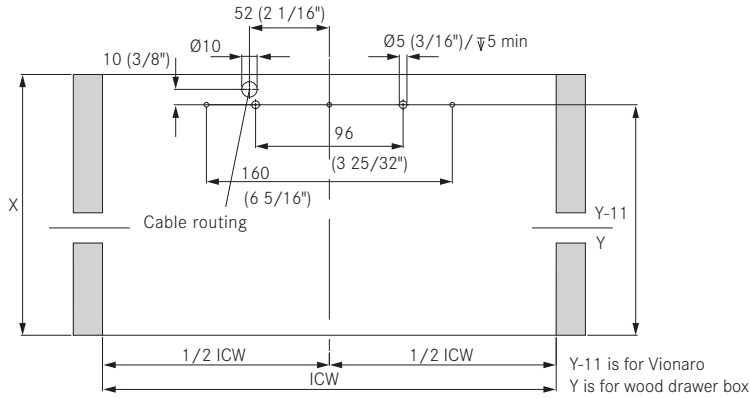
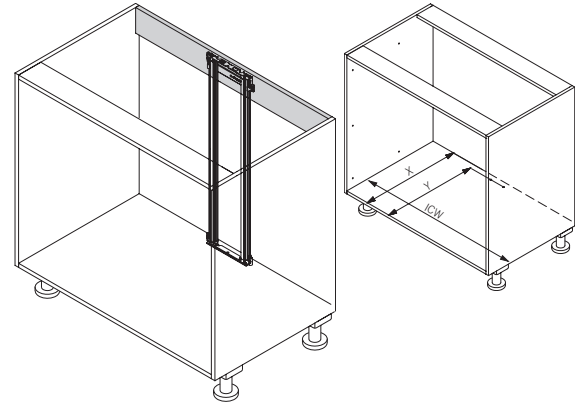
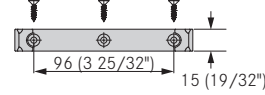

### Mounting dimensions Dynapro

	X (inside)	Y	Min ICW
Wood back panel	NL + 15 (19/32")	NL	312 (12 9/32")

## Legend

### Position of Opening Unit for Dynapro

### Position of Front Bumper

- A = fixing bracket used at top and bottom
- B = frame connector
- C = frame sides
- D = Rear mount fixing bracket, flush
- ICW = inside cabinet width
- NL = nominal length of cabinet slide
- X = min installation depth
- Y = depth of hole pattern

- FSL = frame side length
- ICH = inside cabinet height

- FH = front height
- FO = front overlay

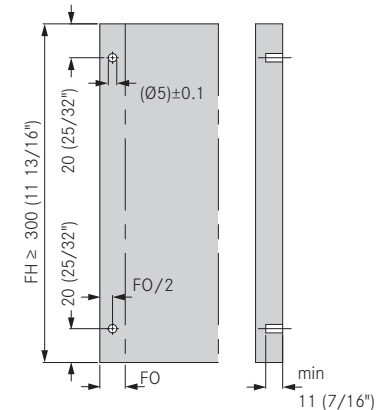
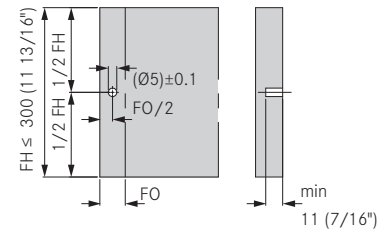
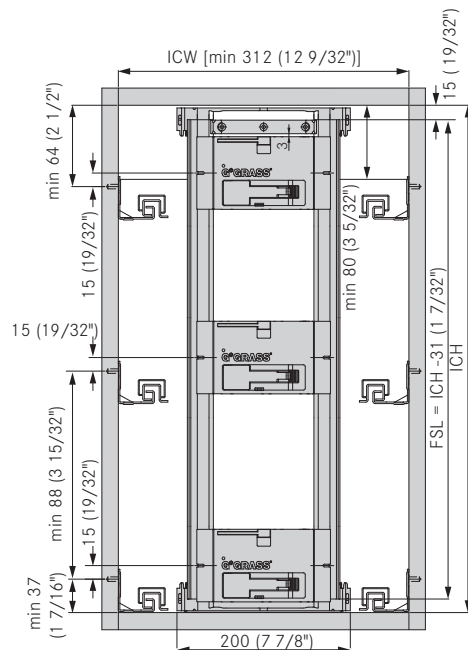

When mounting the heavy-duty slide (132 lbs.), it is necessary to insert 4 front bumpers into the drawer front.

# Sensomatic for Dynapro

## Single drawer with top mounting

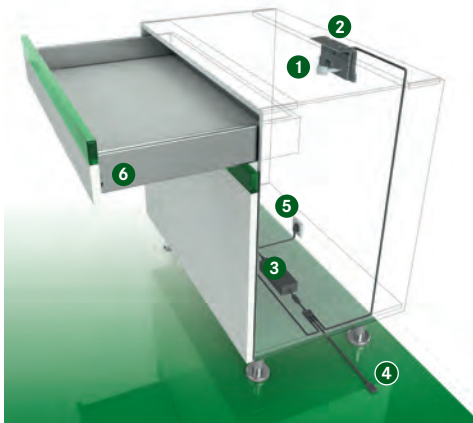

- Electro-mechanical opening system
- Sensomatic works with any Dynapro drawer design
- Activated by a light touch anywhere on the drawer front
- One drive unit for cabinets widths up to 47 1/4" (1200mm)
- Full-extension for maximum access to drawer contents
- Soft-closing action pulls the drawer closed
- Ideal for accessories such as wire baskets, waste bins, or roll-out trays

### 1 Opening Unit



	Item No.	PU
For Dynapro	<b>F121100268607</b>	10

PU - 10 pieces, individually packaged

### 2 Frame for Top Assembly



	Item No.	PU
Height 120mm (4 23/32")	<b>F121100272207</b>	10

**Note: product lead time approximately 12 weeks.**

### 3 Power Supply Unit



	Item No.	PU
Power supply unit	<b>F121100269607</b>	10

PU = 10 pieces, individually packaged. One power supply operates up to 30 opening units

### 4 Connection Cable with 2-way-adapter



Length	Item No.	PU
600mm	<b>F121100288207</b>	10
1000mm	<b>F121100289207</b>	10
1600mm	<b>F121100290207</b>	10
2000mm	<b>F121100291207</b>	10

### 5 Power Cord, 1.8 m (6')



Type of plug	Item No.	PU
Power cord (USA, CA)	<b>F120069760207</b>	10

### 6 Spring-loaded Front Bumper



Ø 5mm	Item No.	PU
Front gap 2.2mm	<b>F121100294223</b>	100
Front gap 3mm	<b>F121100295223</b>	100

PU - Packaging unit

## Mounting Dimensions

Back wall cabling

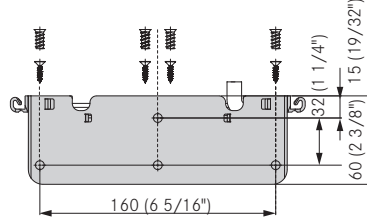
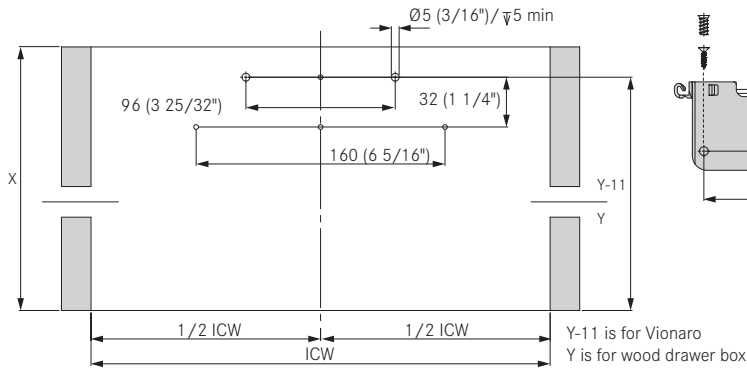
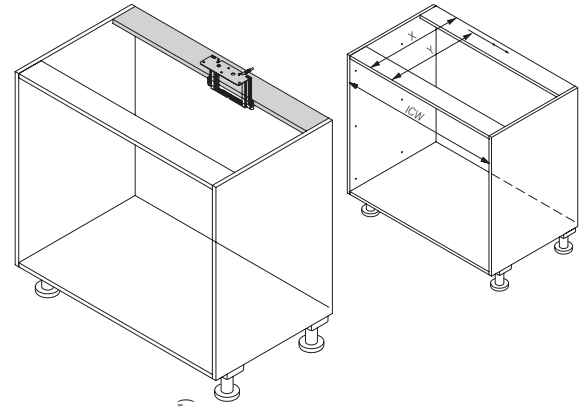
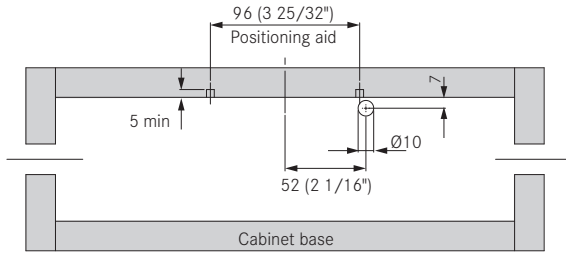

Mounting dimensions Dynapro	X (inside)	Y	Min ICW
Wood back panel	NL + 15 (19/32")	NL	312 (12 9/32")

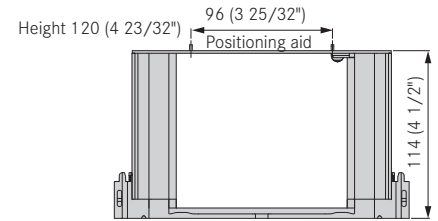

## Legend

### Position of Opening Unit for Dynapro

### Position of Front Bumper

Height 120 (4 23/32")

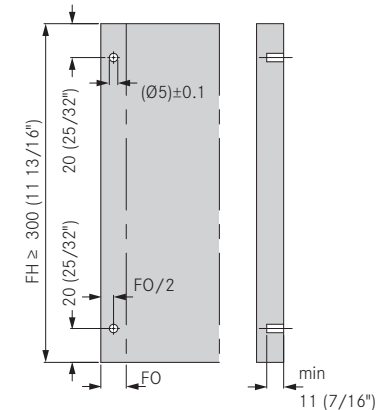
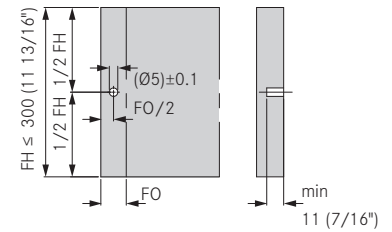
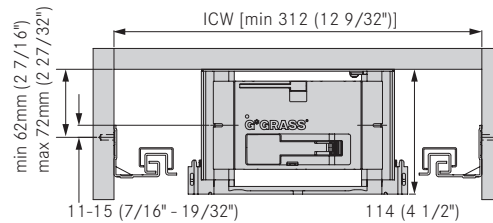

ICW = inside cabinet width  
 NL = nominal length of cabinet slide  
 X = min installation depth  
 Y = depth of hole pattern

FH = front height  
 FO = front overlay

When mounting the heavy-duty slide (132 lbs.), it is necessary to insert 4 front bumpers into the drawer front.



# Sensomatic for Dynapro

## Waste bin cabinet with bottom panel frame mounting

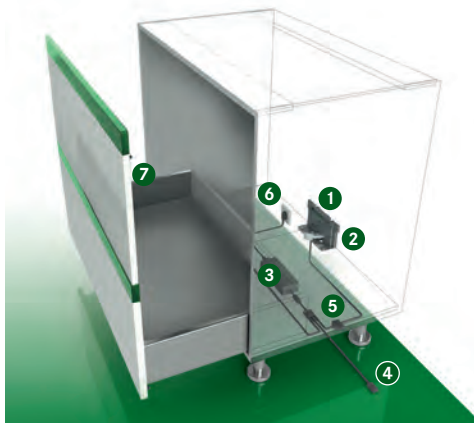

- Electro-mechanical opening system
- Sensomatic works with any Dynapro drawer design
- Activated by a light touch anywhere on the drawer front
- One drive unit for cabinets widths up to 47 1/4" (1200mm)
- Full-extension for maximum access to drawer contents
- Soft-closing action pulls the drawer closed
- Ideal for accessories such as wire baskets, waste bins, or roll-out trays

### 1 Opening Unit



	Item No.	PU
For Dynapro	<b>F121100268607</b>	10
PU - 10 pieces, individually packaged		

### 2 Base Frame



	Item No.	PU
for Dynapro	<b>F121100271207</b>	10

### 3 Power Supply Unit



	Item No.	PU
Power supply unit	<b>F121100269607</b>	10
PU = 10 pieces, individually packaged One power supply operates up to 30 opening units		

### 4 Connection Cable with 2-way-adapter



Length	Item No.	PU
1000mm	<b>F121100289207</b>	10
1600mm	<b>F121100290207</b>	10
2000mm	<b>F121100291207</b>	10

### 5 4-way-adapter



Type of plug	Item No.	PU
4-way-adapter	<b>F121100293207</b>	10

### 6 Power Cord, 1.8 m (6')



Type of plug	Item No.	PU
Power cord (USA, CA)	<b>F120069760207</b>	10

### 7 Spring-loaded Front Bumper



Ø 5mm	Item No.	PU
Front gap 2.2mm	<b>F121100294223</b>	100
Front gap 3mm	<b>F121100295223</b>	100

## Sensomatic Kit



### Set includes:

Opening unit: 1      Power cord: 1  
 Base frame: 1      Front bumpers: 4  
 Power supply unit : 1      (F121100294223)

	Item No.	PU
For Dynapro	<b>F121100697201</b>	1

PU = 1 set

PU - Packaging unit

## Mounting Dimensions

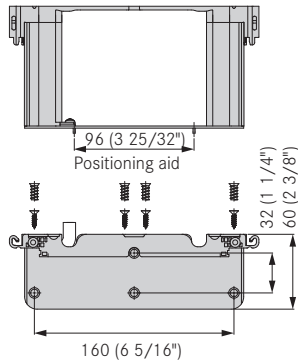

Base mounting

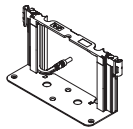
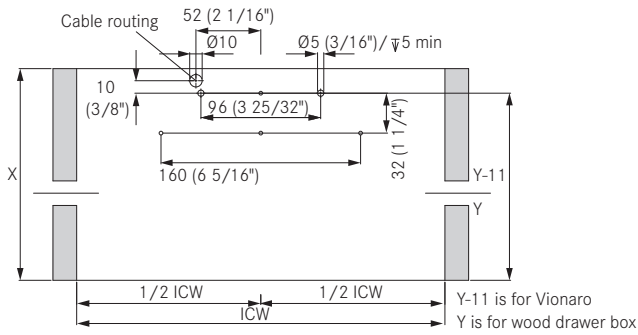
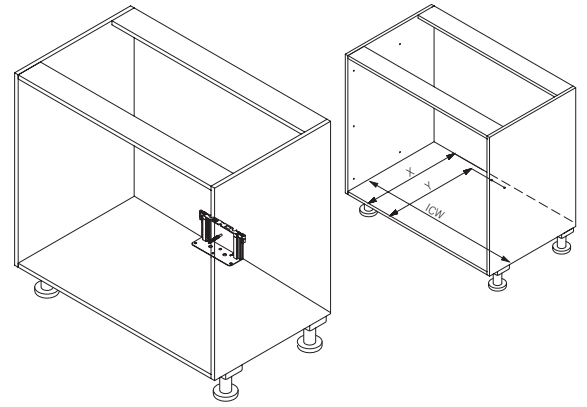

Base frame

Mounting dimensions Dynapro	X (inside)	Y	Min ICW
Wood back panel	NL + 15 (19/32")	NL	312 (12 9/32")

## Legend

### Position of Opening Unit for Dynapro

### Position of Front Bumper

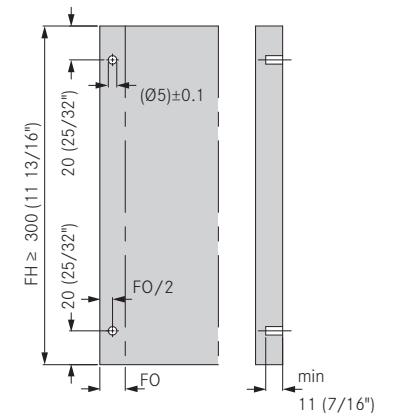
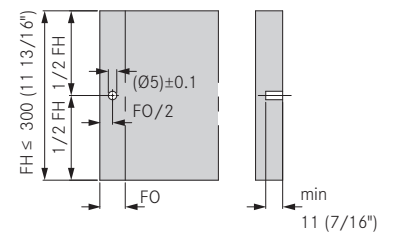
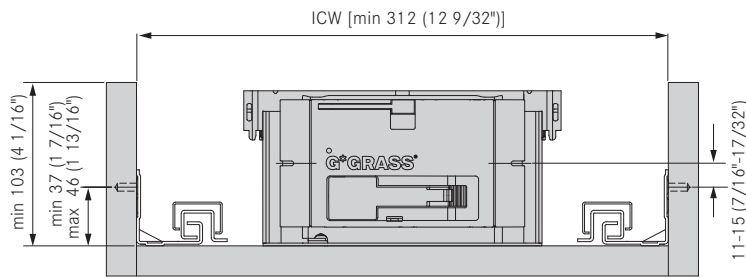

ICW = inside cabinet width  
 NL = nominal length of cabinet slide  
 X = min installation depth  
 Y = depth of hole pattern

FH = front height  
 FO = front overlay

When mounting the heavy-duty slide (132 lbs.), it is necessary to insert 4 front bumpers into the drawer front.



GRASS America Inc.  
1202 NC Highway 66 South  
Kernersville, NC 27284

Phone: 1-800-334-3512  
Fax: 1-800-525-8406

[www.grassusa.com](http://www.grassusa.com)  
[info@grassusa.com](mailto:info@grassusa.com)

GRASS Canada Inc.  
3135 Markham Road  
Toronto, ON M1X 0B5

Phone: 1-800-461-4975  
Fax: 1-416-335-5907

[www.grasscanada.com](http://www.grasscanada.com)  
[info@grasscanada.com](mailto:info@grasscanada.com)

