



ELITE PLUS



G*GRASS®

ELITE PLUS SLIDE SYSTEM

Undermount drawer technology with a precision roller carriage and smooth closing action





Bringing together the advances of undermount technology with a precision roller carriage.

With an even better Soft-close action



Elite Plus pulls open easily and the unique closing action with the Airmatic is smooth and silent.

The innovative Elite Plus drawer slide draws attention to the beauty of your cabinetry and leaves the mounted hardware completely out of sight.

The Elite Plus brings together the advances of undermount technology with a precision roller carriage and features the Airmatic closing device. The Airmatic uses natural, clean air to deliver a soft, quiet closing action every time. Offered in a full range of lengths for frameless and face frame construction, the Elite Plus features a full drawer extension for maximum use of interior space. It is a proven undermount slide with an ample load capacity of 75 lbs. that meets and exceeds ANSI/BHMA Grade 1 testing standards. Year after year, Elite Plus enables drawers to function quietly and flawlessly with the quality construction and Grass standard of excellence you have come to expect.



Table of Content

	Description	Adjustment	Page
	Features and Benefits		4-5
	Elite Plus 16 <ul style="list-style-type: none"> • Integrated Airmatic Soft-close • Full extension • For 5/8" (16mm) material 	<ul style="list-style-type: none"> • Height adjustment (2.5 mm) • Side tolerance, left side (max. \pm 1.5 mm) 	6
	Elite Plus 19 <ul style="list-style-type: none"> • Integrated Airmatic Soft-close • Full extension • For 3/4" (19mm) material 	<ul style="list-style-type: none"> • Height adjustment (2.5 mm) • Side tolerance, left side (max. \pm 1.5 mm) 	8
	V-notch Brackets <ul style="list-style-type: none"> • V-notch Brackets, 19mm 		10
	Accessories <ul style="list-style-type: none"> • Drilling Template • Screws 		11

Weight Capacities per pair of slides

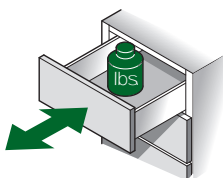

Elite Plus: 75 lbs dynamic load rating; 100 lbs static load rating

Elite Plus meets and exceeds the minimum requirements of ANSI/BHMA 156.1 standard, Grade 1.

Elite Plus

Features and Benefits

Features



- Slides mount underneath to give full view of finely crafted drawers
- Airmatic shock absorber softly glides drawers to a stop
- Weight capacity: 75 lbs dynamic, 100 lbs static.
- Available for 5/8" and 3/4" drawer side thickness
- For frameless and face frame construction

Standard locking device

with height adjustment

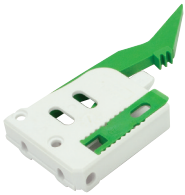

The standard front locking device allows aligning the height of the drawer. A 2.5mm [3/32"] upwards adjustment is achieved via the green adjustment plate by moving it forward and back.

Flange mount locking device

with height adjustment



This special front locking device features a flange for easy mounting to the bottom of the drawer. The height of the drawer can be adjusted by 2.5mm [3/32"] via the green adjustment plate.

Self-aligning rear mount brackets



Brackets self-align the drawer when cabinets are out of square, $\pm 2\text{mm}$ [3/32"] adjustment range.

- **Frame stop tab**

Quickly locates the slide on the face frame at the correct setback.

- **Multiple cleats**

For secure front locking.



- **Minimal opening force**

Superb soft-closing action.

Features

- The repositioned Airmatic damper provides:
 - Narrower drawer widths (9" inside width)
 - Easier insertion and removal of drawer
 - More compact and appealing design
 - No protruding parts inside cabinet
 - Basic proven slide concept has not changed

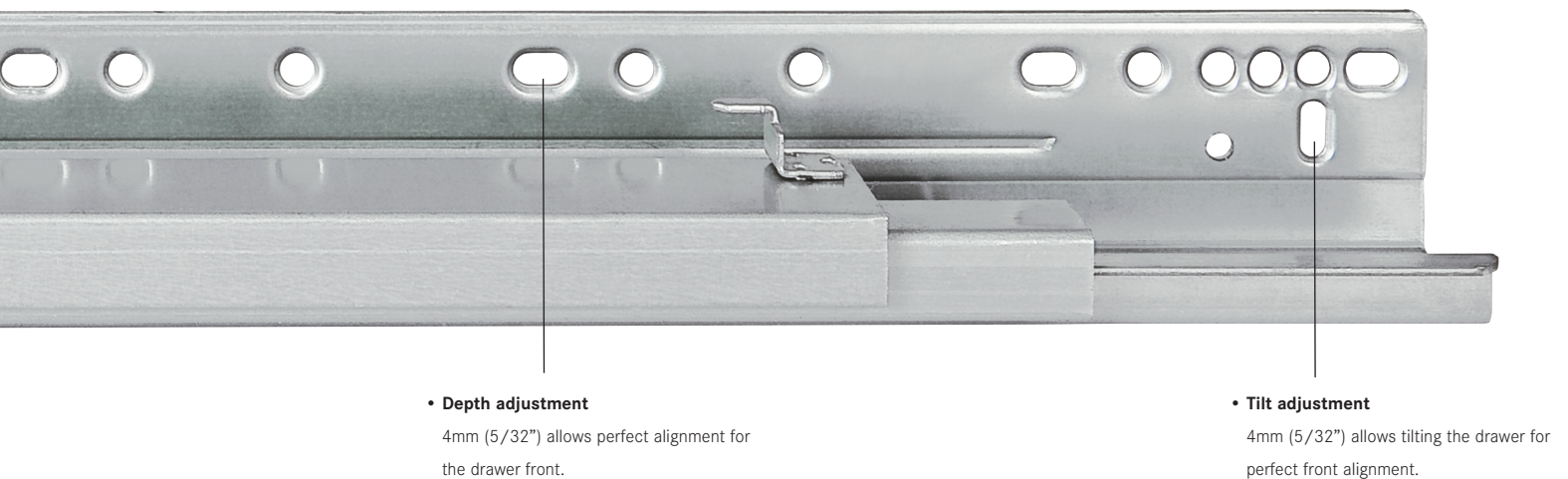
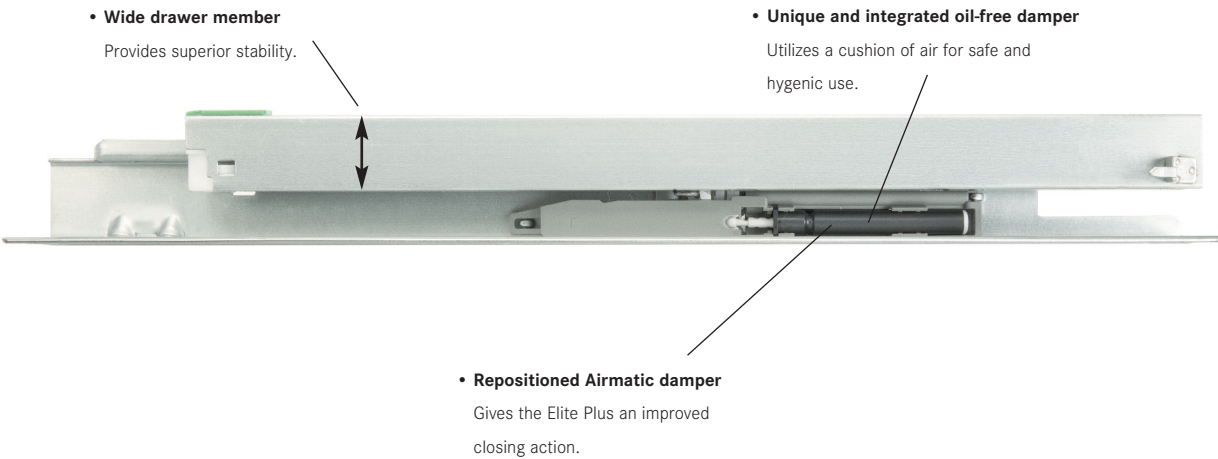

Elite Plus 16

Full Extension Slide for 16mm (5/8") maximum drawer thickness

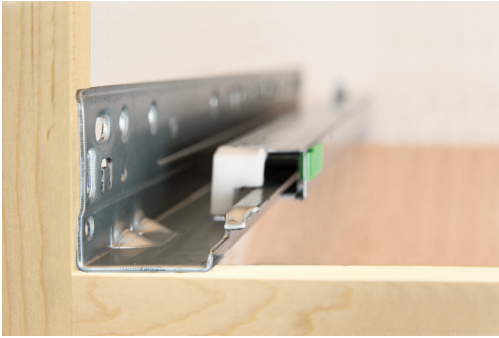

- Slides mount underneath to give a full view of finely crafted drawers
- Zinc plated, roll formed steel components
- Precision, smooth-running synthetic roller carriages
- Airmatic damper softly glides drawers to a stop
- Self-latching front locking devices have comfortable release levers for drawer removal
- Front locking device height adjustable 2.5mm [3/32"]
- Positive tracked right side, ± 1.5mm [1/16"] side tolerance on left side
- Self-closing springs engage 30mm [1 1/4"] before closed position
- Weight capacity: 75 lbs. dynamic, 100 lbs. static
- Exceeds ANSI/BHMA 156.9, Grade 1, Type B05011 drawer slide, test standards

Elite Plus 16



Drawer length	Nominal length	Min Installation Depth	Max Installation Depth	Item No.	PU
240 (9 5/8")	250 (9 27/32")	259 (10 3/16")	296 (11 5/16")	13031-03	5
305 (12")	317 (12 15/32")	329 (12 15/16")	363 (14 3/16")	13033-03	5
381 (15")	394 (15 1/2")	407 (16")	440 (17 3/16")	13035-03	5
457 (18")	470 (18 1/2")	479 (18 7/16")	516 (20 3/16")	13039-03	5
533 (21")	550 (21 21/32")	562 (22 1/8")	596 (23 7/16")	13043-03	5
381 (15")	394 (15 1/2")	407 (16")	440 (17 3/16")	13035-12	200
457 (18")	470 (18 1/2")	479 (18 7/16")	516 (20 3/16")	13039-12	200
533 (21")	550 (21 21/32")	562 (22 1/8")	596 (23 7/16")	13043-12	200

*For frameless applications, deduct 1.5mm [1/16"] for minimum installation depth.

Locking devices and Rear mount bracket



Description	Item No.	PU
(Please order separately)		
1a 7523 Front locking device kit*	02614-12	200
Locking device Left	02615-12	200
Locking device Right	02616-12	200
1b 7523 Front locking device kit* with flange	02613-03	5
Locking device Left with flange	02611-12	200
Locking device Right with flange	02612-12	200
2 7523 Universal rear mount bracket**	7950.VE20	20
7523 Universal rear mount bracket**	7950.VE300	300

*Kit: Left/ Right locking device, (4) #6 x 1/2" flat head phillips screws, **Plug-in brackets available on page 12.

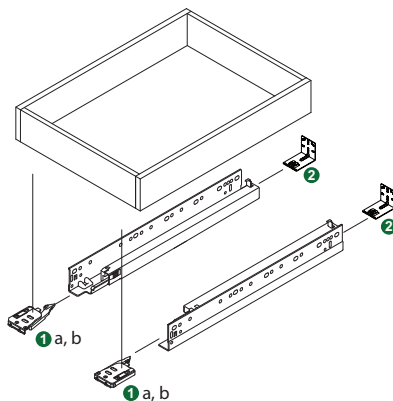

PU = Packaging Unit

Drawer installation dimensions

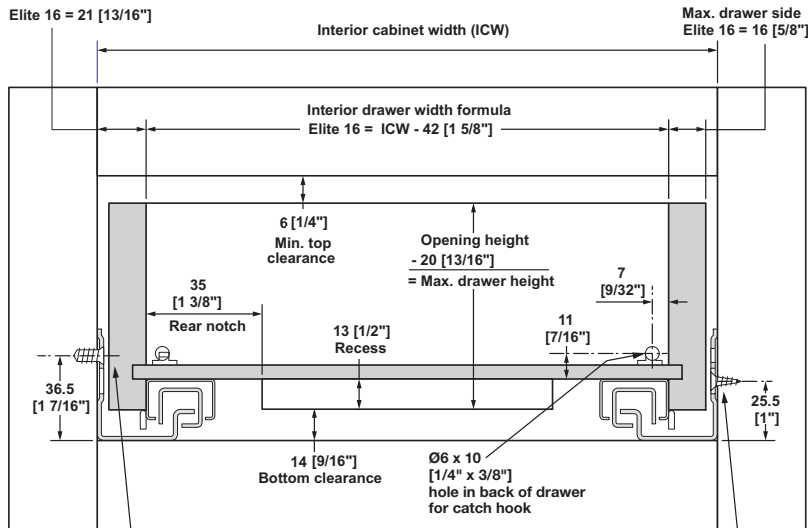

Euro screw Ø5 x 13mm or #7 x 5/8" flat head wood screw location on panel cabinets

#7 wood screw location at face frame

Rear Bracket Position

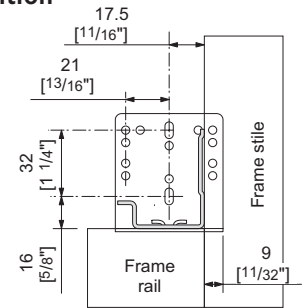

For face frame applications only. Use minimum of 3 screws per bracket, #6 x 1/2" truss head screws.

Drawer Measurements

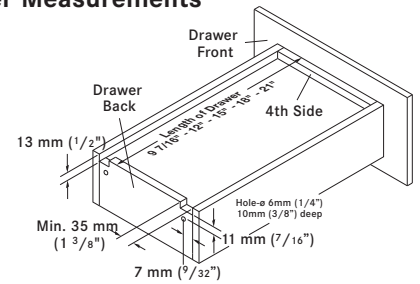

Frameless cabinet member boring specifications

Face Frame cabinet member boring specifications

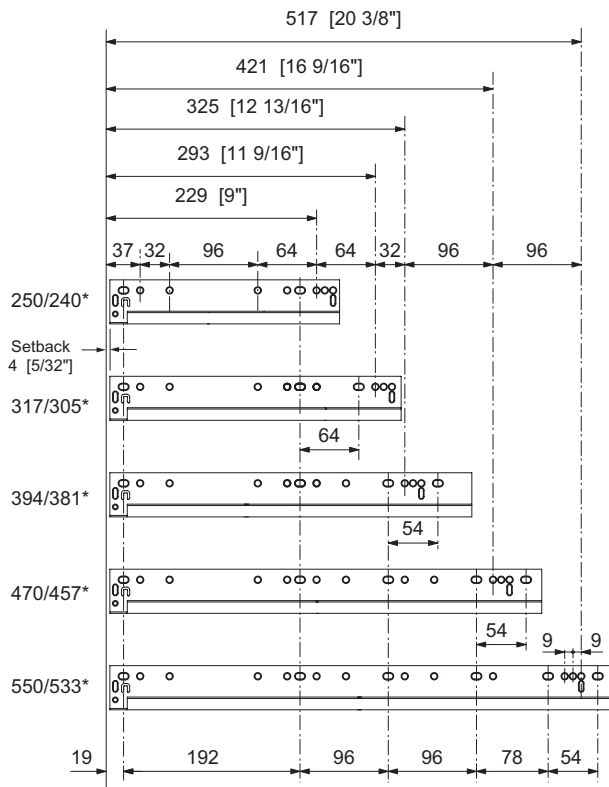

Slotted hole locations for inset applications

*Cabinet member length / Drawer length (mm)

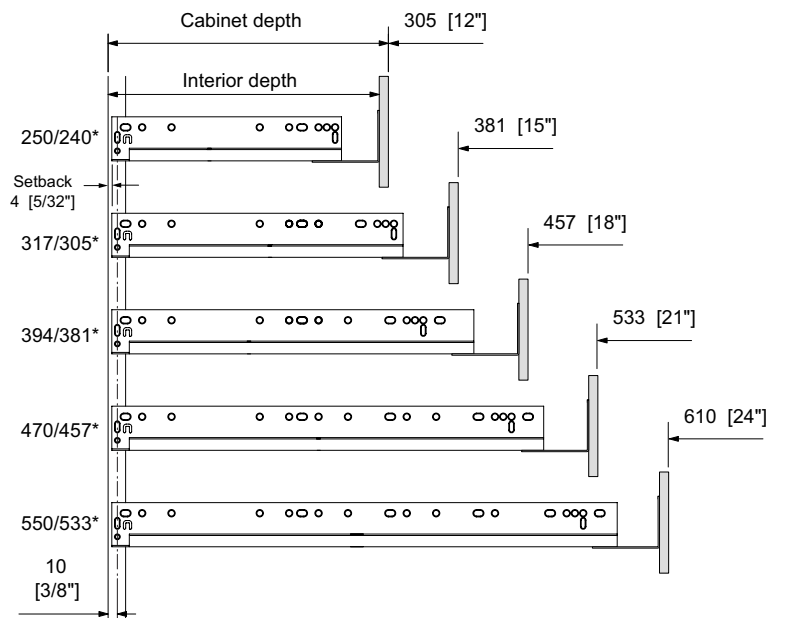

All dimensions in millimeters.

Elite Plus 19

Full Extension Slide for 19mm (3/4") maximum drawer thickness



- Slides mount underneath to give a full view of finely crafted drawers
- Zinc plated, roll formed steel components
- Precision, smooth-running synthetic roller carriages
- Airmatic damper softly glides drawers to a stop
- Self-latching front locking devices have comfortable release levers for drawer removal
- Front locking device height adjustable 2.5mm [1/32"]
- Positive tracked right side, ± 1.5mm [1/16"] side tolerance on left side
- Self-closing springs engage 30mm [1 1/4"] before closed position
- Weight capacity: 75 lbs. dynamic, 100 lbs. static
- Exceeds ANSI/BHMA 156.9, Grade 1, Type B05011 drawer slide, test standards

Elite Plus 19



Drawer length	Nominal length	Min Installation Depth	Max Installation Depth	Item No.	PU
240 (9 5/8")	250 (9 27/32")	259 (10 3/16")	296 (11 5/16")	13032-03	5
305 (12")	317 (12 15/32")	329 (12 15/16")	363 (14 3/16")	13034-03	5
381 (15")	394 (15 1/2")	407 (16")	440 (17 3/8")	13037-03	5
457 (18")	470 (18 1/2")	479 (18 7/8")	516 (20 3/8")	13041-03	5
533 (21")	550 (21 2/32")	562 (22 1/8")	596 (23 7/16")	13046-03	5
457 (18")	470 (18 1/2")	479 (18 7/8")	516 (20 3/8")	13041-12	200
533 (21")	550 (21 2/32")	562 (22 1/8")	596 (23 7/16")	13046-12	200

*For frameless applications, deduct 1.5mm [1/16"] for minimum installation depth.

Locking devices and Rear mounting bracket



Description	Item No.	PU
(Please order separately)		
1a 7523 Front locking device kit*	02614-12	200
Locking device Left	02615-12	200
Locking device Right	02616-12	200
1b 7523 Front locking device kit* with flange	02613-03	5
Locking device Left with flange	02611-12	200
Locking device Right with flange	02612-12	200
2 7523 Universal rear mount bracket**	7950.VE20	20
7523 Universal rear mount bracket**	7950.VE300	300

*Kit: Left/ Right locking device, (4) #6 x 1/2" flat head phillips screws, **Plug-in brackets available on page 12.

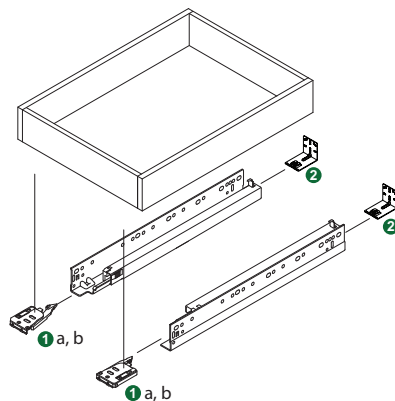

PU = Packaging Unit

Drawer installation dimensions

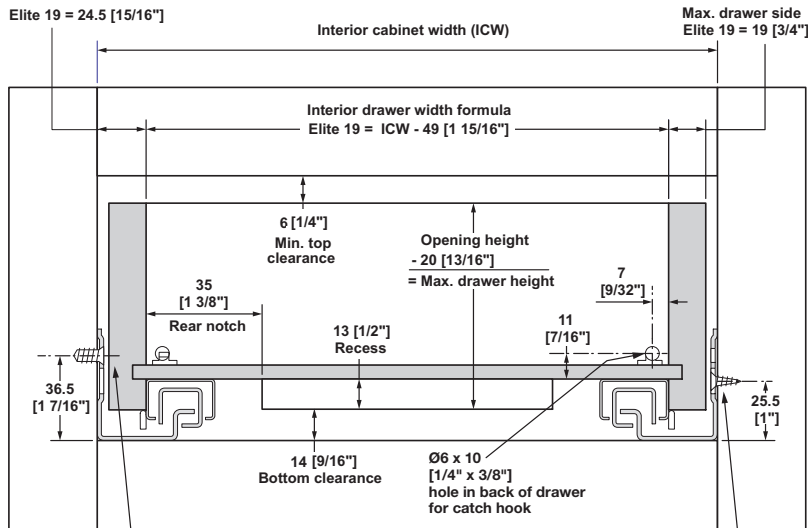

Euro screw Ø5 x 13mm or #7 x 5/8" flat head wood screw location on panel cabinets

#7 wood screw location at face frame

Rear Bracket Position

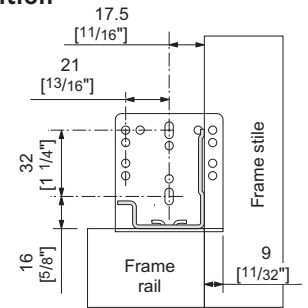

For face frame applications only. Use minimum of 3 screws per bracket, #6 x 1/2" truss head screws.

Drawer Measurements

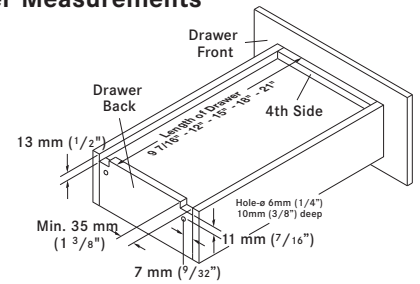

Frameless cabinet member boring specifications

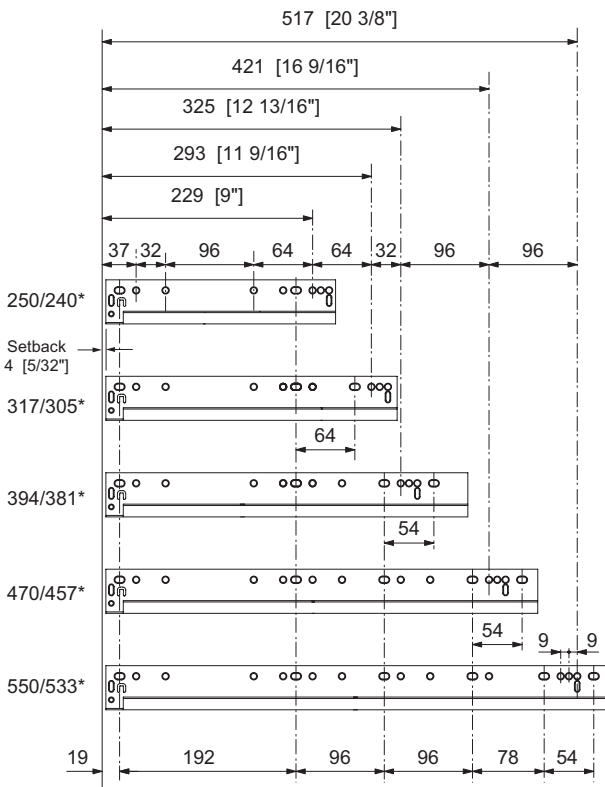

Slotted hole locations for inset applications

*Cabinet member length / Drawer length (mm)

Face Frame cabinet member boring specifications

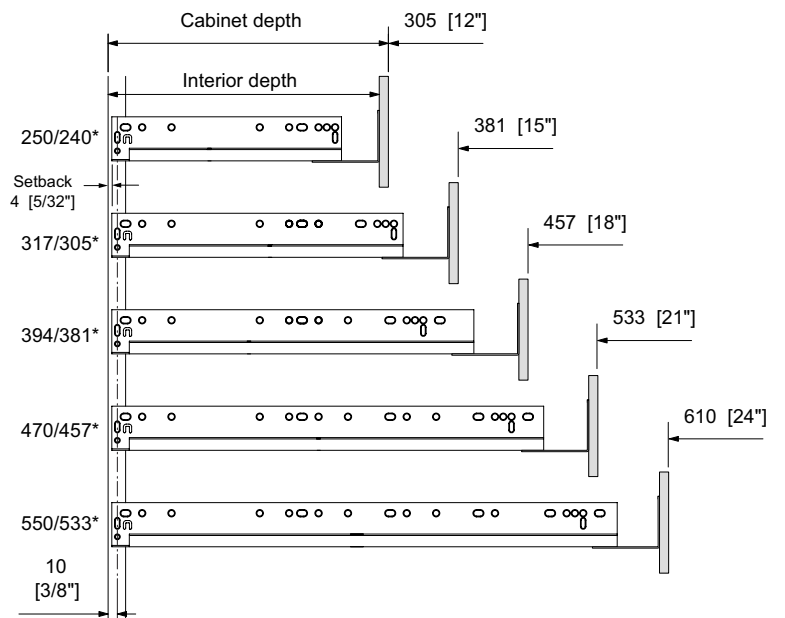

All dimensions in millimeters.

Elite Plus

Accessories and assembly aides

V-notch rear mounting brackets, 19mm

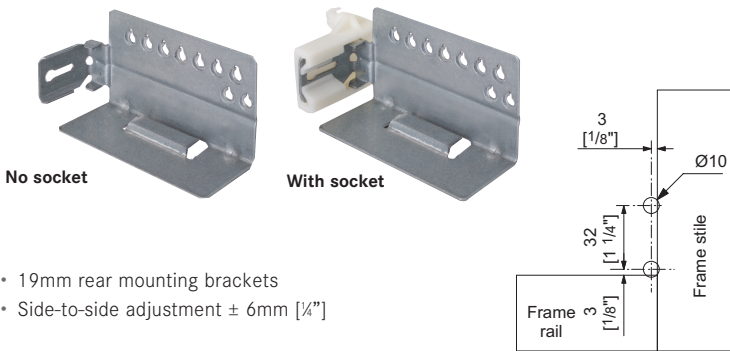

- 19mm rear mounting brackets
- Side-to-side adjustment $\pm 6\text{mm}$ [$1/4$ "]

Description	Item No.	PU
V-notch, metal, no socket, left	02212-12	200
V-notch, metal, no socket, right	02213-12	200
V-notch, metal, with socket, left	02216-12	200
V-notch, metal, with socket, right	02217-12	200

Drilling Template

- Use to precisely bore holes in the drawer back
- Use with a standard $1/4$ " drill bit and stop collar

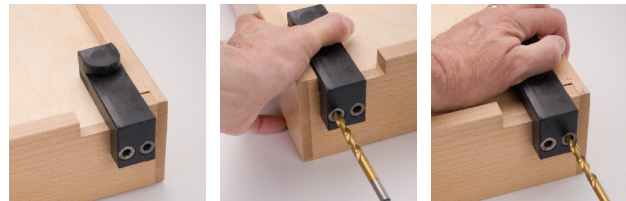

Left side drilling

Right side drilling

Description	Item No.	PU
Elite Plus drilling template	02511-01	1

Wood screw, nickel plated

Steel, nickel plated
(Phillips)

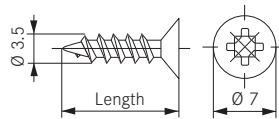

Type	Item No.	PU
Flathead $\varnothing 6 \times 5/8$ "	81001-43	500
Flathead $\varnothing 6 \times 3/4$ "	81003-43	500

Euro screw, nickel plated

Steel, nickel plated
(Pozi)

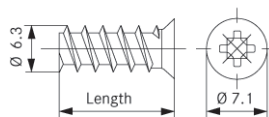

Type	Item No.	PU
Euro Screw $\varnothing 6.3 \times 11\text{mm}$ (7/16")	499.360.61.1015	500
Euro Screw $\varnothing 6.3 \times 13\text{mm}$ (1/2")	499.360.61.3015	500

PU = Packaging Unit



GRASS America Inc.
1202 NC Highway 66 South
Kernersville, NC 27284

Phone: 1-800-334-3512
Fax: 1-800-525-8406

Website: www.grassusa.com
E-mail: info@grassusa.com

GRASS Canada Inc.
10 Newgale Gate, Unit 7
Toronto, ON M1X 1C5

Phone 1-800-461-4975
Fax 1-416-335-5907

Internet: www.grasscanada.com
E-Mail: info@grasscanada.com



www.grassusa.com