

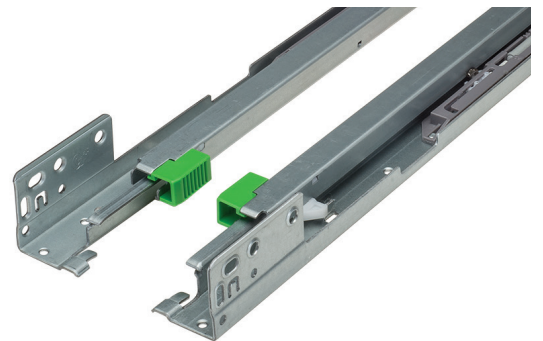

G*GRASS®

MAXCESS SLIDE SYSTEM

Full access, soft-close slide. An economical undermount that offers a high degree of convenience and satisfaction with minimal extension loss.





Maxcess is the economical alternative to achieve full access into your drawer interior.

Maximize your drawer space

If you can imagine a full access slide with features such as higher quality and better value, then you have the power to see Maxcess, Grass' full access concealed undermount slide. Maxcess is an economical, soft-close, undermount slide that offers a high degree of convenience and satisfaction.

Designed for face frame and frameless cabinetry, the Maxcess easily fits conventional drawer construction with material thickness ranging from 12.7mm (1/2") to 19mm (3/4").

A new liquid damper, created with German technology, is integrated into the slide and provides a continuous smooth, easy close. The front locking devices offer 1D height adjustment or 2D height and side adjustment. Multiple cleats securely connect the drawer to the slide. Maxcess features an ample load capacity of 75 pounds that meets and exceeds ANSI/BHMA A156.9, Grade 1 testing standard and features a minimal extension loss. A new option in undermount slides built with the Grass standard of excellence you have come to expect.



Table of Content

	Description	Adjustment	Page
	Features & Benefits		4
	Technical Information		6
	<p>Maxcess 16</p> <ul style="list-style-type: none"> • Face frame application • Integrated Soft-close • 7/8 extension • For 16mm (5/8") material 	<p>Front locking device selection provides:</p> <ul style="list-style-type: none"> • Height adjustment (max +2.5mm) • Side adjustment (max ± 1.5mm) 	10
	<p>Maxcess 16</p> <ul style="list-style-type: none"> • Frameless application • Integrated Soft-close • 7/8 extension • For 16mm (5/8") material 	<p>Front locking device selection provides:</p> <ul style="list-style-type: none"> • Height adjustment (max +2.5mm) • Side adjustment (max ± 1.5mm) 	12
	<p>Maxcess 19</p> <ul style="list-style-type: none"> • Face frame application • Integrated Soft-close • 7/8 extension • For 19mm (3/4") material 	<p>Front locking device selection provides:</p> <ul style="list-style-type: none"> • Height adjustment (max +2.5mm) • Side adjustment (max ± 1.5mm) 	14
	<p>Accessories and Assembly Aids</p> <ul style="list-style-type: none"> • Drilling template • Screws • Bumpers 		16

Features and Benefits

Maxcess

Features



- Slide is concealed to give full view of finely crafted drawers
- Self-latching front locking devices have easy release levers for drawer removal
- 7/8 extension with minimal extension loss on a 21" drawer
- Liquid damper softly glides drawers to a stop
- For drawer material thickness: 12.7mm (1/2") to 19mm (3/4")
- For face frame and frameless construction
- Patented load bearing support roller minimizes deflection
- Positive stop
- Height adjustment +2.5mm (3/32") with suitable front locking device
- Side adjustment $\pm 1.5\text{mm}$ (1/16") with suitable front locking device
- Weight capacity: 75 lb dynamic, 100 lb static
- Meet and exceeds ANSI/BHMA A156.9 Standard, Grade 1

Depth adjustment

4mm (5/32") allows perfect alignment for the drawer front.

Multiple cleats

for secure front locking.

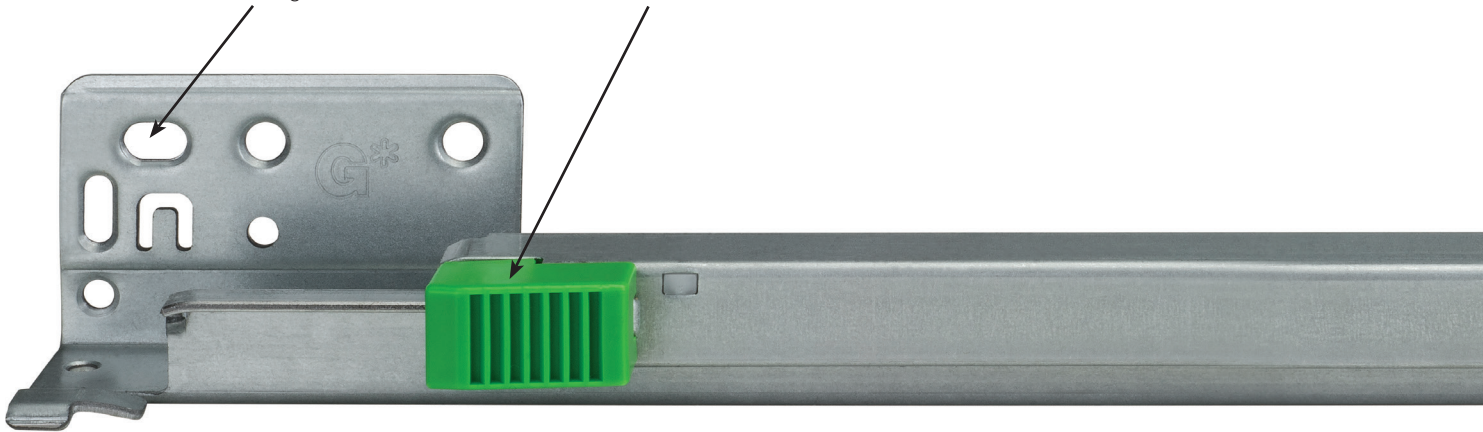

1D Front locking device

with height adjustment +2.5mm (3/32")

The front locking device securely connects the drawer to the slide.



2D Front locking device

with height adjustment +2.5mm (3/32")
with side adjustment $\pm 1.5\text{mm}$ (1/16")

The front locking device securely connects the drawer to the slide.

Features

- Precision smooth running roller carriage
- German technology liquid damper with smooth closing action
- Uses same front locking devices as Elite Plus
- Rear notch in back of box is 35mm for Maxcess and Elite Plus
- Patented design

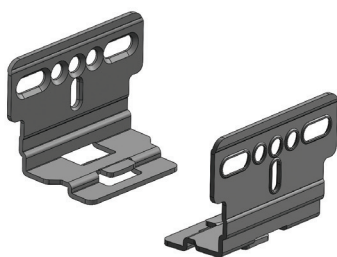
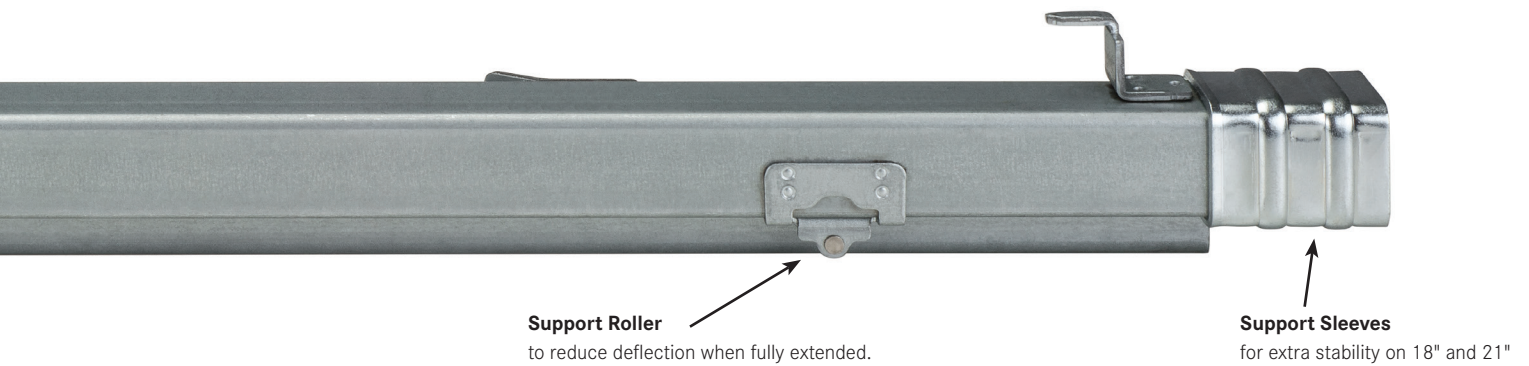
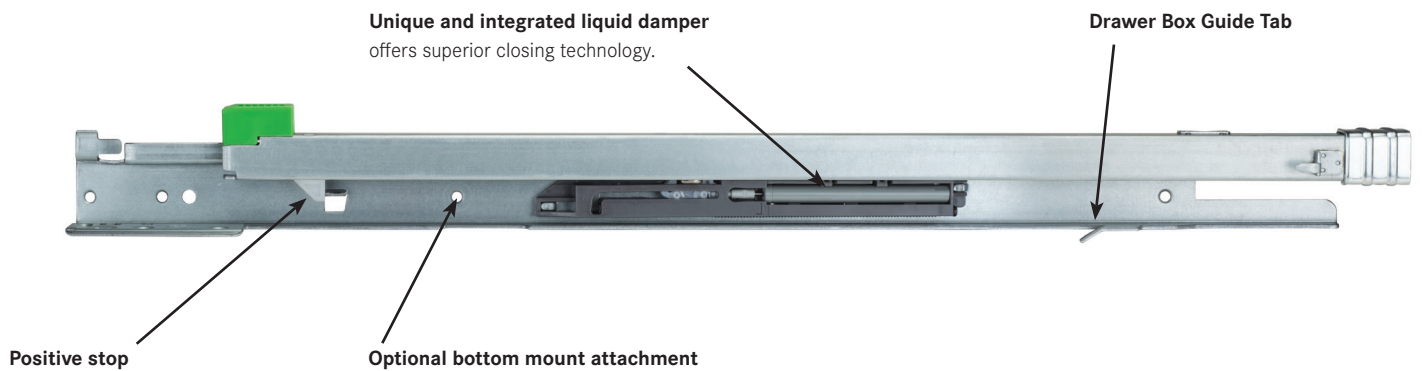

Technical Information

Maxcess

Front Locking Device with Height Adjustment

7523 Front Locking Device, 1D

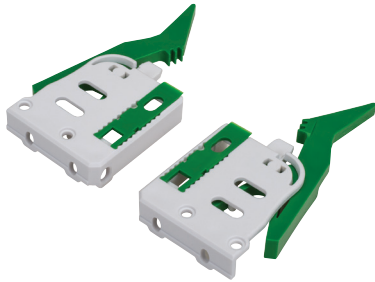

- Securely connects the drawer to the slide
- Height adjustment range: +2.5mm (3/32")
- For standard width drawers
- Minimum inside drawer width 125mm (4 15/16")
- Lightweight, high strength material

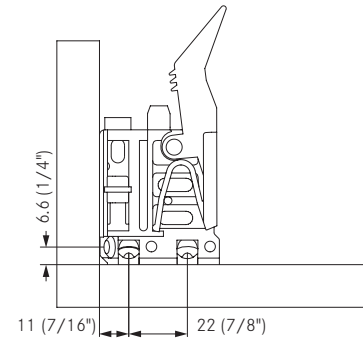

7523 Flanged Front Locking Device, 1D



- Securely connects the drawer to the slide
- Height adjustment range: +2.5mm (3/32")
- For standard width drawers
- Minimum inside drawer width 125mm (4 15/16")
- Lightweight, high strength material

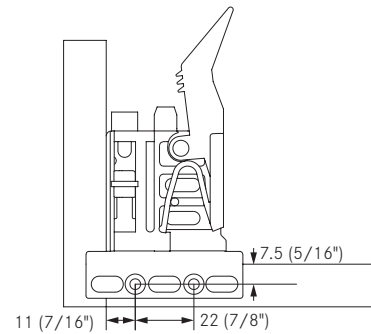

Front Locking Device with Height Adjustment and Side Adjustment

75X3 Front Locking Device, 2D

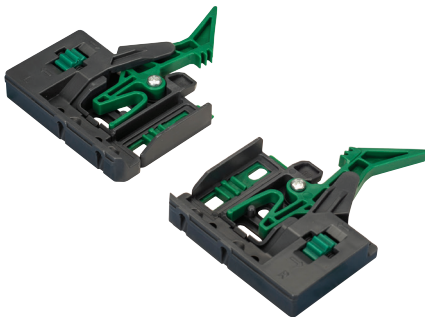

- Securely connects the drawer to the slide
- Height adjustment range: +2.5mm (3/32")
- Side adjustment range: ±1.5mm (1/16")
- For standard width drawers
- Minimum inside drawer width 150mm (5 7/8")
- Lightweight, high strength material

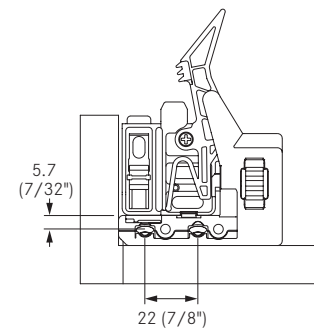

75X3 Flanged Front Locking Device, 2D

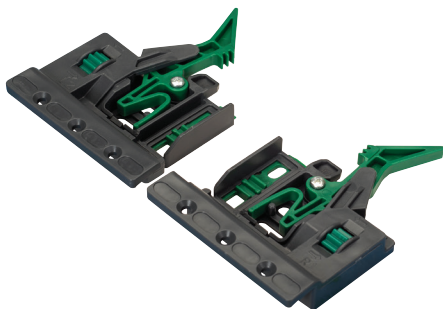

- Securely connects the drawer to the slide
- Height adjustment range: +2.5mm (3/32")
- Side adjustment range: ±1.5mm (1/16")
- For standard width drawers
- Minimum inside drawer width 150mm (5 7/8")
- Lightweight, high strength material

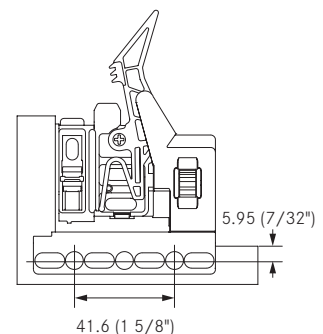

Rear Mounting Brackets

Universal - Rear Mounting Bracket



- For all Maxcess drawers
- For face frame application

Pre-drilling recommended $\varnothing 2.5\text{mm}$ (3/32")

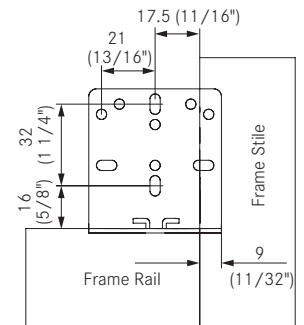

Euro - Rear Mounting Bracket

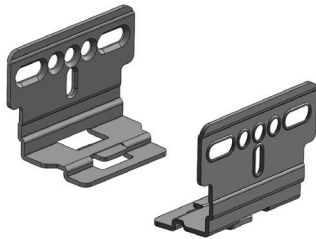

- For all Maxcess drawers
- For frameless application

Pre-drilling recommended $\varnothing 2.5\text{mm}$ (3/32")

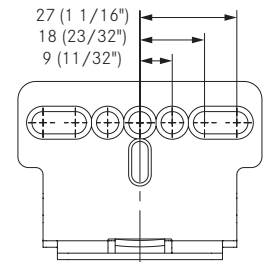

Technical Information

Maxcess

Maxcess Application

- For drawer material from 12.7mm (1/2") up to 19mm (3/4")
- For frameless or face frame application
- Rear brackets for frameless and face frame applications

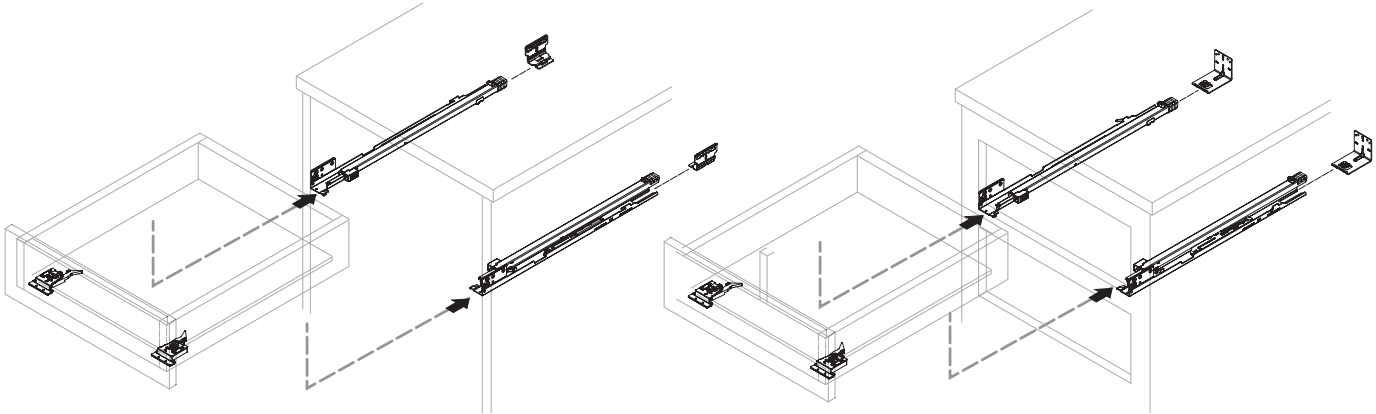

Inserting the Drawer

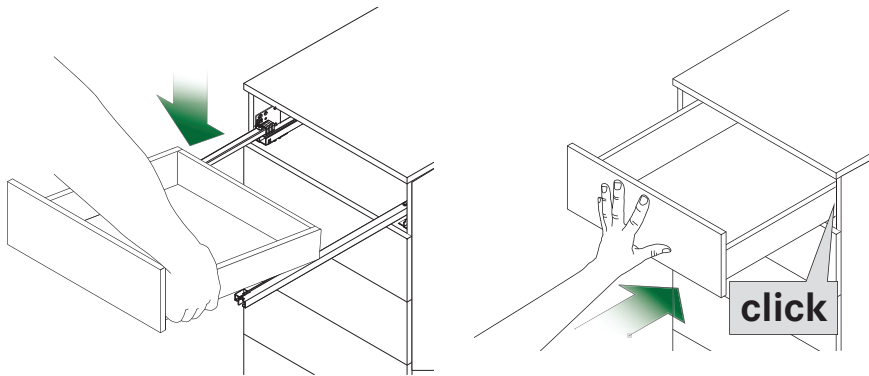

Place drawer on extended Maxcess slide and push in until it engages audibly

Disengaging the Drawer 7523, 1D

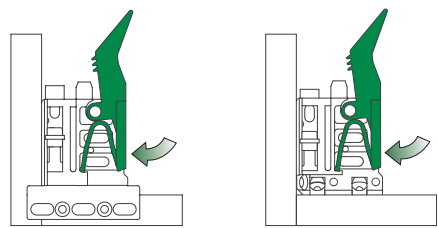

Flanged Front Locking Device Front Locking Device

Pull the drawer out, squeeze the locking device levers and lift drawer from the slide.

Disengaging the Drawer 75X3, 2D

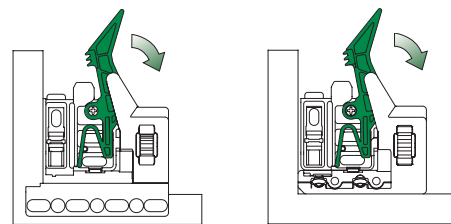

Flanged Front Locking Device Front Locking Device

Pull the drawer out, squeeze the locking device levers and lift drawer from the slide.

Maxcess

7523 Front Locking Device, 1D, Adjustment

Height Adjustment (max +2.5mm)

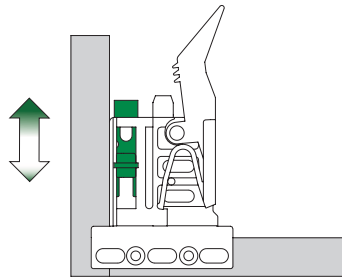
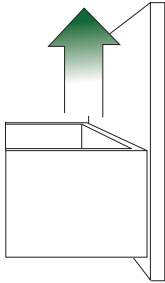

Flanged Front Locking Device

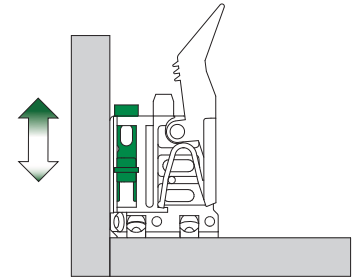

Front Locking Device

75X3 Front Locking Device, 2D, Adjustment

Height Adjustment (max +2.5mm)

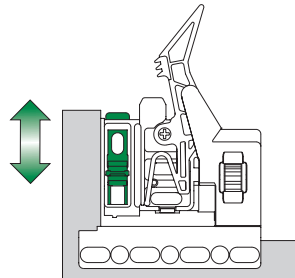
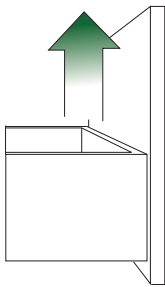

Flanged Front Locking Device

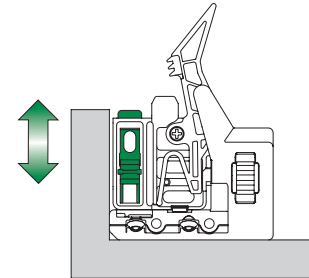

Front Locking Device

Side Adjustment (max ±1.5mm)

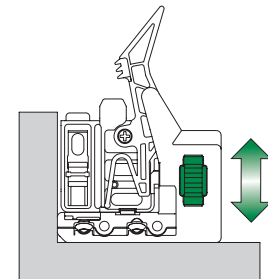
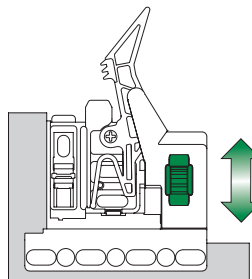
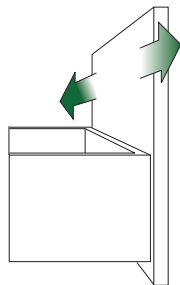

Weight Capacities per Pair of Slides

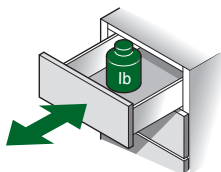

Maxcess: 75 lb dynamic load rating; 100 lb static load rating

Maxcess meets and exceeds the minimum requirements of ANSI/BHMA A156.9 Standard, Grade 1

Maxcess 16, Face Frame

Full Access for 16mm (5/8") drawer material



- Face frame applications from 12.7mm (1/2") up to 16mm (5/8") drawer material
- Zinc plated, roll formed steel components
- Precision, smooth-running synthetic roller carriages
- German technology liquid damper with smooth closing action
- Self-latching front locking devices have easy release levers for drawer removal and installation
- Height adjustment +2.5mm (3/32") with suitable front locking device
- Side adjustment ±1.5mm (1/16") with suitable front locking device
- Weight capacity: 75 lb dynamic; 100 lb static
- Meets and exceeds ANSI/BHMA A156.9 Standard, Grade 1

Maxcess 16, Face Frame



Drawer Length	Cab Mem Length	Min Installation Depth	Max Installation Depth	Item No.	PU
229 (9")	256 (10 3/32")	273 (10 3/4")	300 (11 13/16")	13301-03	5
305 (12")	316 (12 7/16")	349 (13 3/4")	360 (14 3/16")	13302-03	5
381 (15")	392 (15 7/16")	426 (16 25/32")	436 (17 5/32")	13303-03	5
457 (18")	468 (18 7/16")	502 (19 3/4")	512 (20 5/32")	13304-03	5
533 (21")	545 (21 15/32")	578 (22 3/4")	589 (23 3/16")	13305-03	5
381 (15")	392 (15 7/16")	426 (16 25/32")	436 (17 5/32")	13303-12	200
457 (18")	468 (18 7/16")	502 (19 3/4")	512 (20 5/32")	13304-12	200
533 (21")	545 (21 15/32")	578 (22 3/4")	589 (23 3/16")	13305-12	200

Front Locking Devices and Rear Mounting Bracket

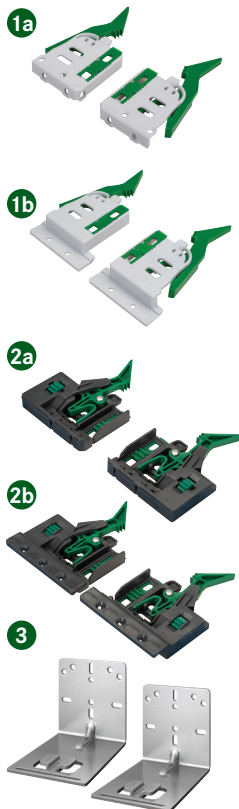

Description	Non-flanged Item No. (a)	Flanged Item No. (b)	PU
(Must order separately)			
1 7523 Front locking device, universal, 1D, kit*	02500-03	-	5
7523 Front locking device, universal, 1D, left	02498-12	02495-12	200
7523 Front locking device, universal, 1D, right	02499-12	02496-12	200
2 75X3 Front locking device, universal, 2D, left	80051-12	80053-12	200
75X3 Front locking device, universal, 2D, right	80052-12	80054-12	200
3 Universal rear mount bracket		7950.VE300	200

*Kit: Left/Right locking device, (4) #6 x 1/2" flat head Phillips screws

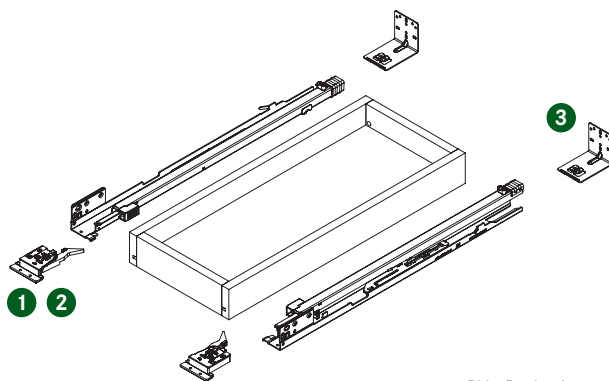

Patent Pending

PU - Packaging unit

Drawer Installation Dimensions

Drawer Measurements

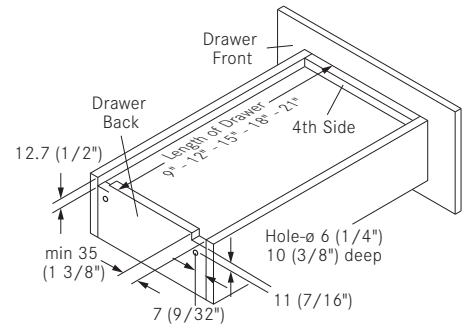
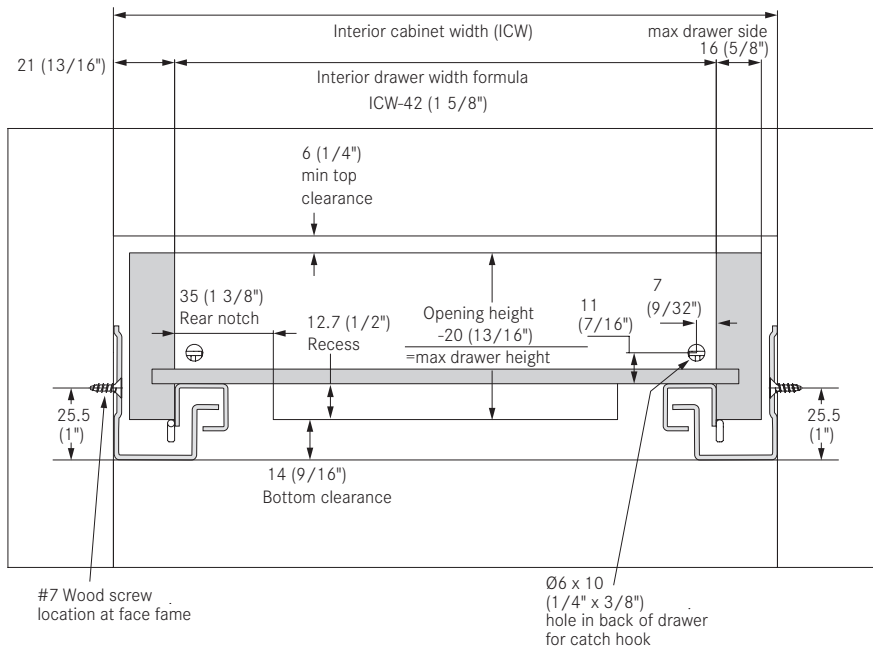

Rear Bracket Position

Cabinet Member Boring Specifications

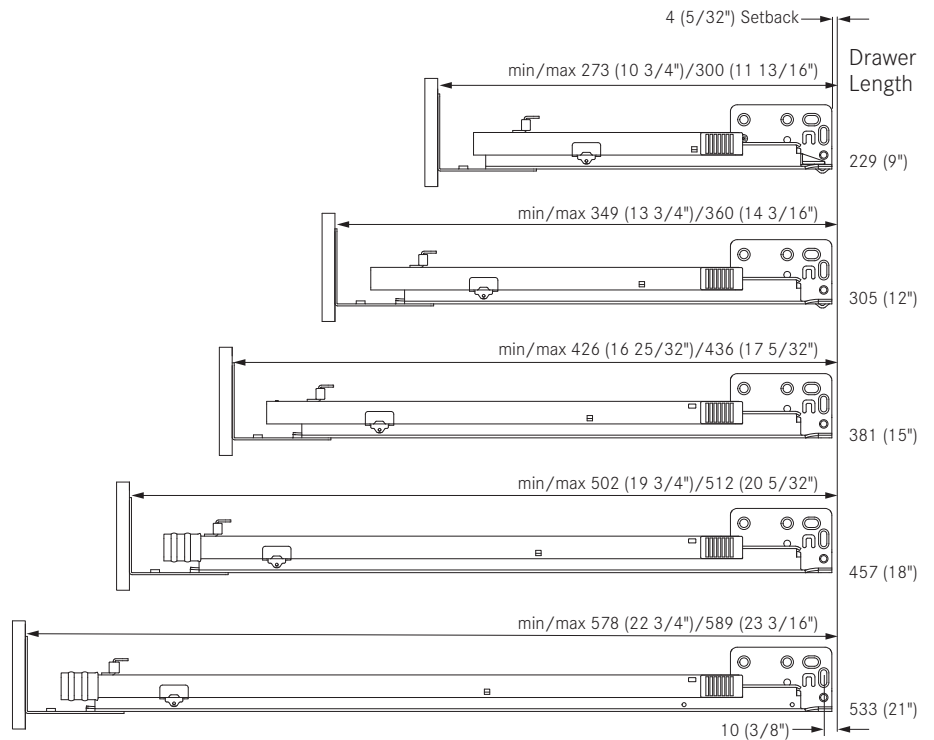
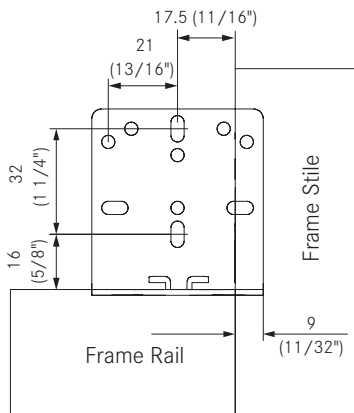

For face frame applications only. Use minimum of 3 screws per bracket, #6 x 1/2" truss head screws.

Pre-drilling recommended Ø2.5mm (3/32").

Note: The recommendations for screw placement are guidelines only. Installers need to ensure that the cabinet wall is adequate.

min/max = minimum/maximum installation depth

Maxcess 16, Frameless

Full Access for 16mm (5/8") drawer material



- Frameless applications from 12.7mm (1/2") up to 16mm (5/8") drawer material
- Zinc plated, roll formed steel components
- Precision, smooth-running synthetic roller carriages
- German technology liquid damper with smooth closing action
- Self-latching front locking devices have easy release levers for drawer removal and installation
- Height adjustment +2.5mm (3/32") with suitable front locking device
- Side adjustment ±1.5mm (1/16") with suitable front locking device
- Weight capacity: 75 lb dynamic; 100 lb static
- Meets and exceeds ANSI/BHMA A156.9 Standard, Grade 1

Maxcess 16, Frameless



Drawer Length	Cab Mem Length	Min Installation Depth	Item No.	PU
229 (9")	256 (10 3/32")	273 (10 3/4")	13331-03	5
305 (12")	316 (12 7/16")	349 (13 3/4")	13332-03	5
381 (15")	392 (15 7/16")	426 (16 25/32")	13333-03	5
457 (18")	468 (18 7/16")	502 (19 3/4")	13334-03	5
533 (21")	545 (21 15/32")	578 (22 3/4")	13335-03	5
381 (15")	392 (15 7/16")	426 (16 25/32")	13333-12	200
457 (18")	468 (18 7/16")	502 (19 3/4")	13334-12	200
533 (21")	545 (21 15/32")	578 (22 3/4")	13335-12	200

Front Locking Devices and Rear Mounting Bracket



Description	Non-flanged Item No. (a)	Flanged Item No. (b)	PU
(Must order separately)			
1 7523 Front locking device, universal, 1D, kit*	02500-03	-	5
7523 Front locking device, universal, 1D, left	02498-12	02495-12	200
7523 Front locking device, universal, 1D, right	02499-12	02496-12	200
2 75X3 Front locking device, universal, 2D, left	80051-12	80053-12	200
75X3 Front locking device, universal, 2D, right	80052-12	80054-12	200
3 Maxcess - Euro rear mounting bracket, non-handed		13380-03	10
Maxcess - Euro rear mounting bracket, non-handed		13380-12	200

*Kit: Left/Right locking device, (4) #6 x 1/2" flat head Phillips screws

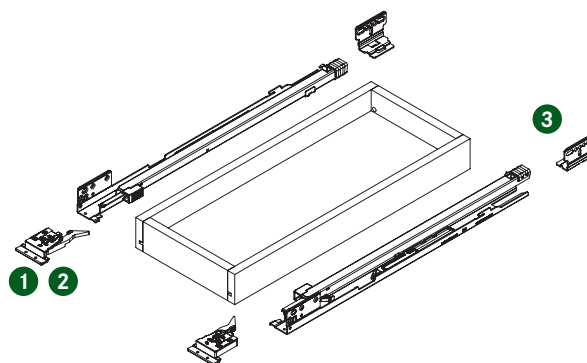

Drawer Installation Dimensions

Drawer Measurements

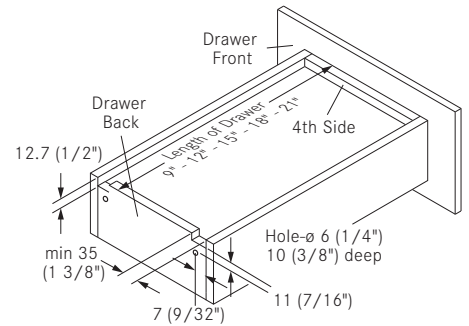
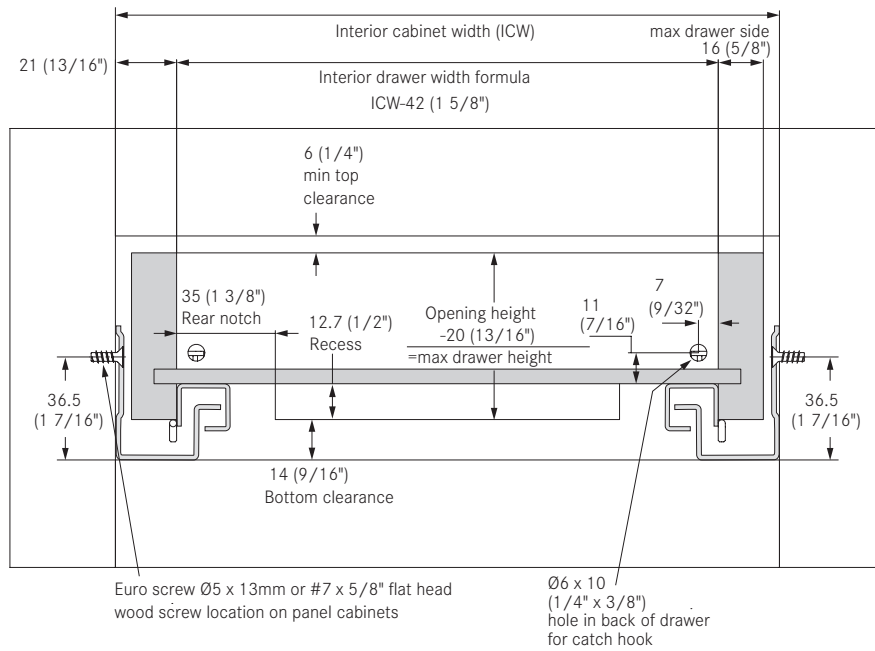

Cabinet Member Boring Specifications

Pre-drilling recommended Ø2.5mm (3/32").

Note: The recommendations for screw placement are guidelines only. Installers need to ensure that the cabinet wall is adequate.

min = minimum installation depth

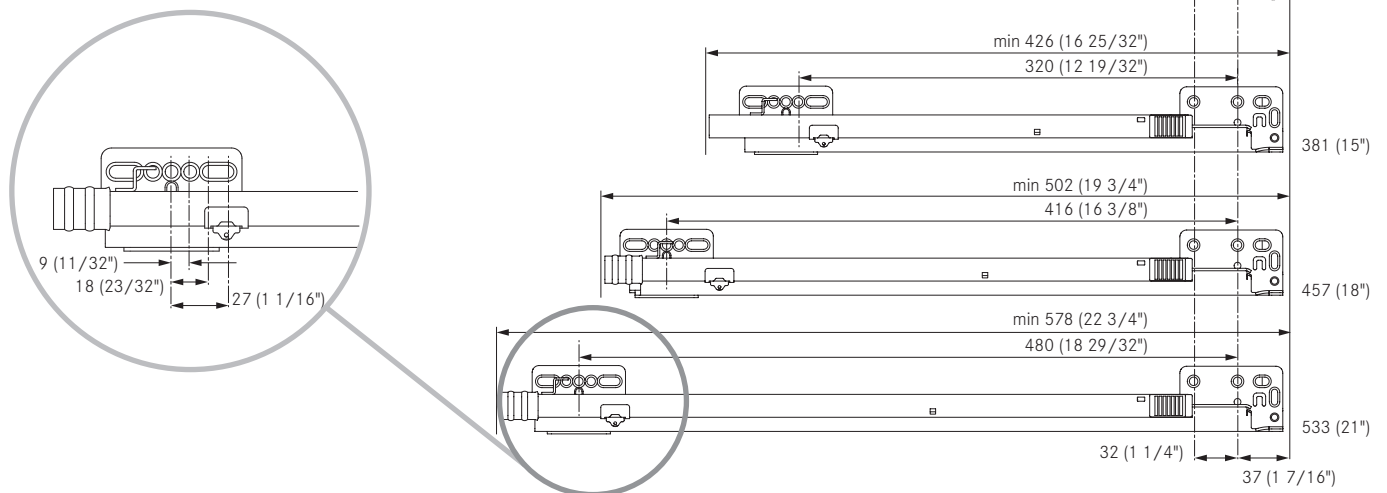

Maxcess 19, Face Frame

Full Access for 19mm (3/4") drawer material



- Face frame applications from 16mm (5/8") up to 19mm (3/4") drawer material
- Zinc plated, roll formed steel components
- Precision, smooth-running synthetic roller carriages
- German technology liquid damper with smooth closing action
- Self-latching front locking devices have easy release levers for drawer removal and installation
- Height adjustment +2.5mm (3/32") with suitable front locking device
- Side adjustment ±1.5mm (1/16") with suitable front locking device
- Weight capacity: 75 lb dynamic; 100 lb static
- Meets and exceeds ANSI/BHMA A156.9 Standard, Grade 1

Maxcess 19, Face Frame

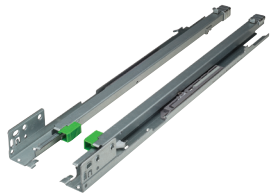

Drawer Length	Cab Mem Length	Min Installation Depth	Max Installation Depth	Item No.	PU
229 (9")	256 (10 3/32")	273 (10 3/4")	300 (11 13/16")	13306-03	5
305 (12")	316 (12 7/16")	349 (13 3/4")	360 (14 3/16")	13307-03	5
381 (15")	392 (15 7/16")	426 (16 25/32")	436 (17 5/32")	13308-03	5
457 (18")	468 (18 7/16")	502 (19 3/4")	512 (20 5/32")	13309-12	200
533 (21")	545 (21 15/32")	578 (22 3/4")	589 (23 3/16")	13310-12	200

Front Locking Devices and Rear Mounting Bracket

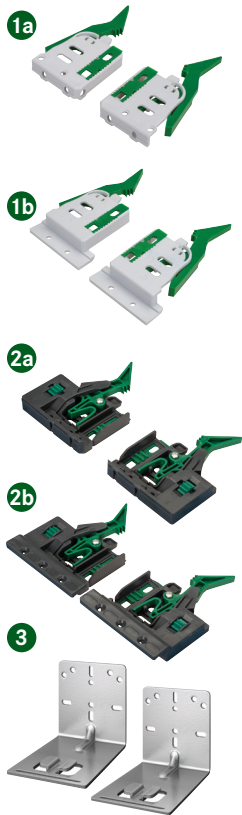

Description	Non-flanged Item No. (a)	Flanged Item No. (b)	PU
(Must order separately)			
1 7523 Front locking device, universal, 1D, kit*	02500-03	-	5
7523 Front locking device, universal, 1D, left	02498-12	02495-12	200
7523 Front locking device, universal, 1D, right	02499-12	02496-12	200
2 75X3 Front locking device, universal, 2D, left	80051-12	80053-12	200
75X3 Front locking device, universal, 2D, right	80052-12	80054-12	200
3 Universal rear mount bracket		7950.VE300	200

*Kit: Left/Right locking device, (4) #6 x 1/2" flat head Phillips screws

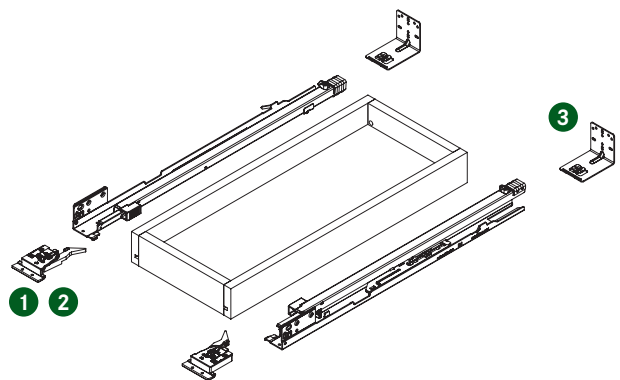

Drawer Installation Dimensions

Drawer Measurements

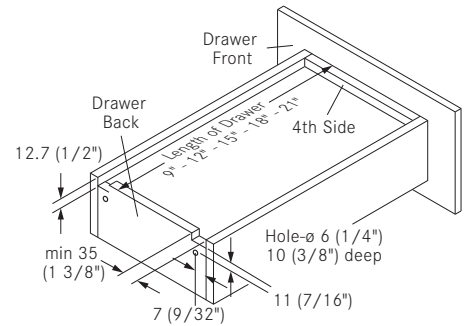
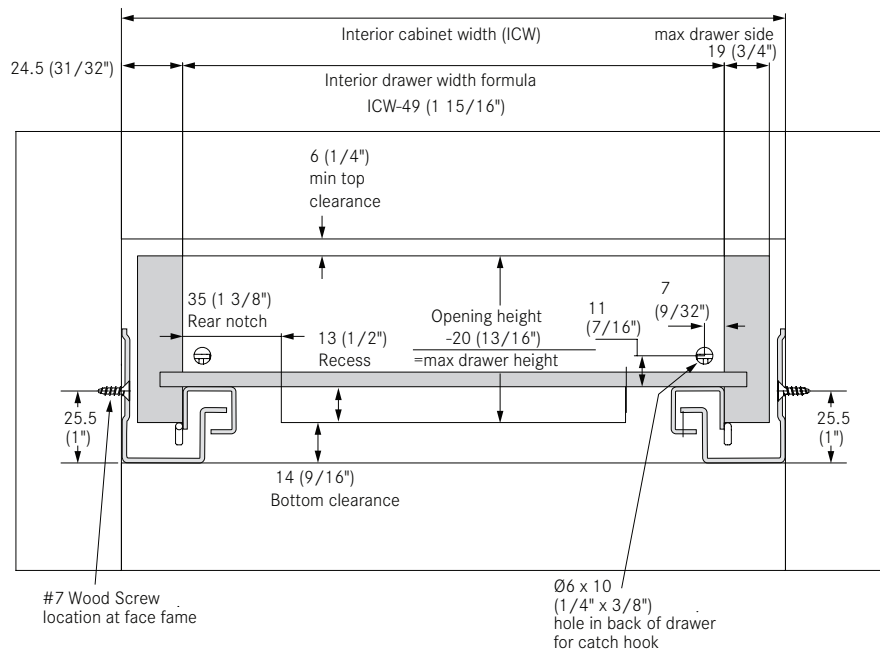

Rear Bracket Position

Cabinet Member Boring Specifications

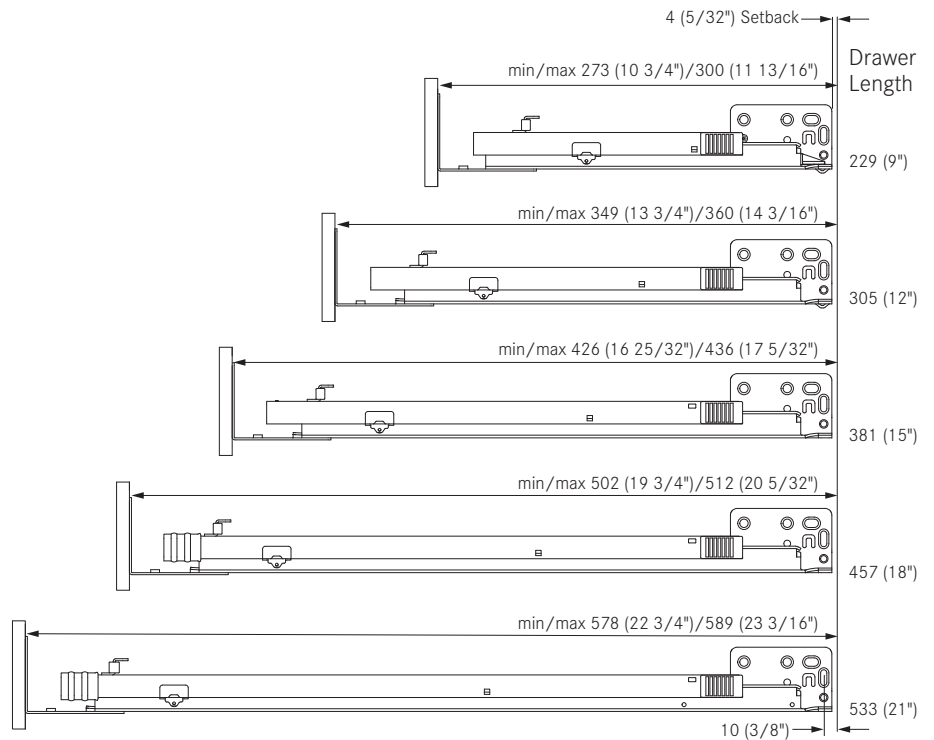
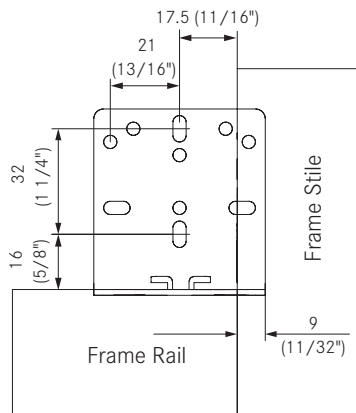

For face frame applications only. Use minimum of 3 screws per bracket, #6 x 1/2" truss head screws.

Pre-drilling recommended Ø2.5mm (3/32").
Note: The recommendations for screw placement are guidelines only. Installers need to ensure that the cabinet wall is adequate.

min/max = minimum/maximum installation depth

Accessories and Assembly Aids

Maxcess

Drilling Template



- Use to precisely bore holes in the drawer back
- Use with a standard 1/4" (6mm) drill bit and stop collar
- For use with Maxcess and Elite Plus

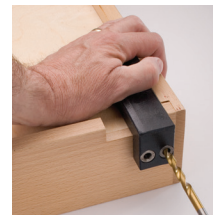

Left Side Drilling

Right Side Drilling

Description	Item No.	PU
Maxcess drilling template	02511-01	1

Assembly Aids



The non-flanged FLD drilling jig is used for mounting non-flange front locking devices to the drawer box for Dynapro, Elite Plus, and Maxcess.

The GRASS centering drill bit is used for pre-drilling countersink wood screws, Ø 2.5mm.



Description	Item No.	PU
1 Non-flanged FLD Drilling Jig	00004	1
2 Centering drill bit	35692-01	1

PU - Packaging unit

Maxcess

Screws

Euro Screw, Nickel-plated



Description	Item No.	PU
Euro Screw 11mm (7/16") Pozi	499.360.61.1015	500
Euro Screw 13mm (1/2") Pozi	499.360.61.3015	500

Wood Screw, Nickel-plated

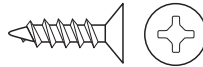

Description	Item No.	PU
#6 x 5/8" FHP, NI	81001-43	500
#6 x 3/4" FHP, NI	81003-43	500

Bumper Pads

Bumper Pads, Self-adhesive



Description	Item No.	PU
Bumper pad, clear, 2.5mm	63407-99	288
Bumper pad, clear, 2.5mm	63407-47	7200

AirSoft Bumper Pads, Self-adhesive



Description	Item No.	PU
AirSoft Bumper pad, clear, 5mm	63481-43	500
AirSoft Bumper pad, clear, 5mm	63483-30	5000

Bumper Pads, Self-adhesive



Description	Item No.	PU
Bumper pad, clear, 7mm	630.000.03.0750	1088
Bumper pad, clear, 10mm	630.000.03.1050	1050
Bumper pad, clear, 12mm	630.000.02.1250	5000

Bumper Pads, Self-adhesive



Description	Item No.	PU
Bumper pad, clear, 3mm	31002-43	500
Bumper pad, clear, 1.5mm	31004-43	500

PU - Packaging unit



GRASS America Inc.
1202 NC Highway 66 South
Kernersville, NC 27284

Phone: 1-800-334-3512
Fax: 1-800-525-8406

www.grassusa.com
info@grassusa.com

