

PRO Super Rail Soft-Close Slide



45mm Series Soft-Close Round Profile Full Extension Ball Bearing Slides - Metric Series

Product



Description

- Load capacity: 45kg
- Finish: Blue Zinc Plated (B02), Black (D01)
- Lengths: 300 - 600mm
- Full extension
- Soft-close
- Single way travel

Space Requirement

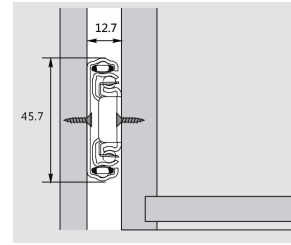

Order Information

Installation Dimensions (mm)

NL= Nominal Slide Length
LT= Internal Cabinet Depth

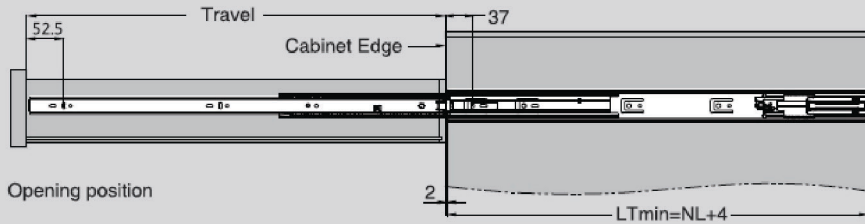

Metal Rear Bracket



Pcs/ctn: 100 Item #: PRO100SC-xxBM

Screw Positions of the Slides (mm)

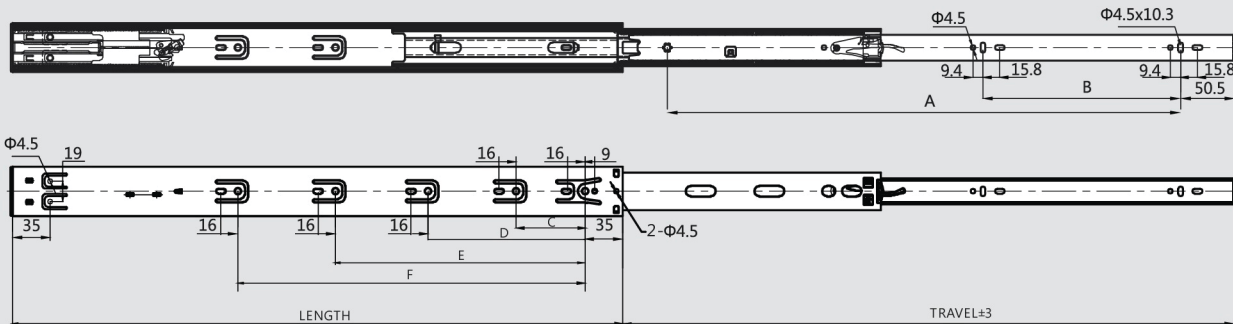

Installation Dimensions (mm)

Item #	Length NL	Travel	Hole Pattern						Set/ctn
			A	B	C	D	E	F	
PRO100SC-10	250	163.8	174						12
PRO100SC-12	300	263.8	224	64	96				12
PRO100SC-14	350	335.3	256	96	64	128			12
PRO100SC-16	400	401	320	128	64	128	192		12
PRO100SC-18	450	451	352	160	64	128	224		12
PRO100SC-20	500	501	416	192	64	128	256		12
PRO100SC-22	550	551	448	224	64	128	224	320	12
PRO100SC-24	600	601	512	224	64	128	224	352	12

Würth Louis and Company

www.wurthlac.com • 800-422-4389

OPT-OUT INFORMATION: You may request Würth Louis and Company not to send any future advertisements to a telephone facsimile machine or machines. Failure to comply with such a request in the form prescribed by law, within the shortest time prescribed by law not to exceed 30 days, is unlawful. If you wish to discontinue future fax advertisements from Würth Louis and Company, please send your request by Email to: creditdepartment@wurthlac.com, or by Fax to: 800-944-7494 or by Calling: 800-444-0043 option 2. Your request should specify the telephone numbers or numbers of each telephone facsimile machine to which the request relates.