

4

3

2

1

B

B

A

A

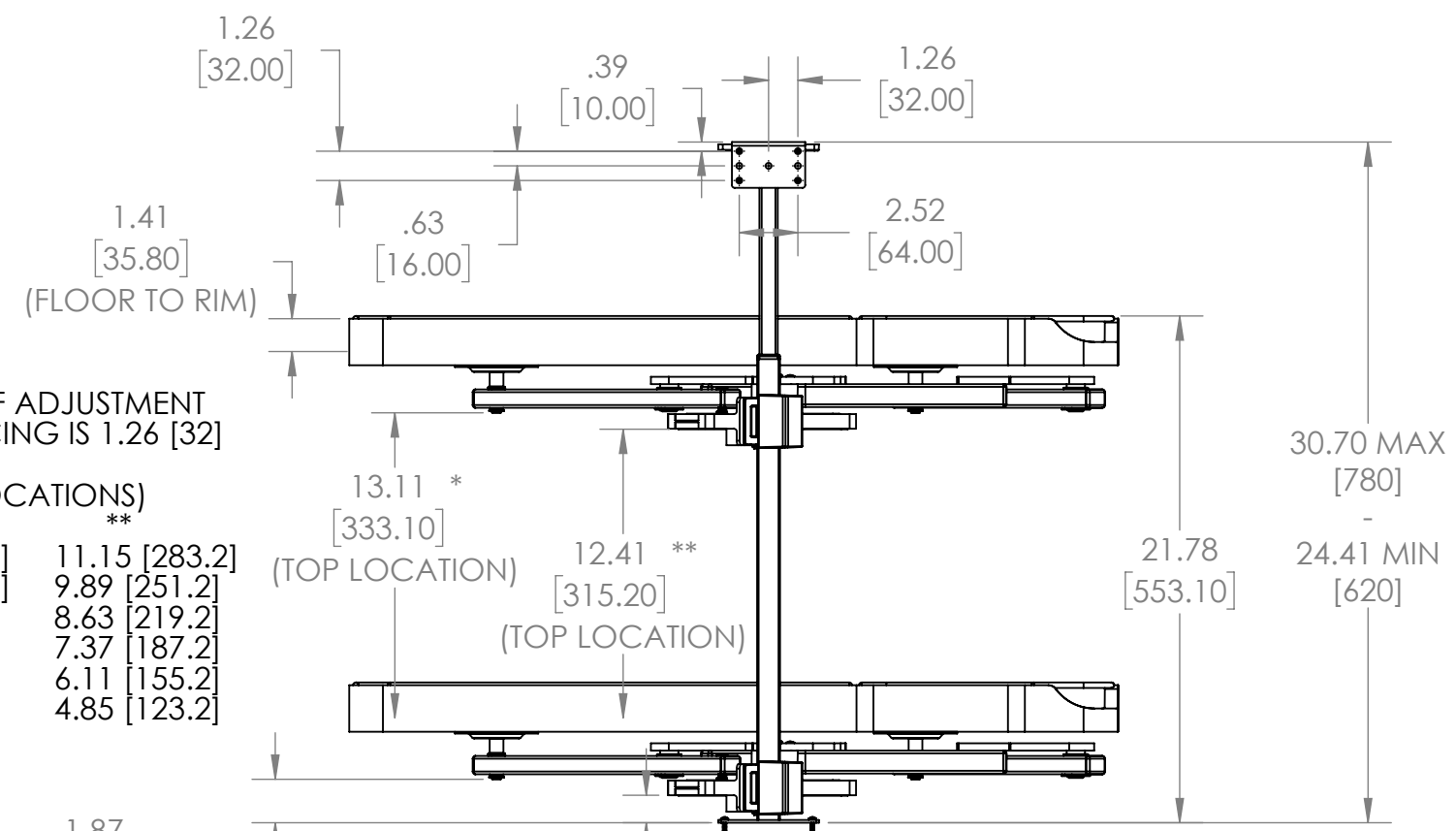
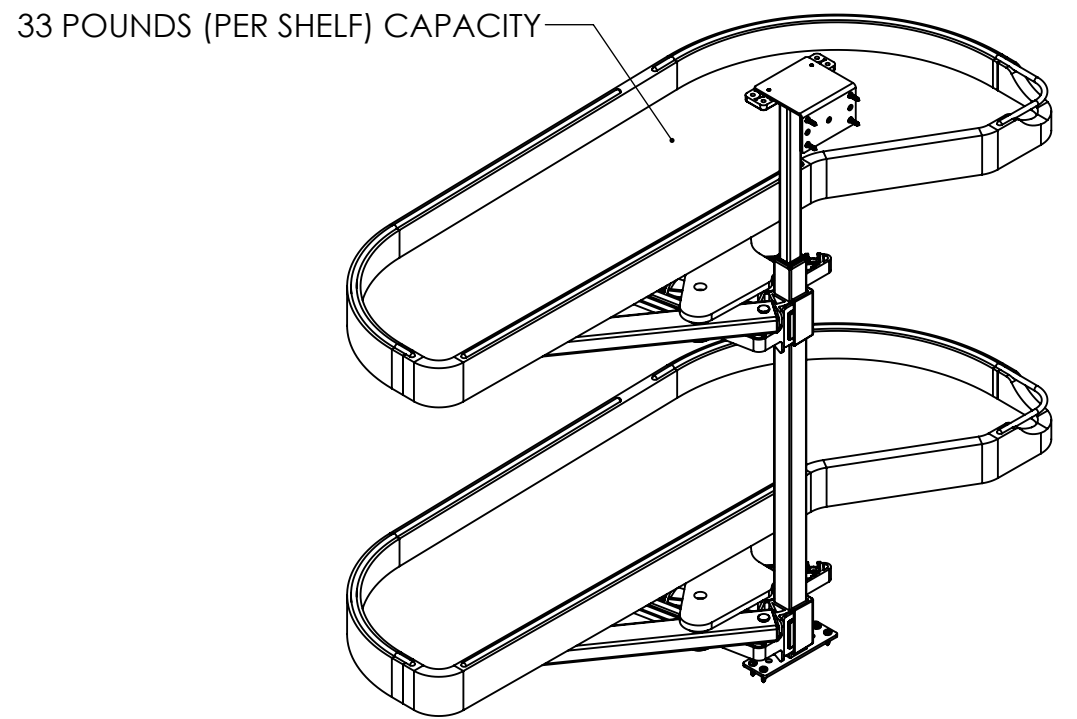
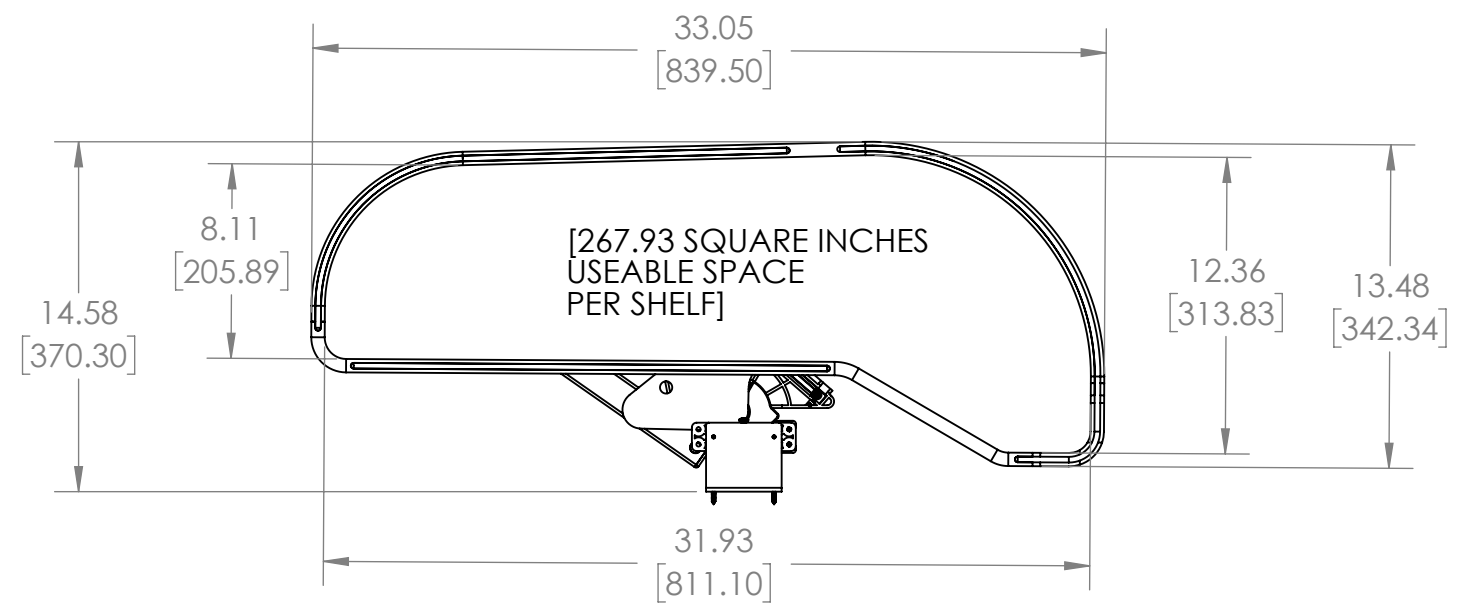

NOTE: SHELF ADJUSTMENT SPACING IS 1.26 [32]

(LOWER LOCATIONS)

11.85 [301.1]	11.15 [283.2]
10.59 [269.1]	9.89 [251.2]
9.33 [237.1]	8.63 [219.2]
8.07 [205.1]	7.37 [187.2]
6.81 [173.1]	6.11 [155.2]
5.55 [141.1]	4.85 [123.2]

BOTTOM VIEW

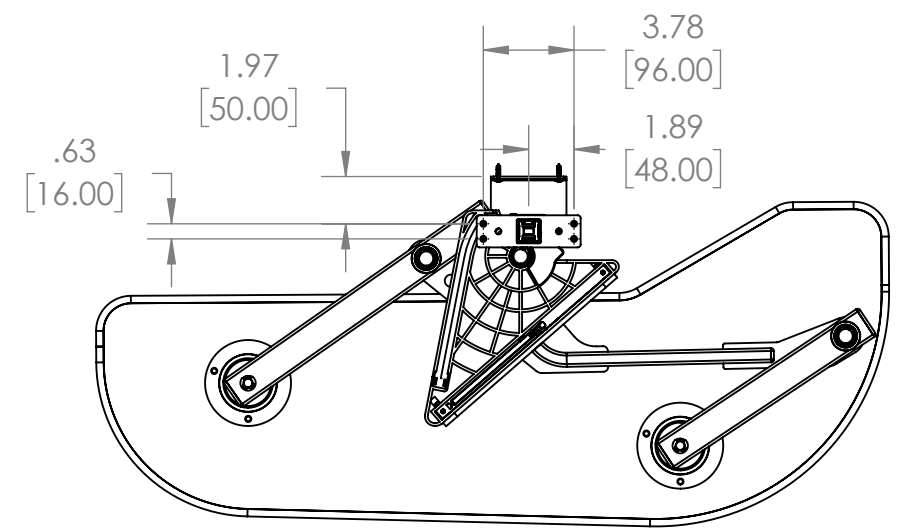

CUSTOMER DRAWING

UNCONTROLLED IF PRINTED



PROPRIETARY AND CONFIDENTIAL
 This drawing is the property of Rev-A-Shelf LLC (RAS) and is disclosed in confidence to the extent its subject matter is original to RAS. Any vendor receiving this drawing from RAS shall hold and use this drawing for the sole benefit of RAS and shall not disclose it to, or use or reproduce it for any third party, or perform any act adverse to the interest of RAS with respect to this drawing without the express written permission of RAS. Vendors shall not revise any physical, dimensional or performance characteristic unless authorized by Rev-A-Shelf Engineering.

REV	DATE	BY	DESCRIPTION OF CHANGE

UNLESS OTHERWISE SPECIFIED:		Description:	
TOLERANCES = INCH/(MM) MAT. DEC. (WOOD) .XX +/--.03 [8mm] (OTHER) .XX +/--.02 [5mm] (ALL) .XXX +/--.005 [13 mm] FRACTIONS +/-1/32 [8 mm] ANGLES +/-1/2°		2-TIER CRAFTSMAN COLLECTION WOOD PULLOUT RIGHT DOOR/BLIND LEFT	
Third Angle Projection		PART NO. 487CC-12-RMB	
MATERIAL	FINISH	SIZE	DWG. NO.
DO NOT SCALE DRAWING	NAME	B	487CC-12-RMB
DRAWN	KRR	DATE	12-18-24
SCALE: 1:8	WEIGHT:	SHEET 1 OF 3	

4

3

2

1

4

3

2

1

B

B

A

A

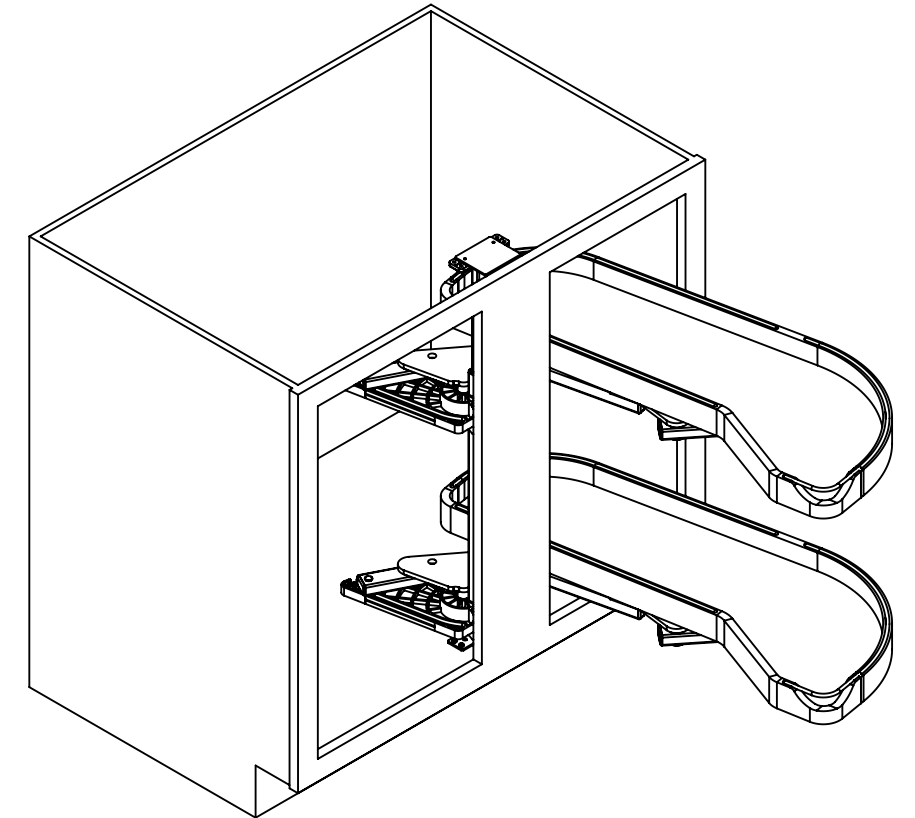
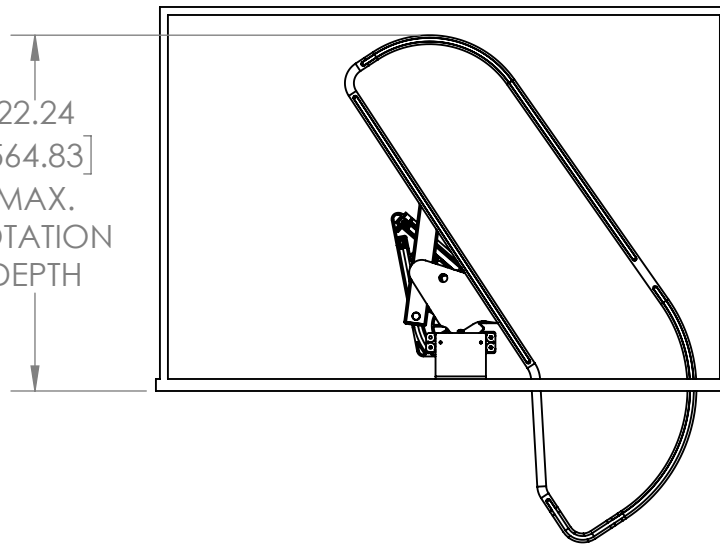
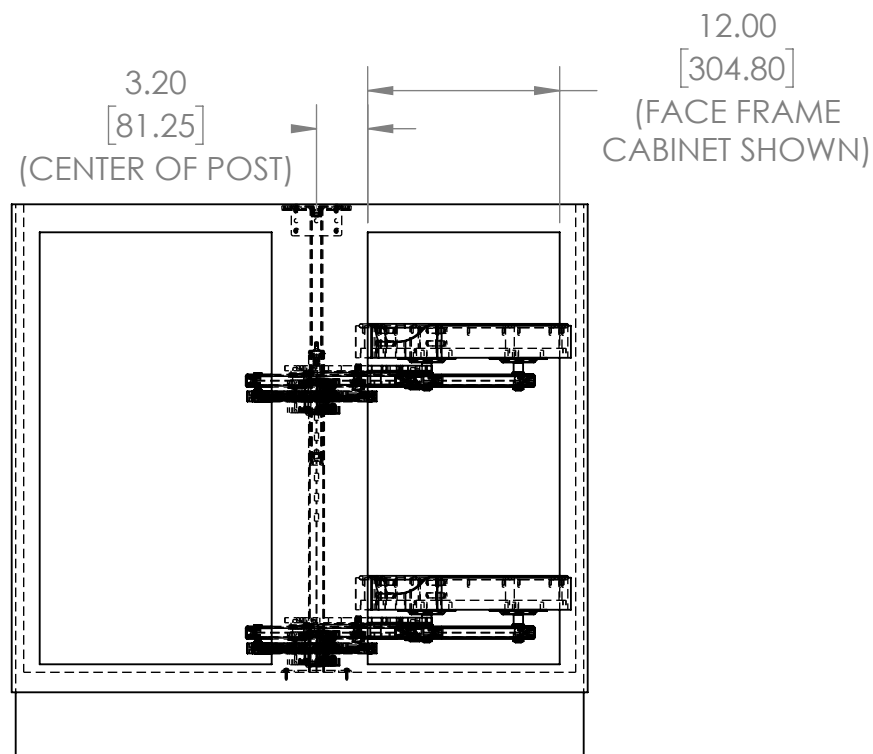
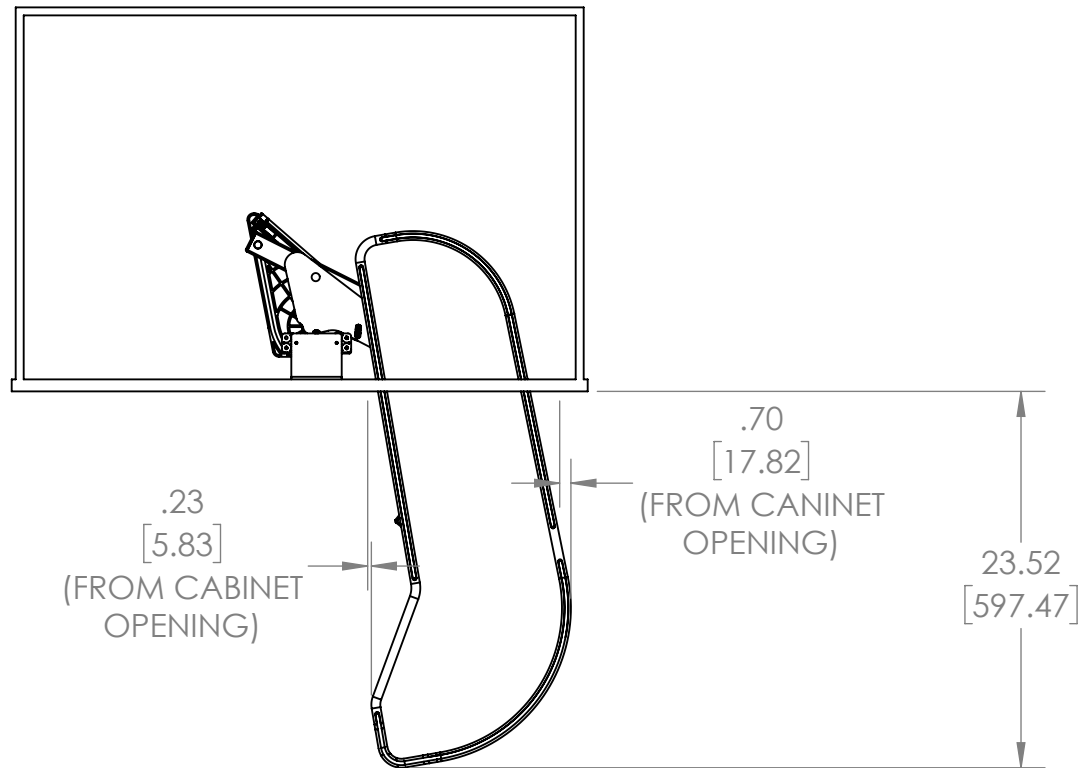

PROPRIETARY AND CONFIDENTIAL
 This drawing is the property of Rev-A-Shelf LLC (RAS) and is disclosed in confidence to the extent its subject matter is original to RAS. Any vendor receiving this drawing from RAS shall hold and use this drawing for the sole benefit of RAS and shall not disclose it to, or use or reproduce it for any third party, or perform any act adverse to the interest of RAS with respect to this drawing without the express written permission of RAS. Vendors shall not revise any physical, dimensional or performance characteristic unless authorized by Rev-A-Shelf Engineering.

UNCONTROLLED IF PRINTED

REV	DATE	BY	DESCRIPTION OF CHANGE

UNLESS OTHERWISE SPECIFIED:		Description:	
TOLERANCES = INCH/(MM) MAT. DEC. (WOOD) .XX +/--.03 [.8mm] (OTHER) .XX +/--.02 [.5mm] (ALL) .XXX +/--.005 [.13 mm] FRACTIONS +/-1/32 [.8 mm] ANGLES +/-1/2°		2-TIER CRAFTSMAN COLLECTION WOOD PULLOUT RIGHT DOOR/BLIND LEFT	
First Angle Projection		PART NO. 487CC-12-RMB	
MATERIAL	FINISH	SIZE	DWG. NO.
DO NOT SCALE DRAWING	NAME	B	487CC-12-RMB
DRAWN	KRR	DATE	12-18-24
SCALE: 1:12		WEIGHT:	SHEET 2 OF 3

4

3

2

1

4

3

2

1

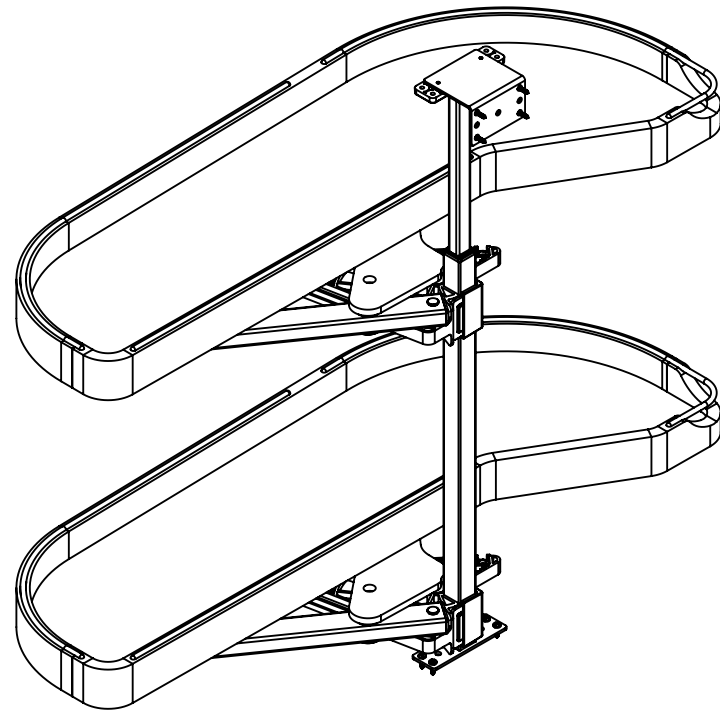

PART DIMENSIONS	
WIDTH	33.05 [839.50]
DEPTH	14.58 [370.30]
HEIGHT	24.41 [620] MIN.

MIN CABINET OPENING				
	FACE FRAME	FRAMELESS	INSET FACE FRAME	INSET FRAMELESS
WIDTH	12.00 [304.8]	13.50 [342.9]	12.00 [304.8]	13.50 [342.9]
DEPTH	22.50 [571.5]	22.50 [571.5]	22.50 [571.5]	22.50 [571.5]
HEIGHT *	18.50 [469.9]	18.50 [469.9]	18.50 [469.9]	18.50 [469.9]

* NOTE: THIS HEIGHT LEAVES 4.28" ABOVE TRAY AT ITS LOWEST POSITION.

CUSTOMER DRAWING

UNCONTROLLED IF PRINTED



PROPRIETARY AND CONFIDENTIAL
 This drawing is the property of Rev-A-Shelf LLC (RAS) and is disclosed in confidence to the extent its subject matter is original to RAS. Any vendor receiving this drawing from RAS shall hold and use this drawing for the sole benefit of RAS and shall not disclose it to, or use or reproduce it for any third party, or perform any act adverse to the interest of RAS with respect to this drawing without the express written permission of RAS. Vendors shall not revise any physical, dimensional or performance characteristic unless authorized by Rev-A-Shelf Engineering.

REV	DATE	BY	DESCRIPTION OF CHANGE

UNLESS OTHERWISE SPECIFIED:		Description:	
TOLERANCES = INCH/(MM) MAT. DEC. (WOOD) .XX +/- .03 [.8mm] (OTHER) .XX +/- .02 [.5mm] (ALL) .XXX +/- .005 [.13 mm] FRACTIONS +/- 1/32 [.8 mm] ANGLES +/- 1/2°		2-TIER CRAFTSMAN COLLECTION WOOD PULLOUT RIGHT DOOR/BLIND LEFT	
First Angle Projection		PART NO. 487CC-12-RMB	
MATERIAL	FINISH	SIZE B	DWG. NO. 487CC-12-RMB
DO NOT SCALE DRAWING	NAME	DATE	SCALE: 1:8 WEIGHT: SHEET 3 OF 3
DRAWN	KRR	12-18-24	

4

3

2

1

B

B

A

A