

4

3

2

1

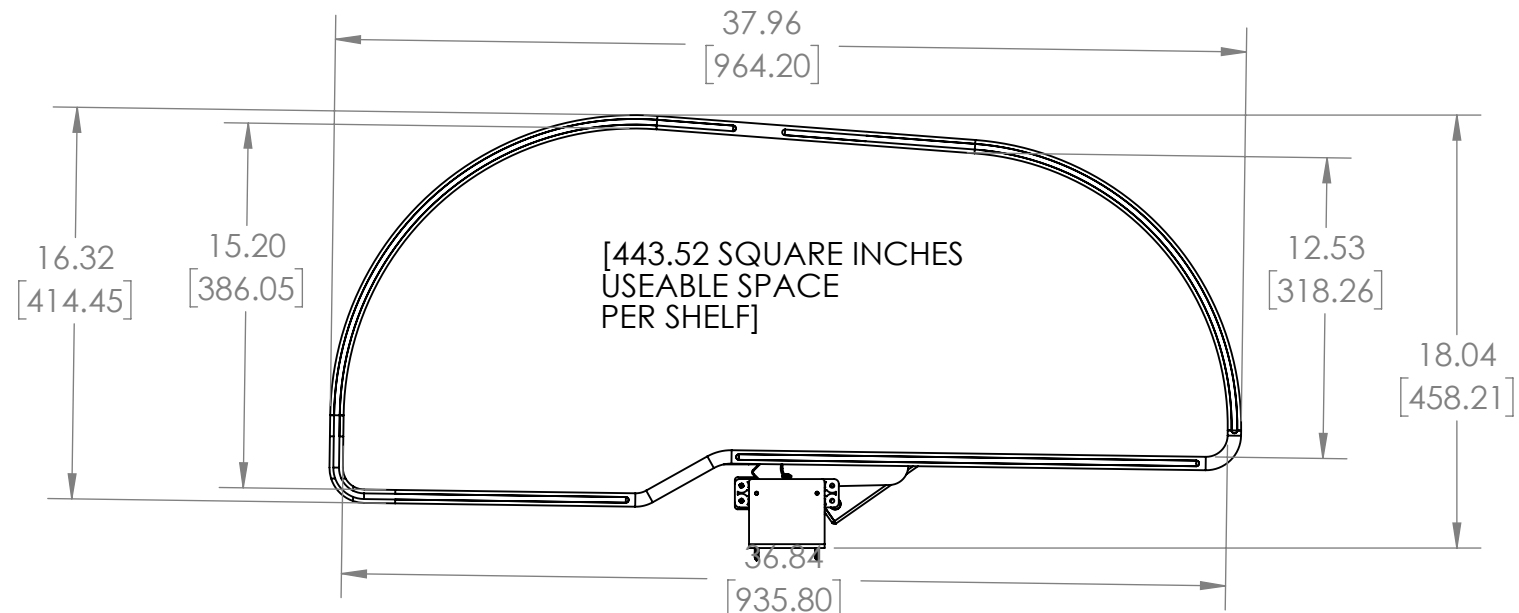

33 POUNDS (PER SHELF) CAPACITY

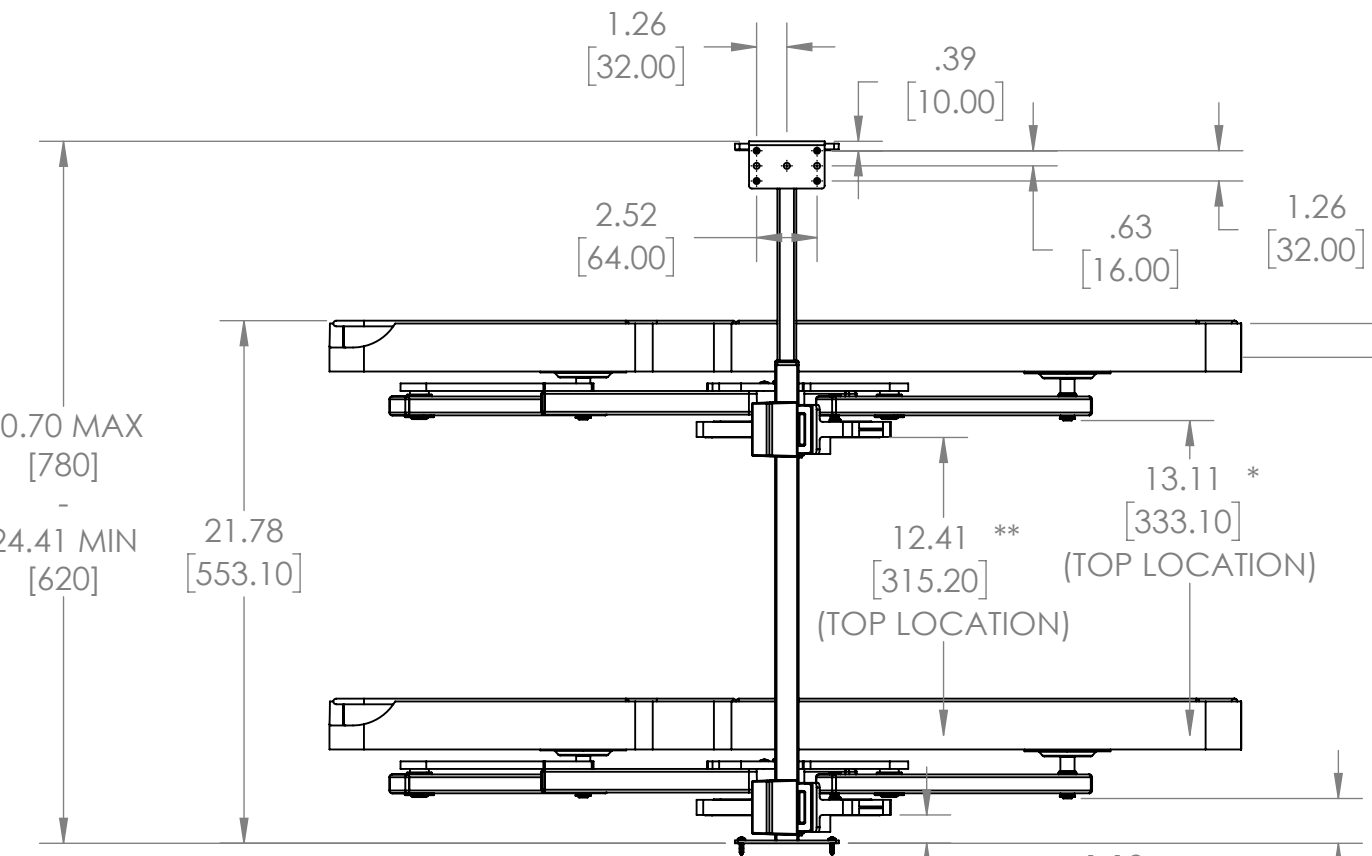
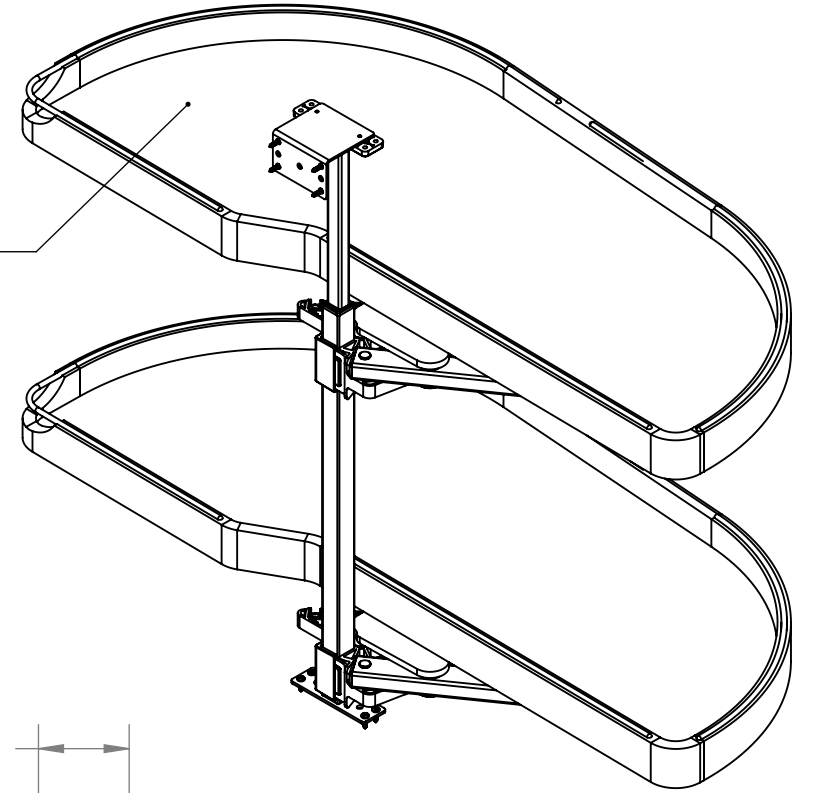

NOTE: SHELF ADJUSTMENT SPACING IS 1.26 [32]

(LOWER LOCATIONS)

*	**
11.85 [301.1]	11.15 [283.2]
10.59 [269.1]	9.89 [251.2]
9.33 [237.1]	8.63 [219.2]
8.07 [205.1]	7.37 [187.2]
6.81 [173.1]	6.11 [155.2]
5.55 [141.1]	4.85 [123.2]

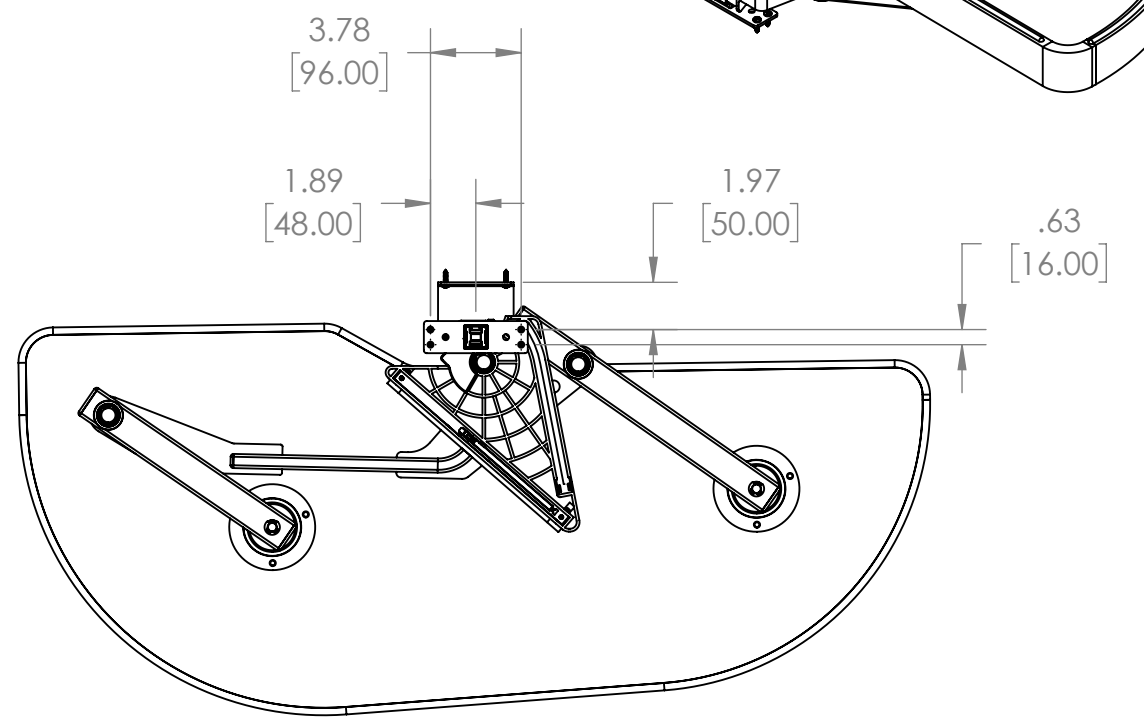

BOTTOM VIEW

CUSTOMER DRAWING

UNCONTROLLED IF PRINTED



PROPRIETARY AND CONFIDENTIAL
 This drawing is the property of Rev-A-Shelf LLC (RAS) and is disclosed in confidence to the extent its subject matter is original to RAS. Any vendor receiving this drawing from RAS shall hold and use this drawing for the sole benefit of RAS and shall not disclose it to, or use or reproduce it for any third party, or perform any act adverse to the interest of RAS with respect to this drawing without the express written permission of RAS. Vendors shall not revise any physical, dimensional or performance characteristic unless authorized by Rev-A-Shelf Engineering.

REV	DATE	BY	DESCRIPTION OF CHANGE

UNLESS OTHERWISE SPECIFIED:			
TOLERANCES = INCH/(MM)			
MAT. DEC.			
(WOOD) .XX +/--.03 [8mm]			
(OTHER) .XX +/--.02 [5mm]			
(ALL) .XXX +/--.005 [13 mm]			
FRACTIONS +/-1/32 [8 mm]			
ANGLES +/-1/2°			
Third Angle Projection			
MATERIAL	FINISH		
DO NOT SCALE DRAWING	NAME	DATE	
DRAWN	KRR	12-19-24	

Description:			
2-TIER CRAFTSMAN COLLECTION			
WOOD PULLOUT LEFT			
DOOR/BLIND RIGHT			
PART NO. 487CC-18-LMB			
SIZE	DWG. NO.		
B	487CC-18-LMB		
SCALE: 1:8	WEIGHT:	SHEET 1 OF 3	

4

3

2

1

4

3

2

1

B

B

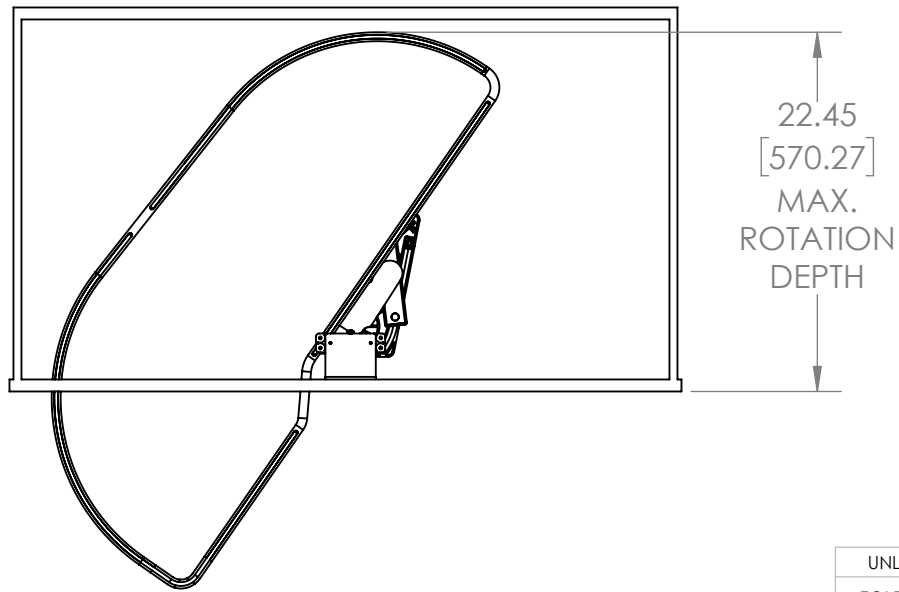
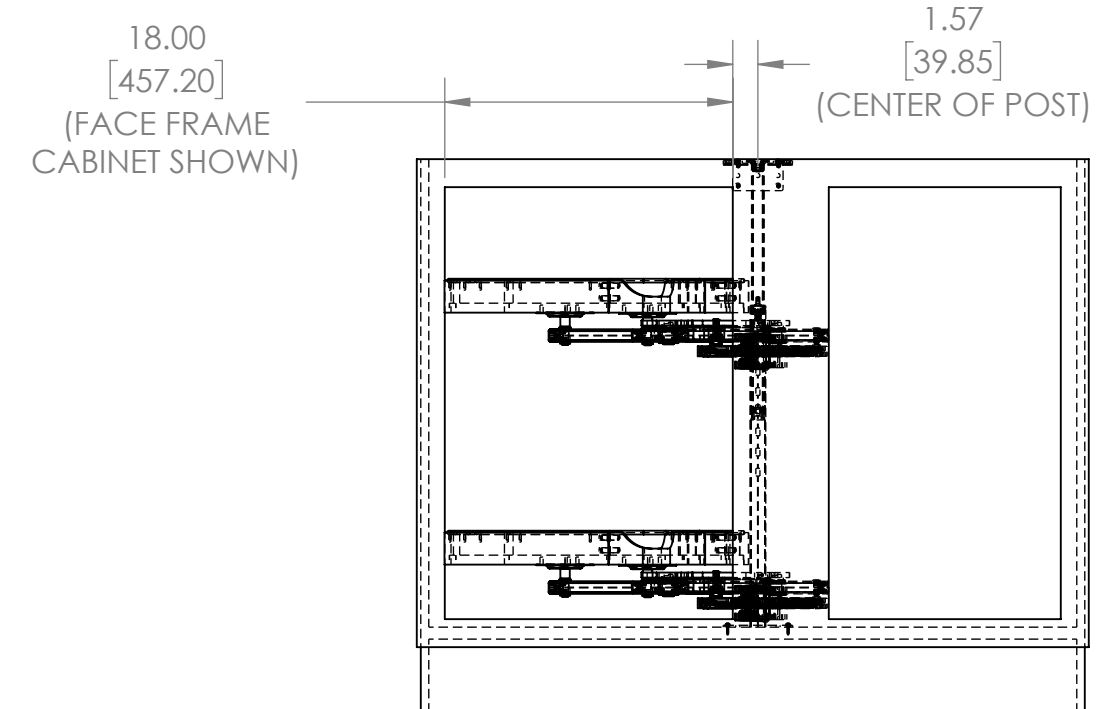
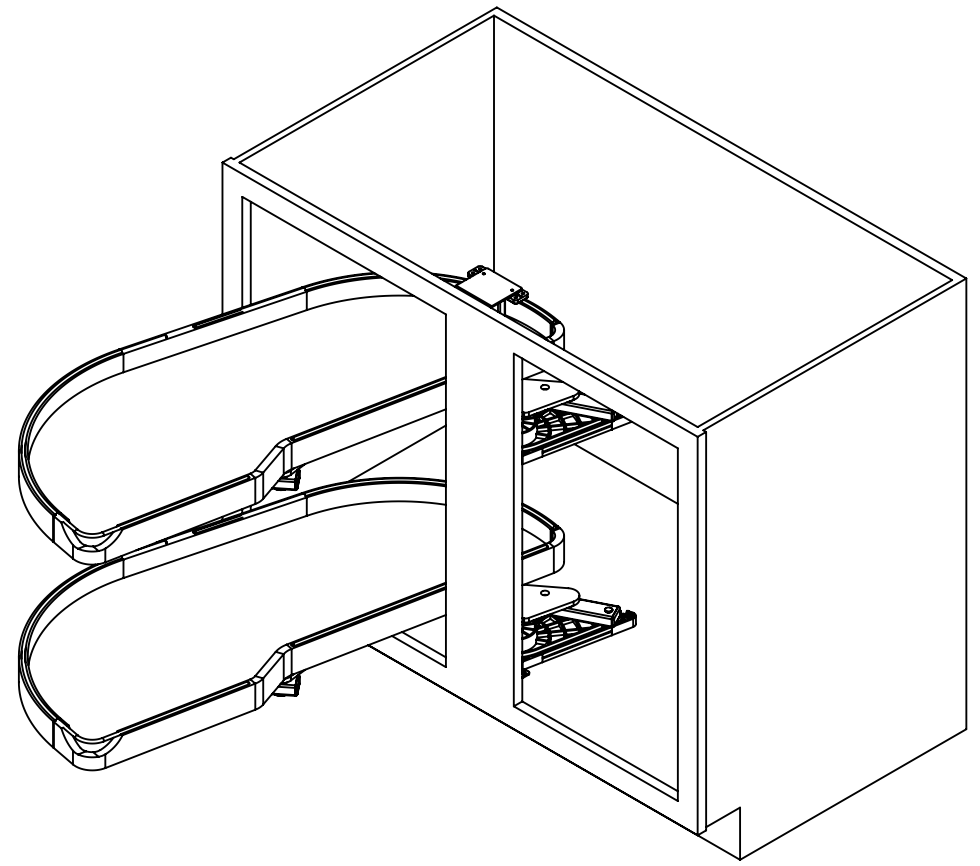
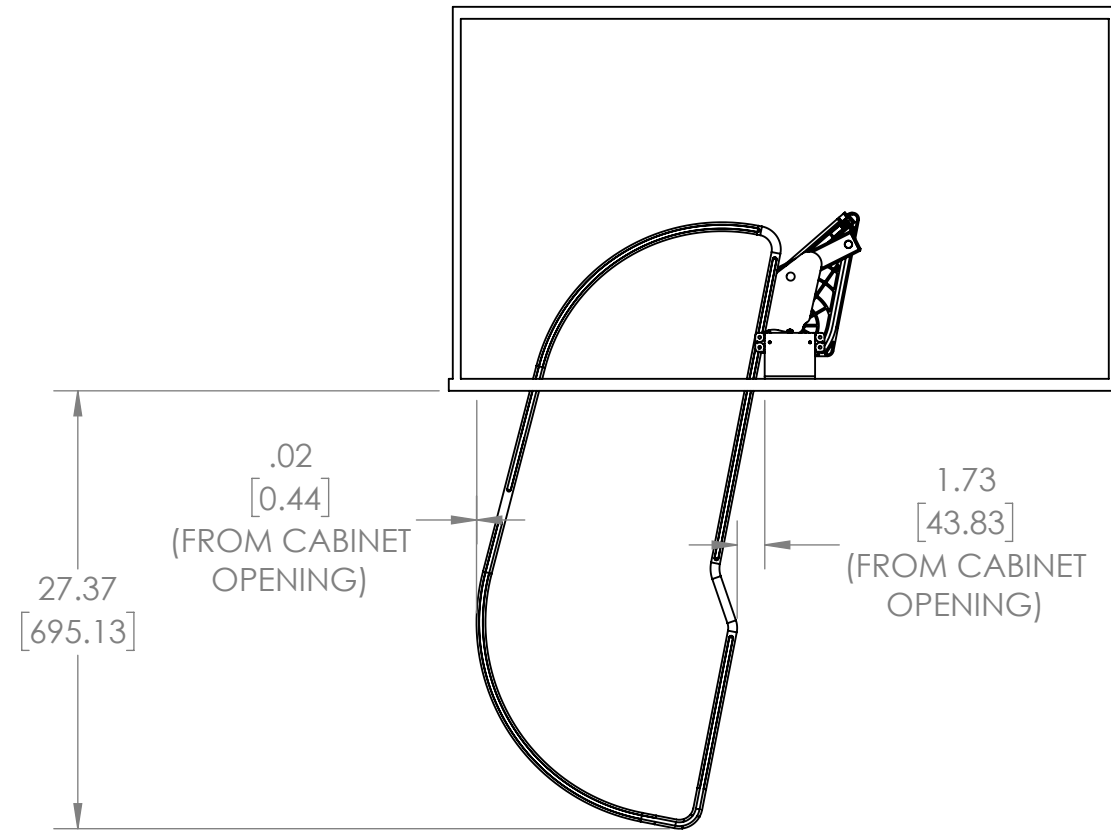

A

A

CUSTOMER DRAWING

UNCONTROLLED IF PRINTED

REV-A-SHELF
 PROPRIETARY AND CONFIDENTIAL
 This drawing is the property of Rev-A-Shelf LLC (RAS) and is disclosed in confidence to the extent its subject matter is original to RAS. Any vendor receiving this drawing from RAS shall hold and use this drawing for the sole benefit of RAS and shall not disclose it to, or use or reproduce it for any third party, or perform any act adverse to the interest of RAS with respect to this drawing without the express written permission of RAS. Vendors shall not revise any physical, dimensional or performance characteristic unless authorized by Rev-A-Shelf Engineering.

REV	DATE	BY	DESCRIPTION OF CHANGE

UNLESS OTHERWISE SPECIFIED:		Description:	
TOLERANCES = INCH/(MM) MAT. DEC. (WOOD) .XX +/--.03 [.8mm] (OTHER) .XX +/--.02 [.5mm] (ALL) .XXX +/--.005 [.13 mm] FRACTIONS +/-1/32 [.8 mm] ANGLES +/-1/2°		2-TIER CRAFTSMAN COLLECTION WOOD PULLOUT LEFT DOOR/BLIND RIGHT	
First Angle Projection		PART NO. 487CC-18-LMB	
MATERIAL	FINISH	SIZE	DWG. NO.
DO NOT SCALE DRAWING	NAME	B	487CC-18-LMB
DRAWN	KRR	12-19-24	SCALE: 1:12 WEIGHT:
			SHEET 2 OF 3

4

3

2

1

4

3

2

1

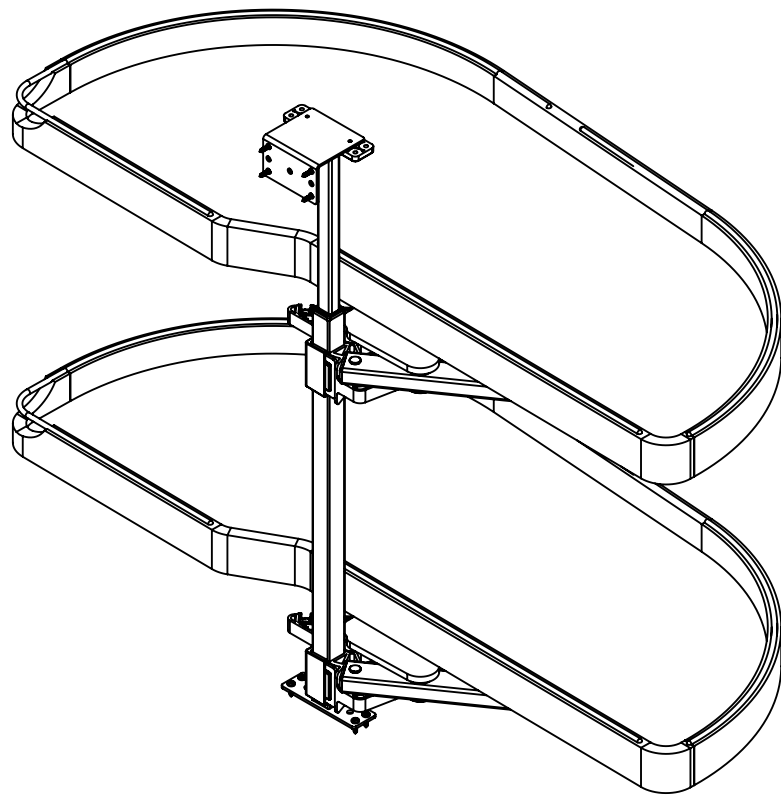

PART DIMENSIONS	
WIDTH	37.96 [964.20]
DEPTH	18.04 [458.21]
HEIGHT	24.41 [620] MIN

MIN CABINET OPENING				
	FACE FRAME	FRAMELESS	INSET FACE FRAME	INSET FRAMELESS
WIDTH	18.00 [547.2]	19.50 [495.3]	18.00 [547.2]	19.50 [495.3]
DEPTH	23.00 [584.2]	23.00 [584.2]	23.00 [584.2]	23.00 [584.2]
HEIGHT *	18.50 [469.9]	18.50 [469.9]	18.50 [469.9]	18.50 [469.9]

* NOTE: THIS HEIGHT LEAVES 4.28" ABOVE TRAY AT ITS LOWEST POSITION.

CUSTOMER DRAWING

UNCONTROLLED IF PRINTED



PROPRIETARY AND CONFIDENTIAL

This drawing is the property of Rev-A-Shelf LLC (RAS) and is disclosed in confidence to the extent its subject matter is original to RAS. Any vendor receiving this drawing from RAS shall hold and use this drawing for the sole benefit of RAS and shall not disclose it to, or use or reproduce it for any third party, or perform any act adverse to the interest of RAS with respect to this drawing without the express written permission of RAS. Vendors shall not revise any physical, dimensional or performance characteristic unless authorized by Rev-A-Shelf Engineering.

REV	DATE	BY	DESCRIPTION OF CHANGE

UNLESS OTHERWISE SPECIFIED:		Description:	
TOLERANCES = INCH/(MM) MAT. DEC. (WOOD) .XX +/--.03 [.8mm] (OTHER) .XX +/--.02 [.5mm] (ALL) .XXX +/--.005 [.13 mm] FRACTIONS +/-1/32 [.8 mm] ANGLES +/-1/2°		2-TIER CRAFTSMAN COLLECTION WOOD PULLOUT LEFT DOOR/BLIND RIGHT	
First Angle Projection		PART NO. 487CC-18-LMB	
MATERIAL	FINISH	SIZE	DWG. NO.
		B	487CC-18-LMB
DO NOT SCALE DRAWING	NAME	DATE	SCALE: 1:8
	KRR	12-19-24	WEIGHT:
DRAWN		SHEET 3 OF 3	

4

3

2

1

B

B

A

A