



OPERATOR'S MANUAL FOR 10,000 OPM 3 x 4 in. (75 x 100 mm) ORBITAL SANDERS

Declaration of conformity
DIXON ENTERPRISES, INC.
571 BIRCH STREET LAKE ELSINORE, CA 92530
declare on our sole responsibility that the products

3 in. x 4 in. 10,000 OPM Orbital Sanders (See "Product Configuration/Specifications" Table for particular Model) to which this declaration relates is in conformity with the following standard(s) or other normative document(s) EN ISO 15744:2008. Following the provisions of 89/392/EEC as amended by 91/368/EEC & 93/44/EEC 93/68/EEC Directives and consolidating Directive 2006/42/EC

03.22.2013
Place and date of issue

Meri Faria
Name

Meri Faria
Signature or equivalent marking of authorized person

<p>Operator Instructions</p> <p>Includes – Please Read and Comply, Proper Use of Tool, Warranty, Product Configuration and Specifications Table, Parts Page, Parts List, Work Stations, Putting the Tool Into Service, Operating Instructions and Compressor Layout, Back-Up Pads, Service Tools and Accessories, Overhaul Service Kit, Spare Part Kits, Service Instructions.</p>	<p>Important</p> <p>Read these instructions carefully before installing, operating, servicing or repairing this tool. Keep these instructions in a safe accessible location.</p>							
<p>Manufacturer/Supplier DIXON ENTERPRISES, INC. 571 BIRCH STREET LAKE ELSINORE, CA 92530 Tel: 951-245-4200 Fax: 951-245-4299</p>	<p style="text-align: center;">Required Personal Safety Equipment</p> <table style="width: 100%; border: none;"> <tr> <td style="padding: 5px;">Safety Glasses</td> <td style="padding: 5px;">Breathing Masks</td> </tr> <tr> <td style="padding: 5px;">Safety Gloves</td> <td style="padding: 5px;">Ear Protection</td> </tr> </table>		Safety Glasses	Breathing Masks	Safety Gloves	Ear Protection		
Safety Glasses	Breathing Masks							
Safety Gloves	Ear Protection							
<p>Recommended Airline Size - Minimum 10 mm 3/8 in</p>	<p>Recommended Maximum Hose Length 8 meters 25 feet</p>	<p style="text-align: center;">Air Pressure</p> <table style="width: 100%; border: none;"> <tr> <td style="padding: 5px;">Maximum Working Pressure</td> <td style="padding: 5px;">6.2 bar</td> <td style="padding: 5px;">90 psig</td> </tr> <tr> <td style="padding: 5px;">Recommended Minimum</td> <td style="padding: 5px;">NA</td> <td style="padding: 5px;">NA</td> </tr> </table>	Maximum Working Pressure	6.2 bar	90 psig	Recommended Minimum	NA	NA
Maximum Working Pressure	6.2 bar	90 psig						
Recommended Minimum	NA	NA						

Please Read and Comply with:

- 1) General Industry Safety & Health Regulations, Part 1910, OSHA 2206, available from: Superintendent of Documents; Government Printing Office; Washington DC 20402
- 2) Safety Code for Portable Air Tools, ANSI B186.1 available from: American National Standards Institute, Inc.; 1430 Broadway; New York, New York 10018
- 3) State and Local Regulations.

Proper Use of Tool

This sander is designed for sanding all types of materials i.e. metals, wood, stone, plastics, etc. using abrasive designed for this purpose. Do not use this sander for any other purpose than that specified without consulting the manufacturer or the manufacturer's authorized supplier.

Do not use back-up pads that have a working speed less than 10,000 OPM free speed. Never use back-up pads that have a weight and/or size different than the machine was specifically designed for.

Warranty

All SurfPrep™ Orbital Sanders are warranted for defects in materials or workmanship for one year from the date of delivery to the user. Combined with the SurfPrep™ name, this Warranty expresses our total confidence in the superior quality, durability, and performance of the SurfPrep™ LP. To receive any expressed or implied warranty, tool must be repaired by an authorized SurfPrep™ Service Center. The "Service Instructions" section in this document is provided for use after completion of the warranty period. To receive warranty, tools must be operated under the conditions as described in the "Putting the Tools into Service" section of this document and be connected to an air supply system as shown in Figure 1. Tools that have been exposed to extreme conditions will be covered under warranty at the sole discretion of SurfPrep™.

Parts Page

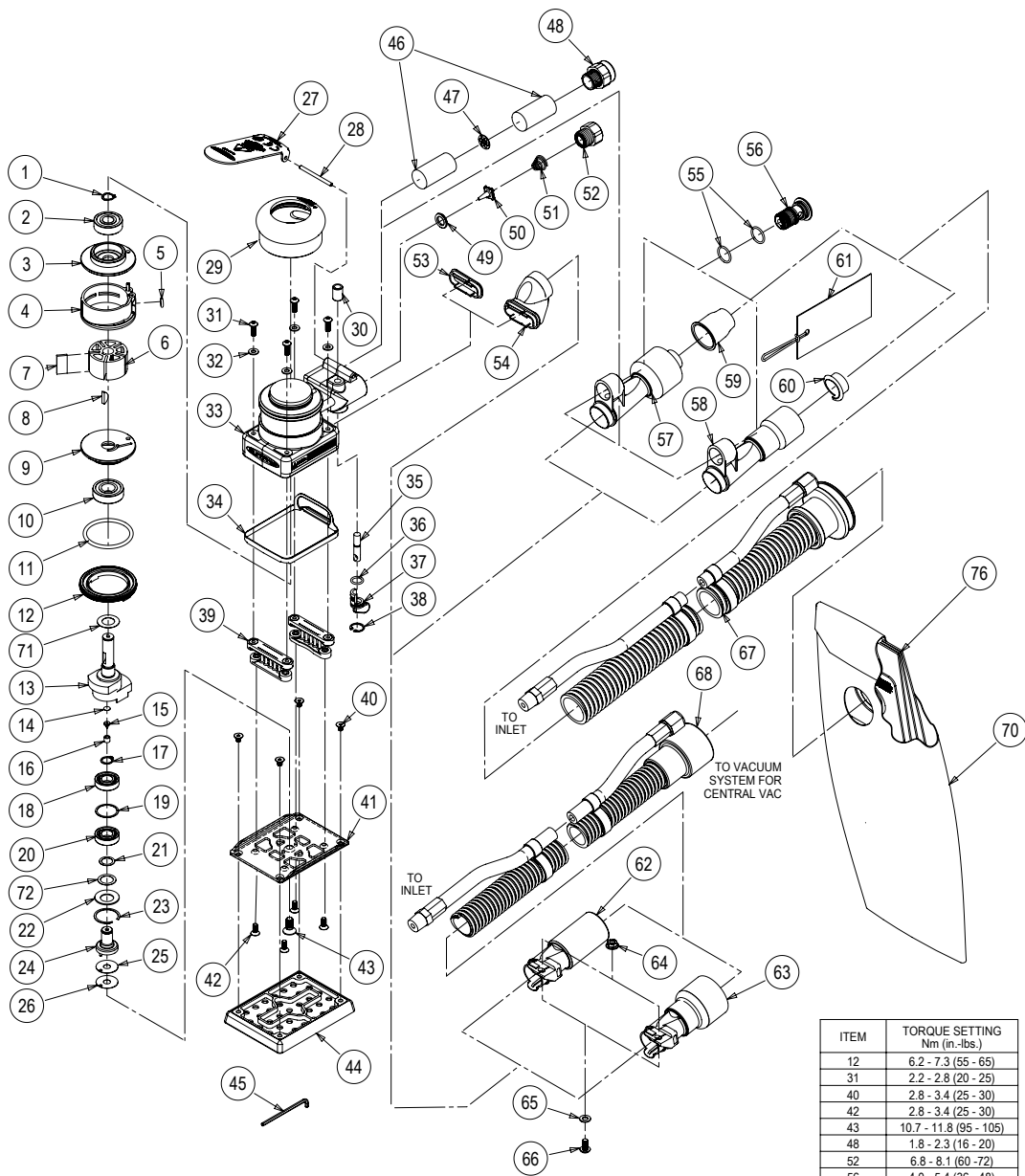

Parts List

Item	Part No.	Description	Qty.
1	SPA0040	RETAINING RING	1
2	SPA0021	BEARING	1
3	SPB0017	REAR ENDPLATE	1
4	SPA0005	CYLINDER ASSEMBLY	1
5	SPA0042	O-RING	1
6	SPB0005	ROTOR	1
7	SPA0010	VANE	5
8	SPA0041	KEY	1
9	SPB0016	FRONT ENDPLATE	1
10	SPA0019	BEARING	1
11	SPA0045	O-RING	1
12	SPA0001	LOCK RING	1
13	SPB0102	SHAFT BALANCER	1
14	SPA0122	FILTER	1
15	SPA0121	VALVE	1
16	SPA0120	RETAINER	1
17	SPA0107	RETAINING RING	1
18	SPA0162	BEARING	1
19	SPA0196	SHIM	1
20	SPA0161	BEARING	1
21	SPA0108	SHIM	1
22	SPA0126	WASHER	1
23	SPA0177	RETAINING RING	1
24	SPA0163	SPINDLE ASSEMBLY	1
25	SPA0080	SPACER	1
26	SPA0079	SPACER	1
27	SPA2873	THROTTLE LEVER FOR 10,000 OPM OS	1
28	SPA0031	SPRING PIN	1
29	SPA0241	2 ½ in. (65 mm) GRIP	1
	SPA0242	2 ¾ in. (69 mm) GRIP	OPT
	SPA0243	3 in. (75 mm) GRIP	OPT
30	SPA0015	VALVE SLEEVE	1
31	SPA0768	SCREW	4
32	SPA0076	WASHER	4
33	SPA2877	HOUSING	1
34	SPC0162	SHROUD SEAL	1
35	SPA0008	VALVE STEM ASSEMBLY	1
36	SPA0043	O-RING	1
37	SPB0014	SPEED CONTROL	1
38	SPA0039	RETAINING RING	1
39	SPC0018	MINI PAD SUPPORT ASSEMBLY	2
40	SPA0766	SCREW	4
41	SPB0101	PAD BACKING	1
42	SPA0767	SCREW	4
43	SPA0078	SCREW	1
44	NA	1 BACK-UP PAD SUPPLIED WITH EACH TOOL (TYPE DETERMINED BY MODEL)	1
45	SPA0864	2.5mm HEX WRENCH	1
46	SPA0032	MUFFLER	2
47	SPA0038	PLATE	1
48	SPA0166	MUFFLER HOUSING	1
49	SPA0009	SEAT	1
50	SPA0007	VALVE	1
51	SPA0014	VALVE SPRING	1
52	SPA0013	INLET BUSHING	1
53	SPB0069	SNAP-IN VACUUM COVER PLATE	1
54	SPC0017	SNAP-IN EXHAUST ADAPTER	1
55	SPA0044	O-RING	2
56	SPA0722	SGV RETAINER	1
57	SPA0410	Ø 1 in. (28 mm) HOSE SuperVAC™ SGV SWIVEL EXHAUST ASSEMBLY	1
58	SPA0409	Ø ¾ in. (19 mm) HOSE SuperVAC™ SGV SWIVEL EXHAUST ASSEMBLY	OPT
59	SPA0778	1 in. (28 mm) HOSE SEAL	1
60	SPA0854	¾ in. (28 mm) HOSE SEAL	OPT
61	SPA0935	1 in. (28 mm) HOSE SEAL TAG WITH INSTRUCTION	1
62	SPA0298	Ø ¾ in. (19 mm) SuperVAC™ CV SWIVEL EXHAUST ASSEMBLY	OPT
63	SPA0092	Ø 1 in. (28 mm) SuperVAC™ CV SWIVEL EXHAUST ASSEMBLY	1
64	SPA0048	NUT	1
65	SPA0047	WASHER	1
66	SPA0769	SCREW	1
67	SPA0412	Ø 1 in. (28 mm) VACUUM HOSE TO Ø 1 in. (28 mm) DOUBLE BAG FITTING AND AIRLINE ASSEMBLY	1
	SPA0411	Ø ¾ in. (19 mm) VACUUM HOSE TO Ø ¾ in. (19 mm) DOUBLE BAG FITTING AND AIRLINE ASSEMBLY	OPT
68	SPA0392	Ø 1 in VAC HOSE TO Ø 1 in /28 mm x Ø 1 1/2 in. ADAPTER COUPLING AND AIRLINE ASSEMBLY	OPT
69	SPC0109	VACUUM BAG INSERT	1
70	SPC0110	VACUUM BAG	1
71	SPA2541	FRONT BEARING DUST SHIELD	1
72	SPA2543	SPINDLE BEARING DUST SHIELD	1

Product Configuration/Specifications: 10,000 OPM 3 x 4 in. (75 x 100mm) Orbital Sander

Note: All Self Generated Vacuum machines use Ø 1 in. Vacuum Hose Fittings Standard. Ø ¾ in. is available.
All Central Vacuum machines use Ø 1 in. Vacuum Hose Fittings Standard. Ø ¾ in. is available.

Orbit	Pad Face	Vacuum Type	Pad Type	Model No.	Product Net Weight Pound (kg)	Height inch (mm)	Length inch (mm)	Power HP (watts)	Air Consumption scfm (LPM)	**Noise Level dBA	**Vibration Level m/s ²	**Uncertainty Factor ²
1/8 in. (3 mm)	Vinyl	Non-Vacuum	Standard	SP341000	1.47 (0.67)	3.3 (84)	5.5 (139)	.24 (179)	16 (453)	73	3.2	1.6
		Central Vacuum	Standard	SP341034	1.58 (0.72)	3.3 (84)	8.0 (202)	.24 (179)	16 (453)	72	3.1	1.5
		Self-Gen. Vacuum	Standard	SP341067	1.63 (0.74)	3.3 (84)	8.2 (209)	.24 (179)	16 (453)	83	3.5	1.8
	Hook	Non-Vacuum	Standard	SP341001	1.47 (0.67)	3.3 (84)	5.5 (139)	.24 (179)	16 (453)	73	3.2	1.6
		Central Vacuum	Standard	SP341035	1.58 (0.72)	3.3 (84)	8.0 (202)	.24 (179)	16 (453)	72	3.1	1.5
		Central Vacuum	Screen Vacuum	SP341036	1.58 (0.72)	3.3 (84)	8.0 (202)	.24 (179)	16 (453)	72	3.1	1.5
		Self-Gen. Vacuum	Standard	SP341068	1.63 (0.74)	3.3 (84)	8.2 (209)	.24 (179)	16 (453)	83	3.5	1.8
		Self-Gen. Vacuum	Screen Vacuum	SP341069	1.63 (0.74)	3.3 (84)	8.2 (209)	.24 (179)	16 (453)	83	3.5	1.8

*The noise test is carried out in accordance with EN ISO 15744:2008: Measurement of noise emission from hand-held non-electric power tools.

**The vibration test is carried out in accordance with EN 28662-1: Hand-held portable power tools – Measurement of vibration at the handle. Part 1: General and EN 8662-8, 1997. Hand-held portable power tools – Measurement of vibration at the handle. Part 8: Polishers and rotary, orbital and random orbital sanders

Specifications subject to change without prior notice.

*The values stated in the table are from laboratory testing in conformity with stated codes and standards and are not sufficient for risk evaluation. Values measured in a particular work place may be higher than the declared values. The actual exposure values and amount of risk or harm experienced to an individual is unique to each situation and depends upon the surrounding environment, the way in which the individual works, the particular material being worked, work station design as well as upon the exposure time and the physical condition of the user. SurfPrep™ cannot be held responsible for the consequences of using declared values instead of actual exposure values for any individual risk assessment.

Further occupational health and safety information can be obtained from the following websites:

<http://europe.osha.eu.int> (Europe)

<http://www.osha.gov> (USA)

Work Stations

The tool is intended to be operated as a hand held tool. It is always recommended that the tool be used when standing on a solid floor. It can be in any position but before any such use, the operator must be in a secure position having a firm grip and footing and be aware that the sander can develop a torque reaction. See the section "Operating Instructions".

Putting the Tool into Service

Use a clean lubricated air supply that will give a measured air pressure at the tool of 90 psig (6.2 bar) when the tool is running with the lever fully depressed. It is recommended to use an approved 3/8 in. (10 mm) x 25 ft (8 m) maximum length airline. It is recommended that the tool be connected to the air supply as shown in Figure 1.

Do not connect the tool to the airline system without incorporating an easy to reach and operate air shut off valve. The air supply should be lubricated. It is strongly recommended that an air filter, regulator and lubricator (FRL) be used as shown in Figure 1 as this will supply clean, lubricated air at the correct pressure to the tool. Details of such equipment can be obtained from your supplier. If such equipment is not used then the tool should be manually lubricated.

To manually lubricate the tool, disconnect the airline and put 2 to 3 drops of suitable pneumatic motor lubricating oil such as Fuji Kosan FK-20, Mobil ALMO 525 or Shell TORCULA® 32 into the hose end (inlet) of the machine. Reconnect tool to the air supply and run tool slowly for a few seconds to allow air to circulate the oil. If the tool is used frequently, lubricate it on a daily basis or lubricate it if the tool starts to slow or lose power.

It is recommended that the air pressure at the tool be 90 PSI (6.2 Bar) while the tool is running so the maximum RPM is not exceeded. The tool can be run at lower pressures but should never be run higher than 90 PSI (6.2 Bar). If run at lower pressure the performance of the tool is reduced.

Operating Instructions

- 1) Read all instructions before using this tool. All operators must be fully trained in its use and aware of these safety rules. All service and repair must be carried out by trained personnel.
- 2) Make sure the tool is disconnected from the air supply. Select a suitable abrasive and secure it to the back-up pad. Be careful and center the abrasive on the back-up pad.
- 3) Always wear required safety equipment when using this tool.
- 4) When sanding always place the tool on the work then start the tool. Always remove the tool from the work before stopping. This will prevent gouging of the work due to excess speed of the abrasive.
- 5) Always remove the air supply to the sander before fitting, adjusting or removing the abrasive or back-up pad.
- 6) Always adopt a firm footing and/or position and be aware of torque reaction developed by the sander.
- 7) Use only correct spare parts.
- 8) Always ensure that the material to be sanded is firmly fixed to prevent its movement.
- 9) Check hose and fittings regularly for wear. Do not carry the tool by its hose; always be careful to prevent the tool from being started when carrying the tool with the air supply connected.

- 10) Dust can be highly combustible. Vacuum dust collection bag should be cleaned or replaced daily. Cleaning or replacing of bag also assures optimum performance.
- 11) Do not exceed maximum recommended air pressure. Use safety equipment as recommended.
- 12) The tool is not electrically insulated. Do not use where there is a possibility of coming into contact with live electricity, gas pipes, water pipes, etc. Check the area of operation before operation.
- 13) Take care to avoid entanglement with the moving parts of the tool with clothing, ties, hair, cleaning rags, etc. If entangled, it will cause the body to be pulled towards the work and moving parts of the machine and can be very dangerous.
- 14) Keep hands clear of the spinning pad during use.
- 15) If the tool appears to malfunction, remove from use immediately and arrange for service and repair.
- 16) Do not allow the tool to free speed without taking precautions to protect any persons or objects from the loss of the abrasive or pad.

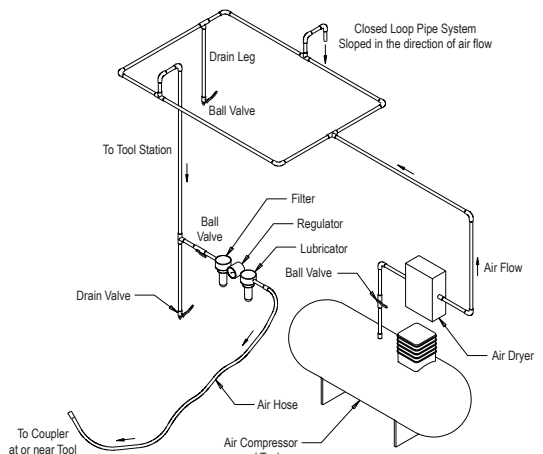

Figure 1



SERVICE INSTRUCTIONS FOR 10,000 OPM 3 x 4 in. (75 x 100 mm) ORBITAL SANDERS

Service Tools and Accessories

When an SurfPrep™ Low Profile Orbital Sander needs to be serviced, we offer tool kits to make the disassembly/assembly fast and easy. The Service Tools are highly recommended for use with the Overhaul Service Kit. The Universal Tool Kit will work with all current models. NOTICE: To receive any expressed or implied warranty, the tool must be repaired by an authorized SurfPrep™ Service Center. The 3 in. x 4 in. Orbital Sander Service Instructions section provided below is for use after completion of the warranty period.

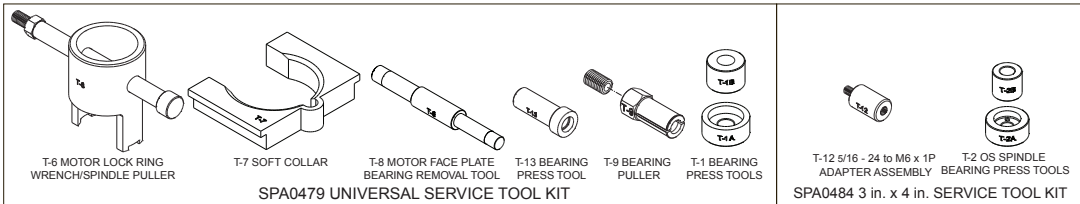

Overhaul Service Kit

The SPA0311 Overhaul Service Kit contains all the replacement parts that naturally wear over time and a straightforward manual to make servicing an SurfPrep™ sander simple. Overhauling the Orbital Sander can be made even easier with the use of the above Service Tools. The Service Tools also reduce the chance of improper assembly.

Overhaul Service Kit for 10,000 OPM 3x4 in. OS Contents		
Part No.	Description	Qty.
SPA0040	External Retaining Ring	1
SPA0021	Bearing	1
SPA0042	O-Ring	1
SPB0005	Rotor	1
SPA0010	Vane	5
SPA0041	Key	1
SPA0019	Bearing	1
SPA0162	Bearing	1
SPA0196	Shim	1
SPA0161	Bearing	1
SPA0008	Valve Stem Assembly	1
SPA0043	O-Ring	1
SPA0039	Internal Retaining Ring	1
SPC0018	Mini Pad Support Assembly	2
SPA0032	Muffler	2
SPA0166	Muffler Housing	1
SPA0009	Seat	1
SPA0007	Valve	1
SPA0014	Valve Spring	1

Sander Spare Parts Kits

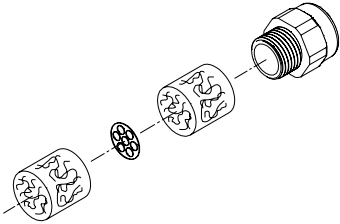

10,000 RPM Muffler Kit
Reorder P/N SPA0095

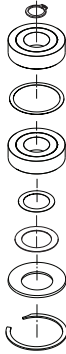

OS Spindle Bearing Kit
Reorder P/N SPA0497

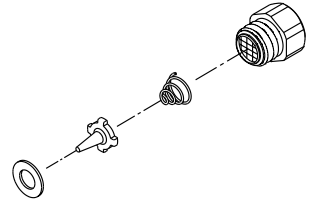

1/4-18 NPT Air Inlet Kit
Reorder P/N SPA0431

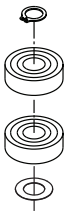

Endplate Bearing Kit
Reorder P/N SPA0434

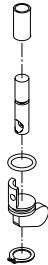

Speed Valve Kit
Reorder P/N SPA0432

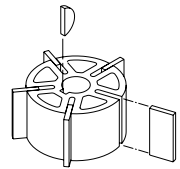

Rotor, Vanes and Key Kit
Reorder P/N SPA0063

3 in. x 4 in. (75 x 100 mm) Orbital Sanders Service Instructions

NOTICE: To receive any expressed or implied warranty, the tool must be repaired by an authorized Service Center. The 3 in. x 4 in. Orbital Sander Service Instructions section provided is for use after completion of the warranty period.

DISASSEMBLY INSTRUCTIONS

Changing Grips:

1. The Grip has two "tabs" that wrap around the body of the sander under the inlet and exhaust. With a small screwdriver pick out one of the "tabs" of the Grip, and then continue to go underneath the grip with the screwdriver and pry the Grip off the sander. To install a new Grip, hold the Grip by the tabs making them face outward, align the Grip and slide it under the Throttle Lever then press the Grip down until it seats onto the top of the sander. Make sure the two "tabs" seat under the inlet and exhaust.

Motor Disassembly:

1. Remove the Pad from the machine by removing the four Screws. Lightly secure tool in a vise using the T-7 Soft Collar or padded jaws with the bottom of the machine facing upward. Remove the four Screws and then the Screw. Remove the Pad Backing but be careful to observe and collect the optional Spacer(s) found between the Spindle Assembly and the Pad Backing.
2. Take the machine out of the vise and take off the Soft Collar. Remove the four Screws with the Washers from the Housing and remove the Mini Pad Supports. Lightly re-secure the tool in a vise using the T-7 Soft Collar or padded jaws with the Lock Ring facing upward.
3. Remove the Lock Ring with the T-6 Motor Lock Ring Wrench/ Spindle Puller Tool. Remove the O-Ring from the Lock Ring and set it aside. The motor assembly can now be lifted out of the Housing.
4. Remove the Retaining Ring from the groove in the Shaft Balancer and the O-Ring from the Cylinder.
5. Remove the Rear Endplate. This may require setting the Rear Endplate on a Bearing Separator and lightly pressing the shaft through the Bearing and Rear Endplate. Remove the Cylinder and the Rotor with the five Vanes from the Shaft Balancer. Remove the Key then press off the Front Endplate with the Bearing. It may be necessary to remove the Bearing with a Bearing Separator if it came out of the Front Endplate and stuck to the shaft of the Shaft Balancer.
6. Remove and discard Dust Shield from the Shaft Balancer.
7. Remove the Bearing(s) from the Endplates by using the T-8 Bearing Removal Tool to press out the Bearings.

Shaft Balancer and Spindle Disassembly:

1. Grip the shaft end of the Shaft Balancer in a padded vise. With a thin screwdriver pick out the slotted end of the Retaining Ring and peel out.
2. Screw the female end of the T-12 5/16-24 to M6 x 1P Adapter into the male end of the T-6 Motor Lock Ring Wrench/Spindle Puller Tool. Screw the Service Wrench Assembly into the Spindle Assembly until hand tight. Apply a gentle heat from a propane torch or hot air gun to the large end of the Shaft Balancer shaft until it is about 100° C (212° F) to soften the adhesive. Do not over heat. Remove the Spindle Assembly by using the slider to give sharp outward blows to the Spindle. Allow the Spindle and Shaft Balancer to cool.
3. Remove the Retaining Ring from the Spindle Assembly. Use a Bearing Separator to remove the Bearing, Shim, Bearing, Shim, Dust Shield and the Washer from the Spindle Assembly. Discard Dust Shield.
4. The AirSHIELD™ components are held in place by the light press fit of the Retainer. These components can be damaged during removal and may need to be replaced if removed. To remove the Retainer, use an O-ring pick or a #8 sheet metal screw to grip and pull out the Retainer. Remove the Valve and Filter from the bore in the Shaft Balancer. If the Retainer and Valve were not damaged, they can be reused. However, the filter should be replaced on re-assembly.

Housing Disassembly:

1. For Non-Vacuum (NV) and Central Vacuum (CV) machines follow steps A – C below (unless otherwise noted). For Self Generated Vacuum (SGV) machines disregard steps A – F and move onto Step G below.
 - A. Unscrew the Muffler Housing from the Housing.
 - B. Remove the Muffler from the cavity of the Muffler Housing.
 - C. Remove the Plate and second Muffler from the exhaust port of the Housing.
- For Central Vacuum (CV) Exhaust machines:**
 - D. Remove the Screw, Washer and Nut.
 - E. Press downward on the swivel end of the Ø 1 in. (28 mm) SuperVAC™ CV Swivel Exhaust Assembly or the Ø ¾ in. (19 mm) SuperVAC™ CV Swivel Exhaust Assembly releasing the tab on the end of the exhaust assembly from the Snap-In Exhaust Adapter.
 - F. Work off the Snap-In Exhaust Adapter. Move on to step 2.

For Self Generated Vacuum (SGV) Exhaust machines:

- G. Unscrew the SGV Retainer Assembly with an 8 mm hex key. Remove the two O-rings. Take off the Ø 1 in. (28 mm) SGV Swivel Exhaust Assembly or the Ø ¾ in. (19 mm) Hose SGV Swivel Exhaust Assembly.
- H. Work off the Snap-In Exhaust Adapter.
2. Place the Speed Control to the midway position and remove the Retaining Ring. The Speed Control will now pull straight out. Remove the O-Ring.
3. Unscrew the Inlet Bushing Assembly from the Housing. Remove the Valve Spring, Valve, Valve Seat, Valve Stem with the O-Ring. Press out the Spring Pin from the Housing and remove the Lever.

ASSEMBLY INSTRUCTIONS

NOTE: All assembly must be done with clean dry parts and all bearings are to be pressed in place by the correct tools and procedures as outlined by the bearing manufacturers.

Housing Assembly:

1. Install the Throttle Lever into Housing with the Pin.
2. Lightly grease O-Ring and place it on Speed Control. Install Valve Stem, O-Ring (cleaned and lightly greased) and insert the Speed Control into Housing in the midway position. Install Retaining Ring.

CAUTION: Make sure the Retaining Ring is completely snapped into groove in the Housing.

3. Install the Valve Seat, the Valve and Valve Spring. Coat the threads of the Bushing Assembly with 1 or 2 drops of Loctite™ 222 or equivalent non-permanent pipe thread sealant. Screw the assembly into the Housing. See the "Parts Page" for torque settings. Place a clean Muffler and Plate into the exhaust port of the Housing. Be careful not to lose the Plate and Muffler out of the exhaust before it is secured in one of the following steps.

NOTE: If the machine is a CV/SGV model proceed with the appropriate vacuum exhaust assembly instructions, otherwise move onto step 4.

For CV (Central Vacuum) Exhaust machines:

- A. Attach the Snap-In Exhaust Adapter.
- B. Take the Ø 1 in. (28 mm) SuperVAC™ CV Swivel Exhaust Assembly or the Ø ¾ in. (19 mm) SuperVAC™ CV Swivel Exhaust Assembly and put the "tongue" on the male end of it into the female end of the Snap-In Exhaust Adapter. With the swivel end of the SuperVAC™ Exhaust angled towards the ground work the "tongue" and male end into the female end of the Snap-In Exhaust Adapter by rotating the swivel end up and in at the same time until it seats.
- C. Thread the Screw into the mounting hole of the Ø 1 in. (28 mm) SuperVAC™ CV Swivel Exhaust Assembly or the Ø ¾ in.

in. (19 mm) SuperVAC™ CV Swivel Exhaust Assembly and Housing until the end of it is flush with the inside surface of the Housing. Place the washer and Nut into the cavity of the Housing and thread the Screw into them until tight. Move onto step 4.

For SGV (Self Generated Vacuum) Exhaust machines:

- A. Attach the Snap-In Exhaust Adapter.
- B. Lightly grease two O-rings and place them over the two grooves in the SGV Retainer Assembly. Slide the SGV Retainer Assembly into the bore of the Ø 1 in. (28 mm) SGV Swivel Exhaust Assembly or the Ø ¾ in. (19 mm) Hose SGV Swivel Exhaust Assembly.
- C. Attach the SGV Swivel Exhaust Assembly to the exhaust port of the Housing by means of the SGV Retainer Assembly and by taking the male end of the SGV Swivel Exhaust Assembly and placing it into the female end of the Snap-In Exhaust Adapter. Screw the SGV Retainer Assembly into the threaded exhaust port on the Housing with an 8 mm hex key. See the "Parts Page" for torque settings. Move onto the section "Spindle, AirSHIELD™ and Balancer Shaft Assembly".
4. Place a clean Muffler in the Muffler Housing and screw the Muffler Housing into the exhaust port of the Housing. See the "Parts Page" for torque settings.

Spindle, AirSHIELD™ and Balancer Shaft Assembly:

1. Place the T-2A Spindle Bearing Pressing Tool Base onto a flat, clean surface of a small hand press or equivalent with the spindle pocket facing upward. Place the Spindle into the spindle pocket with the shaft facing upward.
2. Place the Washer on the Spindle shaft with the curve of washer facing out so that the outside diameter of the washer will contact the outer diameter of the Bearing. Place the Dust Shield onto the Spindle shaft. Lay the Shim on the shoulder of the Spindle. Note: Be sure that the Dust Shield is past the shoulder where Spacer rests. Place the Bearing (one seal) on the Spindle with the seal side toward the Washer. NOTE: Make sure that both the inner and outer races of the Bearings are supported by the Bearing Press Tool when pressing them into place. Press the Bearing onto the shoulder of Spindle using the T-2B Spindle Bearing Pressing Tool Top as shown in Figure 3.
3. Place the Shim over the Spindle shaft and onto the face of the Bearing making sure it is on center. Press the (no seals/shields) Bearing down using the T-2B Spindle Bearing Pressing Tool Top, being careful to make sure the Shim is still centered on the vertical axis of the Spindle shaft and Bearing. See Figure 4. When the Spindle Assembly is done correctly, the Bearings will rotate freely but not loosely and the Shim

- can be moved but will not slide or move by gravity.
4. Snap the Retaining Ring (not shown in Figure 3 or 4) onto the Spindle Assembly making sure it is completely snapped into the groove.
5. Take the Filter and center it on the small bore that the original Filter was in before removal. With a small diameter screw-driver or flat-ended rod, press the Filter into the bore until it is flat in the bottom of the bore. Place the Valve into the bore so it is oriented correctly, then press the Retainer into the bore until it is flush with the bottom of the Bearing bore.
6. Apply a pin head size drop of #271 Loctite® or equivalent to the outside diameter of each of the bearings on the spindle assembly. Spread the drop of bearing locker around the bearings until distributed evenly. CAUTION: Only a very small amount of bearing locker is needed to prevent rotation of the bearing OD. Any excess will make future removal difficult. Place the Spindle Assembly into the bore of the Shaft Balancer and secure with the Retaining Ring. CAUTION: Make sure that the Retaining Ring is completely snapped into the groove in the Balancer shaft. Allow the adhesive to cure.

Motor Assembly:

1. Place the Dust Shield onto the shaft of the Shaft Balancer.
2. Use the larger end of the T-13 Bearing Press Sleeve to Press the front Bearing (with 2 Shields) onto the shaft of the Shaft Balancer.
3. Slide the Front Endplate with the bearing pocket facing down onto the Motor Shaft. Gently press the Front Endplate onto the front Bearing using the larger end of the T-13 Bearing Press Sleeve until the front Bearing is seated in the bearing pocket of the Front Endplate. CAUTION: Only press just enough to seat the Bearing into the pocket. Over-pressing can damage the Bearing.
4. Place the Key into the groove on the Shaft Balancer. Place the Rotor on the Shaft Balancer, making sure that it is a tight slip fit.
5. Oil the Vanes with a quality pneumatic tool oil and place them in the slots in the Rotor. Place the Cylinder Assembly over the Rotor with the short end of the Spring Pin engaging the blind hole in the Front Endplate. NOTE: The Spring Pin must project .060 in. (1.5 mm) above the flanged side of the Cylinder.
6. Press fit the rear Bearing (2 shields) into the Rear Endplate with the T-1B Bearing Press Tool Top. Make sure the T-1B Press Tool is centered on the O.D. of the outer race. Lightly press fit the Rear Endplate and Bearing over the Shaft Balancer using the small end of the T-13 Bearing Press Sleeve. The sleeve should press only the inner race of the bearing. IMPORTANT: The Rear Endplate and Bearing is

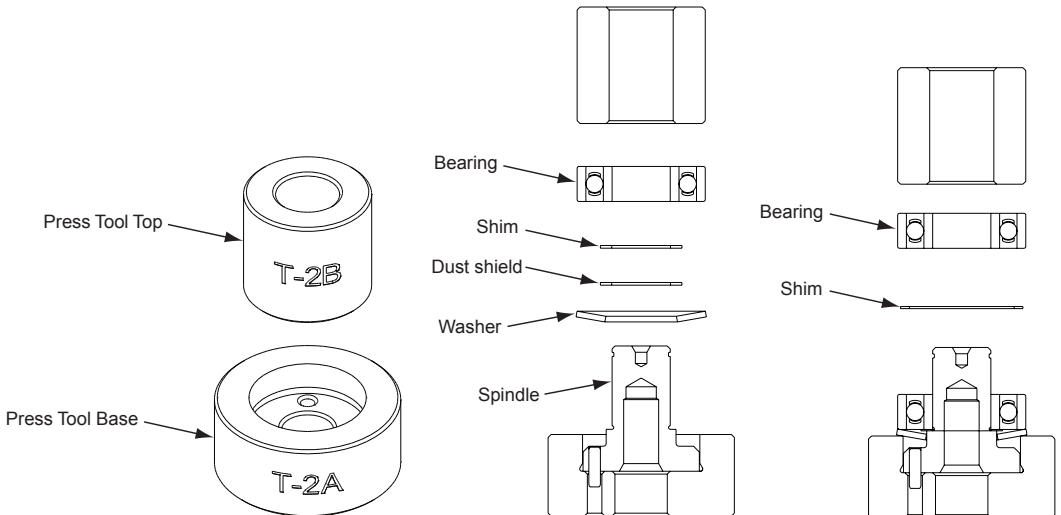

pressed correctly when the Cylinder is squeezed just enough between the Endplates to stop it from moving freely under its own weight when the shaft is held horizontal, but be able to slide between the Endplates with a very light force. If the assembly is pressed too tightly the motor will not run freely. If the pressed assembly is too loose, the motor will not turn freely after assembly in the Housing. CAUTION: If the Rear Endplate assembly is "over-pressed" damage to the Front and Rear Endplate Bearings may result.

7. Secure the assembly by placing the Retaining Ring in the groove of the Shaft Balancer. CAUTION: The Retaining Ring must be placed so that the middle and two ends of the hoop touch the Bearing first. Both raised center portions must be securely "snapped" into the groove in the Shaft Balancer by pushing on the curved portions with a small screwdriver.
8. Lightly grease the O-Ring and place in the air inlet of the Cylinder Assembly.
9. Lightly grease or oil the inside diameter of the Housing, line up the Spring Pin with the marking on the Housing and slide the Motor Assembly into the Housing. Make sure the Pin engages the pocket in Housing.
10. Carefully screw the Lock Ring into the Housing with the T-6 Motor Lock Ring Wrench/Spindle Puller Tool. See the "Parts Page" for torque settings. NOTE: A simple technique to assure first thread engagement is to turn the lock ring counter clockwise with the T-6 Motor Lock Ring Wrench/Spindle Puller while applying light pressure. You will hear and feel a click when the lead thread of the lock ring drops into the lead thread of the housing.
11. Place one of the Mini Pad Support Assemblies into the Housing with the 45 degree chamfer of the base facing outward away from the center of the machine and the arc in the base of the pad support facing toward the center of the machine. Screw tight with the two Screws and Washers. Repeat for second pad support.
12. Using a straight edge placed across both bottom surfaces of the Mini Pad Support Assemblies, measure the distance from the surface of the Spindle Assembly to the straight edge. There should be approximately .010 in. (0.25 mm) of space, if not add supplied Spacers in the combination that most closely results in .010 in. (0.25 mm) of spacing. NOTE: Spindle face must be slightly below Mini Pad Supports for best function. Do not over shim. Apply a small amount of anti-seize compound in the 5-90° c/sink holes of the Pad Backing before assembly. Place the Pad Backing by orientating the Shims with the screw holes and placing the pad backing down onto the Spindle Assembly making sure the Pin goes through the Pad Backing. Add the Screw first and tighten firmly. In a circular rotation apply smaller Screws into the Pad Backing and Mini Pad Support Assemblies but leave them slightly loose until all are in place, and then tighten firmly.
13. Attach a new Pad on the Pad Backing with the four Screws.

Testing:

Place 3 drops of quality pneumatic air tool oil directly into the motor inlet and connect it to a 90 psig (6.2 Bar) air supply. The tool should run between 9,500 and 10,500 Orbits per Minute when the air pressure is 90 psig (6.2 Bar) at the inlet of the tool while the tool is running at free speed.

* Loctite® is a registered trademark of the Loctite Corp.

Troubleshooting Guide

Symptom	Possible Cause	Solution
Low Power and/or Low Free Speed	Insufficient Air Pressure	Check air line pressure at the Inlet of the Sander while the tool is running at free speed. It must be 6.2 Bar (90 psig/620 kPa).
	Blocked Muffler(s)	See the "Housing Disassembly" section for Muffler removal. Replace Muffler Insert (See the "Housing Assembly" Section)..
	Plugged Inlet Screen	Clean the Inlet Screen with a clean, suitable cleaning solution. If Screen does not come clean replace it.
	Worn or Broken Vanes	Install a complete set of new Vanes (all vanes must be replaced for proper operation). Coat all vanes with quality pneumatic tool oil. See "Motor Disassembly" and "Motor Assembly".
	Internal air leakage in the Motor Housing indicated by higher than normal air consumption and lower than normal speed.	Check for proper Motor alignment and Lock Ring engagement. Check for damaged O-Ring in Lock Ring groove. Remove Motor Assembly and Re-Install the Motor Assembly. See "Motor Disassembly" and "Motor Assembly".
	Motor Parts Worn	Overhaul Motor. Contact authorized SurfPrep™ Service Center.
	Worn or broken Spindle Bearings	Replace the worn or broken Bearings. See "Shaft Balancer and Spindle Disassembly" and "Spindle Bearings, AirSHIELD™ and Shaft Balancer Assembly".
Air leakage through the Speed Control and/or Valve Stem.	Dirty, broken or bent Valve Spring, Valve or Valve Seat.	Disassemble, inspect and replace wore or damaged parts. See Steps 2 and 3 in "Housing Disassembly" and Steps 2 and 3 in "Housing Assembly".
Vibration/Rough Operation	Incorrect Pad	Only use Pad Sizes and Weights designed for the machine.
	Addition of interface pad or other material	Only use abrasive and/or interface designed for the machine. Do not attach anything to the Sanders Pad face that was not specifically designed to be used with the Pad and Sander.
	Improper lubrication or buildup of foreign debris.	Disassemble the Sander and clean in a suitable cleaning solution. Assemble the Sander. (See "Service Manual")
	Worn or broken Rear or Front Motor Bearing(s)	Replace the worn or broken Bearings. See "Motor Disassembly" and "Motor Assembly".
	For central vacuum machines it is possible to have too much vacuum while sanding on a flat surface causing the pad to stick to the sanding surface.	For CV machines reduce vacuum through the vacuum system.



SurfPrep™ Tools
571 BIRCH STREET LAKE ELSINORE, CA 92530
Tel : 951-245-4200
Fax: 951-245-4299